



# 4x4 RANGE

Cab/Chassis specification as at January 1999.  
RGS/IGM2746

## MODEL RANGE SUMMARY

Model	FSS 550 4x4	FSS 550 Crew	FTS 750 4x4	FTS 750 Crew
GVM	10,000kg		13,000kg	
GCM	15,000kg		18,000kg (off-road) / 20,500kg (on-road)	
Engine type	Isuzu SITEC 200		Isuzu SITEC 200	
Displacement	8226cc		8226cc	
Power	150kw @ 2850rpm (ISO 1585)		150kw @ 2850rpm (ISO 1585)	
Torque	539Nm @ 1700rpm (ISO 1585)		539Nm @ 1700rpm (ISO 1585)	
Transmission	5 Speed direct drive		6 Speed direct drive	
Front Axle Capacity	3,900kg		4,700kg	
Rear Axle Capacity	6,500kg		9,200kg	

## CABIN SPECIFICATIONS AND APPOINTMENTS

### CAB EXTERIOR

- All steel cab with welded strengthening ribs and side door impact beams. Torsion bar assisted cabin tilt to 45° (standard cabs). Electro-hydraulic tilt mechanism (crew cab models).
- Four point cabin suspension utilising silicone filled rubber isolators (standard cab only).
- Cation electrodeposition primer.
- Heavy duty bumper bar with step holes and footplate.
- Halogen headlamps, hinged for easy bulb replacement.
- Park lamps and cabin clearance lamps.
- Turn signal lamps in front bumper and on cab sides.
- 2 speed windscreen wiper / washer system with variable intermittent mode. Triple washer jets mounted on wiper arms.
- Tinted and laminated windscreen. Tinted and toughened side and rear glass.
- 'West Coast' type rear view mirrors.
- Alloy, non-slip cabin entry steps. Steel rear entry steps (crew cab).
- Lift-up front panel for access to clutch and windscreen washer fluids without tilting the cabin. Engine fluid check points at rear of cabin.

### CAB INTERIOR

- Fully trimmed cab interior with cloth seat facings, formed roof lining. Overhead storage lockers. Driver and passenger sun visors.
- Pull out drinks holder in centre fascia, cigarette lighter with ash trays in doors.

- Isringhausen ISRI 6500/517 air suspension driver's seat with auto weight adjustment to 130kg. Height, rake and back rest recline adjustment. Pneumatic lumbar support.
- Outboard reclining passenger seat with under seat storage drawer. Folding centre seat back with lockable compartment and tray.
- Rear 4 person bench seat with vinyl seat covering (crew cab only).
- All outboard seating positions have lap/sash seat belts with emergency locking retractors. All inner seating positions have lap seat belts.
- Tilt/telescopic adjustable steering column with single release lever. Soft feel urethane steering wheel with zero offset to driver's seat.
- Easy entry grab handles on 'A' and 'B' pillars and 'B' and 'C' pillars for rear door (crew cab).
- Heater demister with 4 speed fan, 4 outlet vents to screen, 5 fascia outlets, 5 foot outlets, demister ducts to door glass.
- Optional fully integrated air conditioning.
- Eurovox AM/FM radio cassette with digital clock, dash mounted. Remote seek/volume and mute switch located on dash to right of steering wheel.
- DIN standard aperture in dash for CB radio.
- 12 Volt /100W cigarette lighter type electrical socket located in centre console.
- 24 Volt - 2 pin accessory plug in centre console.
- Park brake activation lever at left side of driver's seat.
- Combination passenger-side dash storage tray/fuse panel cover.
- Interior rear vision mirror.
- Passenger side assist grip.
- Driver's left foot rest.

- Full cab width grab rail for rear passengers (crew cab models).
- Exhaust vents rear/upper cab.
- Business card clip. Coat hook at rear of cab.
- Elastic mesh pocket on driver's door.

### CONTROLS

- Left side combination stalk switch for exhaust brake, windscreen wipers and washer, hazard lamps.
- Right side combination stalk switch for headlamps, high beam and turn signals.
- Engine idle speed adjust control.
- Key operation for engine start and stop, external engine crank switch for service when cab is tilted.
- 3 way switch for interior lamp activated by driver and passenger front doors.

### INSTRUMENTATION

- GAUGES: Speedometer, odometer, trip meter and tachometer. Gauges for coolant temperature, fuel level and brake air pressure.
- WARNING LAMPS: With warning bulb check switch. Battery charge, oil pressure, low air pressure, brake system, stop and tail light failure.
- INDICATOR LAMPS: Turn signals, parking brake on, high beam on, exhaust brake engaged. Reversing lamp and beeper.

### TOOLS

- Lockable tool box. 10,000kg capacity jack and wheel changing tools, tool kit.

## FSS 550 4x4 & FSS 550 Crew

### DRIVELINE SPECIFICATIONS

#### ENGINE: ISUZU SITEC 200

Isuzu 6HHI - S, 6 cylinder overhead camshaft, four stroke, direct injection, diesel.

**Bore x Stroke:** 115mm x 132mm

**Displacement:** 8226cc

**Compression Ratio:** 18.5 : 1

**Power:** 150kW @ 2850 RPM (ISO 1585)

**Torque:** 539Nm @ 1700 RPM (ISO 1585)

#### COOLING SYSTEM

- 6 blade plastic cooling fan 500mm diameter with thermatic fan clutch.
- Corrugated fin radiator with fan shroud. Frontal area 3820cm<sup>2</sup>. Coolant capacity 23.3 litres.

#### AIR INTAKE

- Donaldson 11" two stage with vertical air intake stack and rain head.

#### EXHAUST

- Horizontal exhaust muffler with vertical exhaust stack.
- Exhaust brake, air controlled.

#### FUEL SYSTEM

- In line plunger, Bosch 'ADS' type fuel injection pump with mechanical all speed governor. In line filter, see through water separator with drain cock.
- Single fuel tank, capacity 180 litres.

#### CLUTCH

- Hydraulic control dry single plate. 355mm (14") diameter.
- Asbestos free lining material. Total lining area (both sides) 1164cm<sup>2</sup>.

#### TRANSMISSION

ISUZU MBJ5J, 5 speed direct drive, constant mesh with synchromesh on gears 2-5.

Oil capacity 4.4 litres.

- Gear ratios: (: 1)

1st	2nd	3rd	4th	5th	Rev
6.378	3.627	2.307	1.452	1.000	6.595

- Maximum geared speed 98km/h.

- Two speed transfer case, electric/air shift control, oil to oil cooler.

- Ratios (: 1) High 1.000, Low 2.091.

Oil capacity 3.0 litres.

#### FRONT AXLE

ISUZU FD039 CAPACITY 3900KG

- Split type, fully floating with Birfield type steering ball joint. Ratio: 5.125:1.
- Spiral bevel type ring gear, 365mm diameter. Oil capacity 3.2 litres.

#### REAR AXLE

ISUZU R065 CAPACITY 6500KG

- Banjo type, fully floating, No-Spin differential lock. Ratio: 5.125: 1.
- Hypoid type ring gear, 365mm diameter. Oil capacity 6.5 litres.

### CHASSIS SPECIFICATIONS

#### CHASSIS FRAME

- Parallel rail, ladder type channel section, cold riveted.
- Straight frame for easy body mounting. Frame width 840mm.
- Side member dimensions: 229mm x 71mm x 8mm.
- Material, SAPH440, weldable mild steel.

#### SUSPENSION

- Semi-elliptical, alloy steel tapered multi-leaf springs. Fully wrapped eye with greaseable shackles.

##### FRONT

1350mm x 70mm x 12mm x 2 leaves.  
x 70mm x 14mm x 2 leaves.  
x 70mm x 16mm x 1 leaf.

- Hydraulic, double acting, telescopic shock absorbers.

##### REAR

Main: 1300mm x 70mm x 11mm x 3 leaves.  
x 70mm x 12mm x 4 leaves.

Aux: 850mm x 70mm x 10mm x 3 leaves.  
x 70mm x 11mm x 4 leaves

#### BRAKES

- Air over hydraulic, dual circuit, front two leading, rear dual two leading. Drum diameter front 400mm, rear 410mm. Total swept area 5,853cm<sup>2</sup>.
- Air dryer.
- All steel tubing.
- Asbestos free lining material.
- Spring park brake acting on rear wheels.

#### STEERING

- Fully integral, power assisted, recirculating ball type.
- Gear ratio 16.1 ~18.8 : 1. Turns lock to lock 2.8.
- Gear driven vane type oil pump. Oil capacity 1.5 litres.

#### WHEELS AND TYRES

##### WHEELS:

- 6.50T x 20, 8 stud disc wheels.
- Number of wheels and tyres 7, including spare. Winch type spare wheel carrier.

##### TYRES:

8.25R20 133/131K Tubed Type radial ply tyres front and rear.

Type: Michelin XZY

Load & Speed Ratings per tyre:

2060kg (Single) / 1950kg (Dual) / 110km/h.

#### ELECTRICAL SYSTEM

- Batteries - 2 x 12 volt / 65 amp/h, negative earth.
- Alternator - 24 volt / 40 amp.
- Starter motor - 24 volt / 4.5kW.
- Rear stop and tail lamps and licence plate lamp with long leads for variable body mounting.

# 4x4 Range

## FTS 750 4x4 & FTS 750 Crew

### ENGINE: ISUZU SITEC 200

Isuzu 6HHI - S, 6 cylinder overhead camshaft, four stroke, direct injection, diesel.

**Bore x Stroke:** 115mm x 132mm

**Displacement:** 8226cc

**Compression Ratio:** 18.5 : 1

**Power:** 150kW @ 2850 RPM (ISO 1585)

**Torque:** 539Nm @ 1700 RPM (ISO 1585)

### COOLING SYSTEM

- 6 blade plastic cooling fan 500mm diameter with thermatic fan clutch.
- Corrugated fin radiator with fan shroud. Frontal area 3820cm<sup>2</sup>. Coolant capacity 23.3 litres.

### AIR INTAKE

- Donaldson 11" two stage with vertical air intake stack and rain head.

### EXHAUST

- Horizontal exhaust muffler with vertical exhaust stack.
- Exhaust brake, air controlled.

### FUEL SYSTEM

- In line plunger, Bosch 'ADS' type fuel injection pump with mechanical all speed governor. In line filter, see through water separator with drain cock.
- Single fuel tank, capacity 180 litres.

### CLUTCH

- Hydraulic control dry single plate. 355mm (14") diameter.
- Asbestos free lining material. Total lining area (both sides) 1164cm<sup>2</sup>.

### TRANSMISSION

ISUZU MLD6D, 6 speed direct drive, constant mesh with synchromesh on gears 2-6.

Oil capacity 6.5 litres.

- Pneumatic gearshift assistance.

- Gear ratios: (: 1)

1st	2nd	3rd	4th	5th	6th	Rev
7.166	4.526	2.919	1.954	1.254	1.000	7.276

- Maximum geared speed 96km/h.

- Two speed transfer case, electric/air shift control, oil to oil cooler.

- Ratios (: 1) High 1.000, Low 2.091.

Oil capacity 3.0 litres.

### FRONT AXLE

ISUZU FD047 CAPACITY 4700KG

- Split type, fully floating with Birfield type steering ball joint. Ratio: 5.571:1.

- Spiral bevel type ring gear, 365mm diameter. Oil capacity 5.5 litres.

### REAR AXLE

ISUZU R092 CAPACITY 9200KG

- Banjo type, fully floating, No-Spin differential lock. Ratio: 5.571:1.

- Hypoid type ring gear, 398mm diameter.

Oil capacity 8.0 litres.

### CHASSIS FRAME

- Parallel rail, ladder type channel section, cold riveted.
- Straight frame for easy body mounting. Frame width 850mm.
- Side member dimensions: 240mm x 72.5mm x 4.5mm.
- Material, HT540A, weldable high tensile steel.

### SUSPENSION

- Semi-elliptical, alloy steel tapered multi-leaf springs. Fully wrapped eye with greaseable shackles.

#### FRONT

1470mm x 80mm x 12mm x 3 leaves.  
x 80mm x 13mm x 5 leaves.  
x 80mm x 18mm x 1 leaf.

- Hydraulic, double acting, telescopic shock absorbers.

#### REAR

Main: 1420mm x 80mm x 12mm x 1 leaf.  
x 80mm x 13mm x 6 leaves.  
Aux: 1000mm x 80mm x 12mm x 9 leaves.

### BRAKES

- Air over hydraulic, dual circuit, front two leading, rear dual two leading. Drum diameter front 400mm, rear 410mm. Total swept area 6,497cm<sup>2</sup>.
- Air dryer.
- All steel tubing.
- Asbestos free lining material.
- Spring park brake acting on rear wheels.

### STEERING

- Fully integral, power assisted, recirculating ball type.
- Gear ratio 22.4 ~18.8 : 1. Turns lock to lock 3.5.
- Gear driven vane type oil pump. Oil capacity 2.5 litres.

### WHEELS AND TYRES

#### WHEELS:

- 7.00T x 20, 8 stud disc wheels.
- Number of wheels and tyres 7, including spare. Winch type spare wheel carrier.

#### TYRES:

9.00R20 140/137K Tubed Type radial ply tyres front and rear.

Type: Michelin XZY

Load & Speed Ratings per tyre:

2500kg (Single) / 2300kg (Dual) / 110km/h.

### ELECTRICAL SYSTEM

- Batteries - 2 x 12 volt / 65 amp/h, negative earth.
- Alternator - 24 volt / 40 amp.
- Starter motor - 24 volt / 4.5kW.
- Rear stop and tail lamps and licence plate lamp with long leads for variable body mounting.

# MODEL RATINGS AND DIMENSIONS

MODELS	RATINGS		TARE MASS <sup>†</sup>			DIMENSIONS (mm)								TURNING CIRCLE	NOMINAL MAX BODY LENGTH*	
	GVM	GCM	TOTAL	FRONT	REAR	WB	OAL	ROH	CA	CE	FFH UNLADEN	FFH LADEN	RFH UNLADEN	RFH LADEN	KERB TO KERB	mm
FSS 550 4x4	10,000kg	15,000kg	3,975kg	2,525kg	1,450kg	3,700	6,570	1,605	2,985	4,590	980	950	1,037	910	15.2m	4,765
FSS 550 Crew	10,000kg	15,000kg	4,165kg	2,660kg	1,505kg	4,200	7,270	1,800	2,795	4,595	980	950	1,037	910	17.2m	4,695
FTS 750 4x4	13,000kg	18,000kg / 20,500kg <sup>‡</sup>	4,660kg	2,900kg	1,760kg	4,250	7,420	1,900	3,535	5,435	1,089	1,060	1,169	1,040	17.7m	5,645
FTS 750 Crew	13,000kg	18,000kg / 20,500kg <sup>‡</sup>	4,840kg	3,030kg	1,810kg	4,250	7,420	1,900	2,845	4,745	1,089	1,060	1,169	1,040	17.7m	4,975

<sup>†</sup>18,000kg off road, 20,500kg on road

<sup>‡</sup>Estimated mass of cab/chassis with oil, water and fuel tank containing 10 litres of fuel and excluding spare wheel and tools.

\*Subject to weight distribution

FSS 550 4x4  
FTS 750 4x4

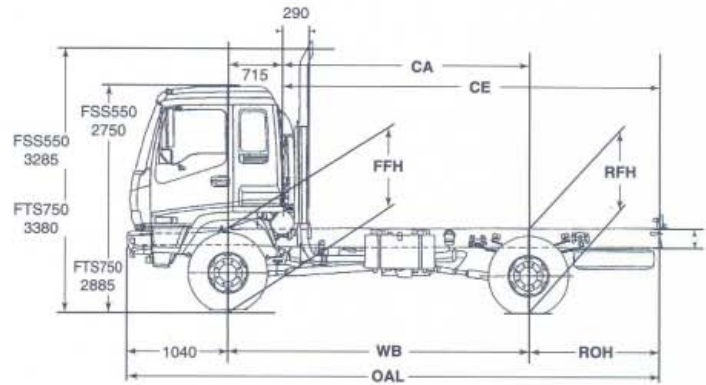
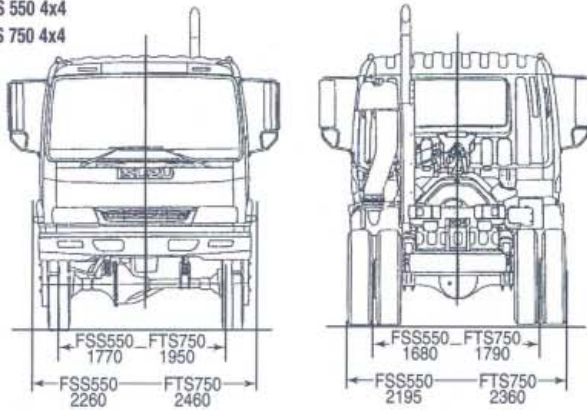

FSS 550 Crew  
FTS 750 Crew

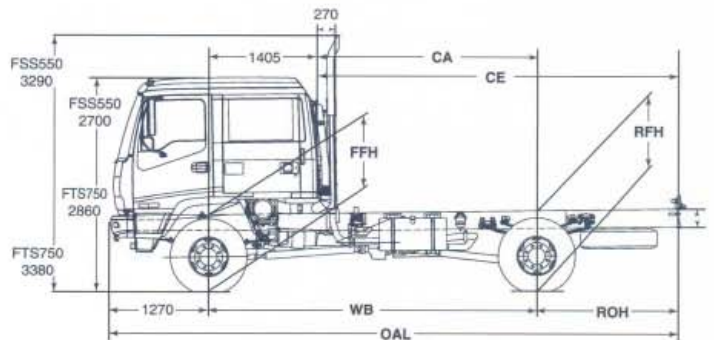
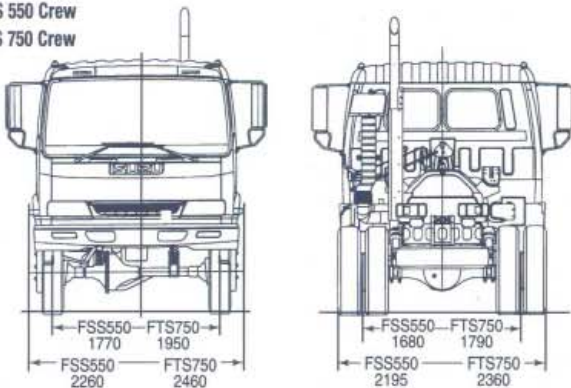

For further information regarding Cab/Chassis dimensions your Isuzu Dealer can access detailed Body Builders diagrams from the Isuzu Truck Data Manual.

## ISUZU NEW TRUCK WARRANTIES

12 MONTHS	24 MONTHS	36 MONTHS
<b>24</b> VEHICLE WARRANTY	24 MONTH NEW VEHICLE WARRANTY	TRUCKPOWER EXTENDED NEW VEHICLE WARRANTY*
<b>36</b> POWERTRAIN WARRANTY	36 MONTH POWERTRAIN WARRANTY	
<b>36</b> CAB CORROSION WARRANTY	36 MONTH CAB CORROSION WARRANTY	

**\*36 months or 150,000kms whichever occurs first.**

12 MONTHS	24 MONTHS	36 MONTHS	48 MONTHS
<b>24</b> VEHICLE WARRANTY	24 MONTH NEW VEHICLE WARRANTY	TRUCKPOWER EXTENDED NEW VEHICLE WARRANTY*	
<b>36</b> POWERTRAIN WARRANTY	36 MONTH POWERTRAIN WARRANTY		
<b>36</b> CAB CORROSION WARRANTY	36 MONTH CAB CORROSION WARRANTY		

**\*48 months or 200,000kms whichever occurs first.**

12 MONTHS	24 MONTHS	36 MONTHS	48 MONTHS	60 MONTHS
<b>24</b> VEHICLE WARRANTY	24 MONTH NEW VEHICLE WARRANTY	TRUCKPOWER EXTENDED NEW VEHICLE WARRANTY*		
<b>36</b> POWERTRAIN WARRANTY	36 MONTH POWERTRAIN WARRANTY			
<b>36</b> CAB CORROSION WARRANTY	36 MONTH CAB CORROSION WARRANTY			

**\*60 months or 250,000kms whichever occurs first.**

Subject to the conditions outlined in the I-GM New Vehicle Warranty, the Isuzu FSS & FTS models carry a standard factory warranty which covers the owner: (i) for the entire vehicle, for the first 24 months or 100,000km (whichever comes first) (ii) for the powertrain, which runs concurrently for 36 months or 150,000km (whichever comes first) (iii) against cab corrosion, for 36 months and unlimited kilometres.

A TruckPower Extended Warranty as illustrated is available by purchase to cover the owner against the failure of original components, but excludes some components and expendable items such as oil, filters, etc. Please consult with your Isuzu Dealer for full details obtainable from a dedicated brochure available to customers.

**ISUZU**  
RELIABILITY IS EVERYTHING

ISUZU-GENERAL MOTORS AUSTRALIA LTD A.C.N. 006 962 572. PLEASE NOTE: as the policy of I-GM is one of continual product improvement, all specifications and equipment are subject to change without notice. No I-GM dealer or other person is authorised or permitted to give or make any statement, assertion or undertaking in relation to the quality, performance, characteristics, descriptions or fitness for any purpose of any I-GM product or in connection with the supply of any I-GM product which is at variance with any written statement, assertion or undertaking in many parts of Australia, for the safe of service, parts and the provision of service to the owners of I-GM products. Every endeavour is made to ensure that such dealers carry adequate stocks of service parts and are equipped to provide satisfactory service, but makes no promise, other than that contained in the I-GM new vehicle warranty, that such parts or service facilities will be available or available at any specific location or at any particular time. A word about this specification sheet. We have tried to make it as comprehensive and factual as possible. However, since the time of printing some of the information you will find here may have been updated. Also, some of the equipment shown or described through this specification sheet may have been changed and/or is available at extra cost. And the right is reserved to make changes at any time without notice, in prices, colours, materials, equipment and models. Your I-GM dealer has details and before ordering, you should ask him/her to bring you up to date.