

450

FSR 450 CREW CAB

**GVM 9,000 kg
GCM 15,000 kg
WHEELBASE 4,200 mm**

ISUZU 6BD1 ENGINE PERFORMANCE

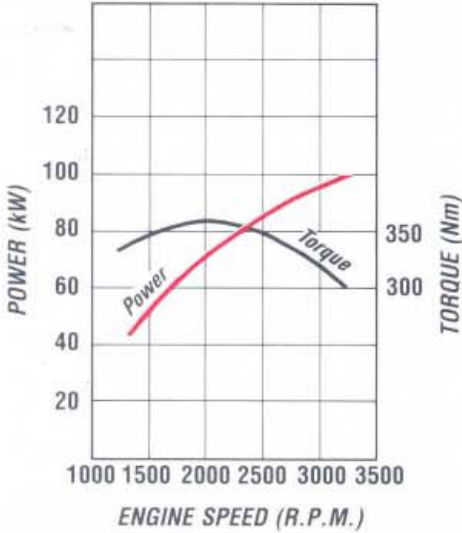

- Type: 6 Cylinder OHV Diesel, four stroke, direct injection
- Bore x Stroke (mm) 102 x 118
- Displacement 5785 (cc)
- Compression ratio (:1) 17.0
- Output-Power (kW) 100 @ 3200 rpm (DIN Nett)
- Torque (Nm) 353 @ 2000 rpm (DIN Nett)

DIMENSIONS

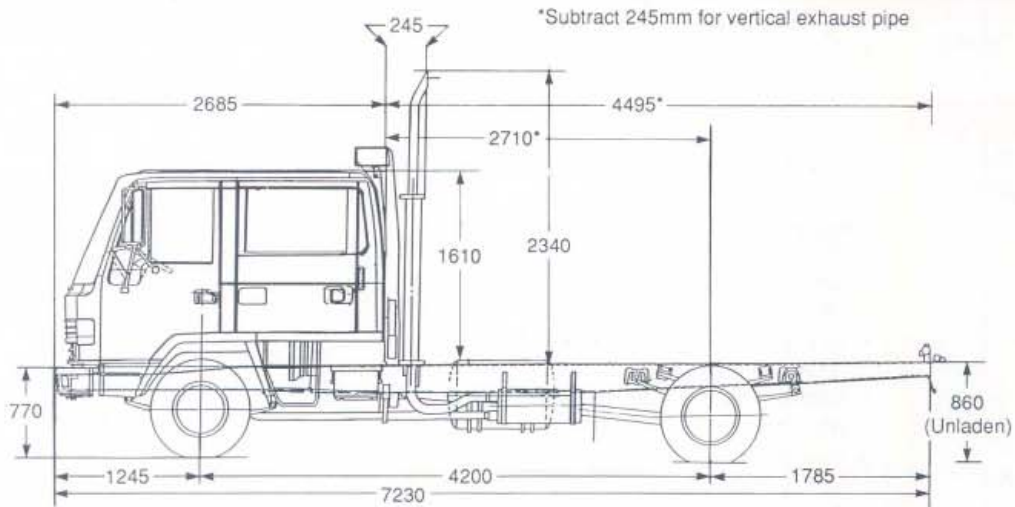

*ESTIMATED KERB MASS (kg)	
FRONT	2140
REAR	1150
TOTAL	3290
FRAME WIDTH (mm)	
	800
TURNING CIRCLE (m)	
kerb to kerb	13.6
BODY LENGTH (mm)	
	4870
Subject to weight distribution	

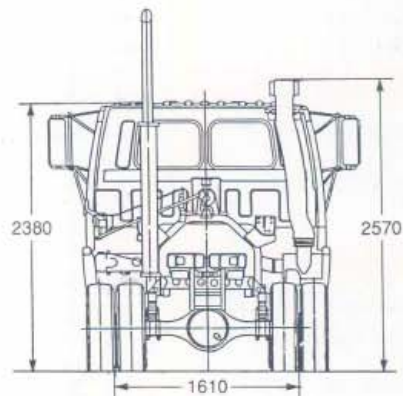

*Chassis and cab with oil, water and fuel tank containing 10 litres of fuel.

ISUZU-GENERAL MOTORS AUSTRALIA LTD A.C.N. 006 962 572

12/50 WARRANTY. Every Isuzu Truck is covered by the I-GM new vehicle warranty which covers your vehicle for the first 12 months or 50,000 kilometres.

PLEASE NOTE: as the policy of Isuzu-General Motors Australia Limited is one of continual product improvement, all specifications and equipment are subject to change without notice. Body illustrated are not standard. No I-GM dealer or other person is authorised or permitted to give or make any statement, assertion or undertaking in relation to the quality performance characteristics descriptions or fitness for any purpose of any I-GM product or in connection with the supply of any I-GM product which is at variance with any written statement assertion or undertaking on any of these subjects given or made by Isuzu-General Motors Australia Limited in its published sales literature, and the company accepts no liability for any such unauthorised action. Isuzu-General Motors Australia Limited has franchised dealers in many parts of Australia. For the sale of service parts and the provision of service to owners of I-GM products. Every endeavour is made to ensure that such dealers carry adequate stocks of service parts, and are equipped to provide satisfactory service, but makes no promise, other than that contained in the New Vehicle Warranty given by Isuzu-General Motors Australia Limited, that such parts or service facilities will be available, or available at any specific location or any particular time.

CT2913-10/91

ISUZU



ISUZU 450

FSR 450 CREW CAB

ORDERING CODE
8EF03-311

ENGINE-ISUZU 6BD1

Lubrication:

- Pressure feed lubrication with full flow, paper element filter, oil cooler. Oil capacity 12.5 litres including filter.

Cooling System:

- Six blade plastic cooling fan. Size 475mm Diameter.
- Tube and corrugated fin pressure type radiator size (mm) 662h x 559w x 53t frontal area 0.348m².

FUEL SYSTEM

- Two stage paper element air cleaner, Donaldson 9" with high vertical air intake stack and rain head.
- In line plunger, Bosch 'A' type fuel injection pump with mechanical all speed governor.
- In line paper filter, see through water separator with drain cock.
- Fuel tank capacity 200 litres.
- Horizontal exhaust muffler with vertical stack.

CLUTCH

- Hydraulic control, dry single plate with coil type cushioning springs. 325mm (13") Diameter, lining area 966cm² (Both sides).

TRANSMISSION - ISUZU MBG5A

- Five speed, direct drive, constant mesh, synchromesh on gears 2-5. Oil capacity 5 litres.

Gear Ratio:1

1st	6.378
2nd	3.627
3rd	2.239
4th	1.452
5th	1.000
Reverse	5.835

- Maximum geared speed 103km/h
- Two piece propeller shaft 90mm diameter

Length

1st section	1,028mm
2nd section	1,244mm

REAR AXLE - CAPACITY 7.700kg

- Banjo type, fully floating, single reduction. Ratio 4.750:1
- Hypoid type ring gear, 343mm diameter. Oil capacity 5.5 litres.

REAR SUSPENSION - CAPACITY 11.020kg

- Semi elliptical, alloy steel, tapered, multi leaf springs. Fully wrapped eye with greasable shackles.
- Size: Length x width x thickness
Main: 1300 x 70 x 11mm - 8 leaves
Auxiliary: 850 x 70 x 10mm - 7 leaves

FRONT AXLE - CAPACITY 3.400kg

- Reverse Elliot, I-beam type, King pin diameter 35mm with cylindrical roller thrust bearing.

FRONT SUSPENSION - CAPACITY 5.100kg

- Semi elliptical, alloy steel, tapered multi leaf springs. Fully wrapped eye with greasable shackles.
- Size: Length x width x thickness
1200 x 70 x 10mm - 8 leaves
- Hydraulic, double acting, telescopic shock absorbers.

STEERING

- Fully integral, power assisted, recirculating ball type. Gear ratio 22.4:1, Turns lock to lock 4.3
- Gear driven vane type oil pump, oil capacity 2.0 litres.

BRAKES

- Air over hydraulic, dual circuit, front two leading, rear dual two leading, drum diameter 320mm front and rear. Total lining area 3082cm².
- Spring parking brake acting on rear wheels.
- Butterfly, vacuum controlled exhaust brake system, activation switch on wiper/washer control stalk.

CHASSIS FRAME

- Parallel rail, ladder type, channel section, cold riveted.
- Side member dimensions - 225 x 70 x 6mm
- Frame reinforcement 189 x 4.5mm at back of cab.
- High tensile steel, HT55 weldable frame material.

WHEELS AND TYRES

- 6.00 GS x 16 - 6 stud disc wheels front & rear. 20mm bolt size
- 8.25 - 16lt - 14ply Yokohama Y785 Tubed radial tyres front and rear.
- Number of tyres 7, including spare.
- Winch type spare wheel carrier.

ELECTRICAL SYSTEM

- Batteries 2 x 12 volt - 53 amp/hour, negative earth
- Alternator 24 volt - 40 amp
- Starter motor 24 volt - 4.5kw output
- Rear stop and tail lamps and licence plate lamp with long leads for variable body mounting, turn signal side indicator lamps for body mounting.

CAB EXTERIOR

- All steel, power tilt four door cab. Cation electro deposition primer.
- Heavy duty bumper bar with four rectangular halogen head lamps inset.
- Combination turn signal and park lamps.
- West Coast type rear view mirrors with clearance lamps.
- Laminated windshield 2 speed wiper with intermittent mode and washers.
- Front side quarter vent windows.
- Corrosion resistant non slip cab front entry steps.

- Steel rear entry steps.
- Exterior grab handles on 'B' and 'C' pillars.
- Tool kit with 7,000 kg capacity jack.

CAB INTERIOR

- Air suspension driver's seat, reclining with seat slide and height control.
- Outboard passenger seat, folding centre seat back with lockable compartment and snack tray.
- Rear 4 seater bench seat.
- All outboard seats have lap/sash seat belts with emergency locking retractor, inboard seats have lap belts.
- Vinyl seat material, padded roof lining and heavy duty vinyl floor mat.
- Overhead parcel shelf with driver and passenger sunvisors.
- Easy entry grab handles on 'A' and 'B' pillars full length grab rail for rear passengers.
- Soft feel urethane steering wheel.
- Heater demister with 4 speed fan, 4 outlet vents to screen, 5 fascia outlets, 5 foot outlets.
- AM/FM radio with digital clock.
- Front and rear compartment lamps.

INSTRUMENTATION

- Speedometer, odometer and tachometer.
- Gauges for coolant temperature, fuel level and brake air pressure.
- Dash illumination control.

INDICATOR LAMPS

- Turn signals, parking brake on, high beam on exhaust brake engaged, brake fluid level.

WARNING LAMPS

- With warning bulb checking switch
- Battery charge, oil filter clogged, oil pressure, low air pressure, brake system, air cleaner clogged, stop and tail lamp failure.

SWITCHES

- Left side combination switch for exhaust brake, wipers and washers.
- Hazard lamp switch.
- Right side combination switch for headlamps, turn signals and headlamp dip.
- Key operation for engine stop and start, external engine crank switch for service when cab is tilted.
- 24 Volt 2 pin accessory plug on centre fascia panel.
- Three way switch for interior lamp activated by driver and passenger doors.