

# ISUZU

SPECIFICATIONS

**NEW**  
NEW GENERATION ISUZU  
**GEN**

## NQR 450 NQR 450 Crew



NQR 450 Crew



NQR 450

AUSTRALIA'S TOP SELLING TRUCK BRAND SINCE 1989. Truck tracker 2007.

### AT A GLANCE

<b>GVM</b>	8,700 kg
<b>GCM</b>	12,200 kg
<b>Power</b>	139 kW @ 2,600 rpm
<b>Torque</b>	510 Nm @ 1,600 - 2,600 rpm

### UPGRADE OPTIONS

#### Premium Pack:

- Automated Manual Transmission (AMT)
- Instrument panel multi-information display
- Cruise control
- Auto control for airconditioning
- Front foglamps
- Chrome grille

### ADVANCED TECHNOLOGY

- Driver and passenger airbag with seatbelt pretensioner
- Anti-lock Braking System (ABS)
- Anti Skid Regulator (ASR)
- Hill Start Aid (HSA) - except premium pack
- Electric mirrors
- Front and rear stabiliser bars

RELIABILITY IS EVERYTHING **ISUZU**

## Driveline & Chassis Specifications

### ENGINE: SITEC SERIES II 185 (ISUZU 4HK1-TCC)

- Type:** 4 cylinder 16 valve SOHC  
**Displacement:** 5,193 cc  
**Compression ratio:** 17.5:1  
**Bore x Stroke:** 115 mm x 125 mm  
**Max power (DIN - NET):** 139 kW (186 HP) @ 2,600 RPM  
 (JIS Gross): 144 kW (193 HP) @ 2,600 RPM  
**Max torque (DIN - NET):** 510 Nm (376 lb.ft) @ 1,600 - 2,600 RPM  
 (JIS Gross): 528 Nm (389 lb.ft) @ 1,600 - 2,600 RPM  
**Induction system:** Electronically controlled variable nozzle turbocharger with air-to-air intercooler.  
**Fuel injection:** Direct injection high pressure common rail system.  
**Emission control system:** Two-stage cooled EGR with exhaust Diesel Particulate Diffuser (DPD). ADR 80/02 (Euro IV) compliant.

### CLUTCH

- Standard model:**
- Auto adjusting hydraulic control with vacuum assistance. Single plate 325 mm diameter.
  - Total lining area: 966 cm<sup>2</sup>
- Premium Pack:**
- Fully automated hydraulically controlled wet clutch and fluid coupling with lock up.

### TRANSMISSION

#### ISUZU MZZ-6F

- PTO provision on LHS of transmission case. PTO drive from counter gear.
  - Gear ratios (: 1)
- | 1st   | 2nd   | 3rd   | 4th   | 5th   | 6th   | Rev   |
|-------|-------|-------|-------|-------|-------|-------|
| 6.369 | 3.767 | 1.966 | 1.355 | 1.000 | 0.782 | 6.369 |

#### Standard model:

- 6 speed manual. Synchromesh on gears 1-6.

#### Premium Pack:

- 6 speed Automated Manual Transmission (AMT) with both fully automatic and clutchless manual operation modes.

### AXLES

#### Front: Isuzu F031

- Reverse Elliot I-beam. 3,100 kg capacity.

#### Rear: Isuzu R066

- Full floating Banjo type. Four differential pinions. 6,600 kg capacity.
- Drive ratio: 4.100:1 (standard model), 4.300:1 (premium pack)

### SUSPENSION

#### Front:

- Single stage alloy steel multi leaf springs.
- Double acting hydraulic shock absorbers. Stabiliser bar.

#### Rear:

- Multi leaf main spring, multi leaf helper spring.
- Double acting hydraulic shock absorbers. Stabiliser bar.

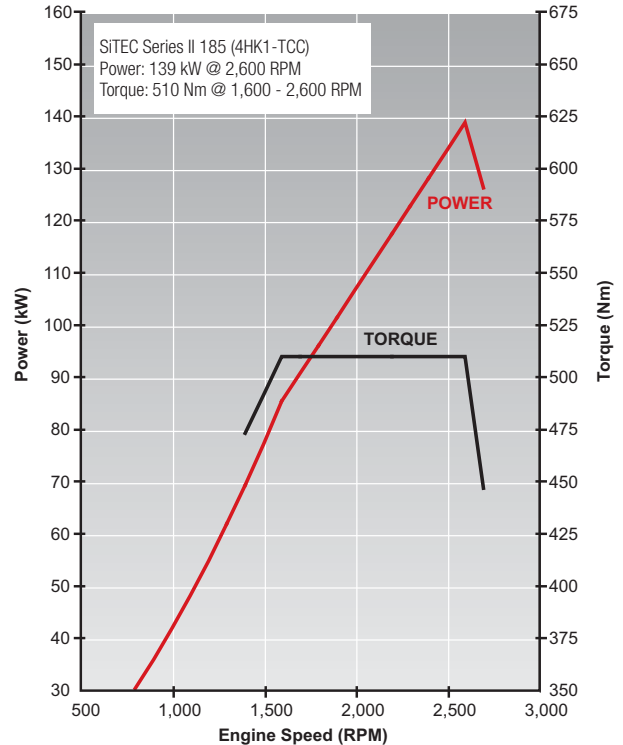

### BRAKES

- Auto adjusting front disc and rear drum brakes with dual circuit hydraulic control, hydraulic pressure assistance and electronic brake force distribution (EBD).
- ABS and ASR traction control.
- Hill Start Aid (HSA) - except premium pack.
- Front disc diameter: 363 mm
- Rear drum size: 370 x 150 mm
- 203 mm diameter drum park brake mounted on rear of transmission.
- Vacuum controlled exhaust brake.

### STEERING

- Power assisted recirculating ball steering.
- Gear ratio: 20.9:1
- Turns lock to lock: 5.4
- Maximum angle: 43° (inside wheel) / 33° (outside wheel)

### WHEELS AND TYRES

- 19.5 x 6.00 six stud steel wheels.
- 225/70R 19.5 125/123L Michelin XZE Tubeless.
- Maximum tyre rating:  
 Steer axle: 3,300 kg  
 Drive axle: 6,200 kg
- 1 frame mounted spare wheel and tyre assembly.

## CHASSIS FRAME

- Cold rivetted ladder frame. SAPH440 weldable steel sidemembers. Parallel side rails and rivetless top flange.
- Frame dimensions:
  - Side rail (mm): 216 x 70 x 6.0
  - Rear frame width (mm): 850

## FUEL TANK

- Frame mounted 140L steel fuel tank.
- Lockable fuel cap.

## ELECTRICAL SYSTEM

- 24 volt electrical system.
- 80 amp alternator.
- 4.5 kW starter motor.
- 2 x 80D26L (630 CCA) batteries connected in series.

## Cabin Specifications and Appointments

### CAB EXTERIOR

- All steel construction. High tensile steel used for cab underframe.
  - Single cab:** Manual cab tilt to 45° with torsion bar assistance.
  - Crew cab/single cab motorhome:** Fixed cab mounting.
- **Single cab:** Liquid filled front and rear cab mounts.
  - Crew cab/single cab motorhome:** Rubber cab mounts.
- Heavy duty non slip entry steps.
- 90° opening internally reinforced front doors.
- Water spray suppression guards and front mudflaps.
- Laminated windscreen with shade band.
- Two speed windscreen wipers with intermittent wipe mode.
- Halogen multi-reflector headlamps incorporating turn signals. Additional door mounted side indicator lamps.
- Combination brake, turn, reverse and marker lamps, registration plate illumination lamps. Extended wiring harness. Reverse alarm.
- Roof-mounted clearance lamps.
- Heated and powered exterior main mirrors with flat glass and additional independently adjustable convex "spot" mirrors.
- **Except Premium Pack:** Body coloured grille. **Premium Pack:** Chrome grille.
- Body coloured impact resisting polycarbonate bumper with steel backing frame.
  - Premium Pack:** Includes front foglamps.

### CAB INTERIOR

- Contoured adjustable driver's bucket seat.
- Front passenger bench seat with 2 seat capacity.
- **Crew cab/motorhome:** Engine access provided under removable driver seat base and tiltable front passenger seat.
- **Crew cab:** Rear bench seat with 4 seat capacity.
- 3-point lap sash seatbelts in all outboard seating positions. Driver and outboard front passenger seatbelts fitted with pre-tensioner. Centre seat lap belts.
- Driver and outboard front passenger airbag.
- **Premium Pack:** Driver's footrest.
- Door and roof pillar entry assist grips. **Crew cab:** Full width rear grab rail with ashtray.
- Full interior trim, padded roof lining and vinyl floor covering. Driver and passenger windscreen header storage shelf.
- Tilt/Telescopic adjustable steering column, soft feel urethane steering wheel.
- Electric windows.
- Central locking with remote keyless entry and immobiliser.
- Twin cup holders. 24V cigarette lighter. Dashboard hook.
- Front door mounted storage pockets and driver's side ashtray.
- Centre console box with storage tray. Fold down storage tray behind centre seat backrest.

- Fully integrated air conditioning and heater/demister with 4-speed fan and outlets for windscreen, side windows, face and floor. **Except Premium Pack:** Manual control. **Premium Pack:** Auto control.
- Interior lamp with On/Door/Off switch.
- 2 DIN, two speaker radio/CD multimedia unit. **NQR motorhome:** includes module for Bluetooth/iPod input/SD card reader/satellite navigation (includes NAVTEQ mapping).
- DIN sized compartment for storage or for CB radio installation.

### DRIVER CONTROLS

- Key-operated engine start/stop and steering lock. Engine idle speed control.
- HSA slow/fast engagement control and on/off switch (except premium pack).
- ASR on/off.
- DPD regeneration.
- **Premium Pack:** AMT slow/fast gear engagement control, 1st gear start and normal/economy gear selection modes.
- **Left side combination stalk:** Windscreen wipers, washers and exhaust brake.
- **Right side combination stalk:** Turn signals and headlamps. **Premium Pack:** Cruise control.

### INSTRUMENTATION

- Electronically driven speedometer and tachometer. Digital odometer with integrated dual tripmeter. Engine coolant temperature and fuel level gauges.
- **Warning lamps:** Check engine, oil pressure, ABS, SRS airbag, alternator charge, service brakes, park brake, seat belt unfastened, low fuel level. **Premium Pack:** Check AMT.
- **Indicator lamps:** HSA (except premium pack), warm up system, high beam, ASR, DPD status, exhaust brake, turn signals. **Premium Pack:** Cruise control, econo-mode, 1st gear start.
- **Premium Pack:** Gear selection display.
- **Premium Pack:** Multi-information display. Shows service interval, instantaneous and average fuel consumption, DPD bar chart, hourmeter, voltmeter, time/day/date and includes 40-120 km/h adjustable vehicle speed warning.

### OPTIONS AND GENUINE ACCESSORIES

Include the following (extra cost, check with dealer for availability):

- Module for Bluetooth/iPod input/SD card reader.
- Module for Bluetooth/iPod input/SD card reader/satellite navigation (includes NAVTEQ mapping) - except NQR motorhome.
- Up to two reversing cameras.
- Airbag compatible bullbar.
- 3,500 kg rated towbar.
- Cloth seat covers.

### Weights (kg)

Models	Ratings*		Loading Limit* (at ground)		Cab Chassis Mass#		
	GVM	GCM	Front	Rear	Front	Rear	Total
NQR 450 Medium	8,700	12,200	3,100	6,200	1,850	995	2,845
NQR 450 Long	8,700	12,200	3,100	6,200	1,910	1,040	2,950
NQR 450 Long Premium / Motorhome Premium	8,700	12,200	3,100	6,200	1,930	1,080	3,010
NQR 450 Crew	8,700	12,200	3,100	6,200	2,070	1,110	3,180
NQR 450 Crew Premium	8,700	12,200	3,100	6,200	2,090	1,120	3,210

Maximum Gross Trailer Mass: 750 kg (unbraked), 3,500 kg (braked) \* Vehicle ratings and front/rear weight limits are subject to government regulatory requirements and weight distribution analysis. Consult your Isuzu dealer to select the correct vehicle for your specific application. # Cab chassis only as supplied and including 10 litres of fuel.

### Dimensions (mm)

Models	WB	OAL	FOH	ROH	EA	CE	RT	ORT	CH	FFA (unladen)	RFA (unladen)	RFH (unladen)	Turn Circle (m)
													KERB TO KERB
NQR 450 Medium	3,365	5,985	1,110	1,510	2,680	4,302	1,670	2,150	2,280	710	815	855	12.4
NQR 450 Long / Long Motorhome	4,475	7,804	1,110	2,219	3,790	6,121	1,670	2,150	2,280	710	815	865	16.4
NQR 450 Crew	4,475	7,804	1,110	2,219	2,810	5,120	1,670	2,150	2,280	700	820	875	16.4

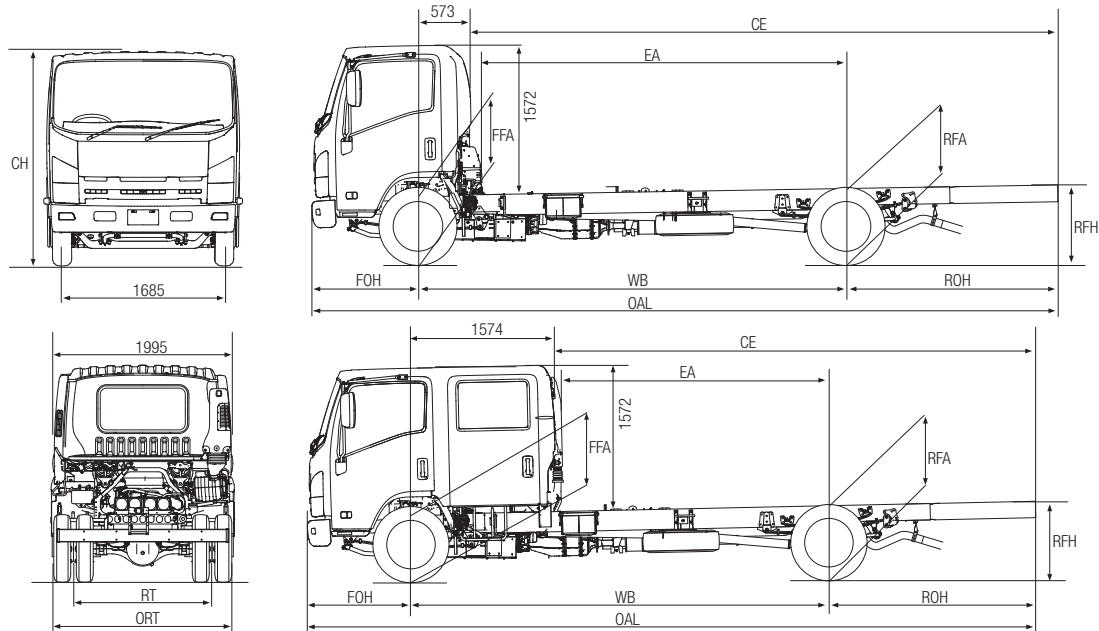

### Performance (calculated - typical paved road)

		Geared Speed* (top gear at peak power engine RPM)	Low Speed Gradeability (lowest forward gear assuming no wheel slip)	Engine Speed (top gear at 100 km/h)
NQR 450	At 8,700 kg GVM	121 km/h @ 2,600 RPM	35%	2,145 RPM
NQR 450 Premium Pack	At 8,700 kg GVM	116 km/h @ 2,600 RPM	37%	2,245 RPM

\* Maximum speed achievable depends on vehicle frontal area as well as other factors. Consult your Isuzu dealer for more detailed information.

### Isuzu Warranties

STANDARD <sup>1</sup>			
New Vehicle	3 years   100,000 km   2,000 hrs		
Cab Perforation Corrosion	3 years   Unlimited km		
EXTENDED <sup>2</sup>			
4 years   200,000 km	5 years   250,000 km	6 years   300,000 km	

<sup>1</sup> Subject to the conditions outlined in the IAL New Vehicle Warranty, the Isuzu NQR models carry a standard factory warranty which covers the owner: (i) for the entire vehicle, for the first 36 months or 100,000 km or 2,000 hrs (whichever comes first). (ii) against cab perforation corrosion, for 36 months and unlimited kilometres. <sup>2</sup> Extended Warranty as illustrated is available by purchase to cover the owner against the failure of original components, but may exclude some components and expendable items such as oil, filters, etc. Please consult with your Isuzu Dealer for full details obtained from a dedicated brochure available to customers.

ISUZU AUSTRALIA LIMITED ABN 97 006 962 572 ("IAL"). The information in this brochure was correct at time of printing, but all measurements, specifications and equipment are subject to change without notice. Some equipment may have been changed and/or is available at extra cost. IAL may make changes at any time without notice, in prices, colours, materials, equipment and models. IAL makes all reasonable attempts to ensure the availability of all vehicles and equipment. The information in this brochure is general in nature. Your Isuzu dealer can confirm all measurements, specifications and vehicle / equipment availability upon request.

July 2008. ARK0326