

ISUZU FVM 1400 Turbo 6x2 • LONG • LO-PROFILE

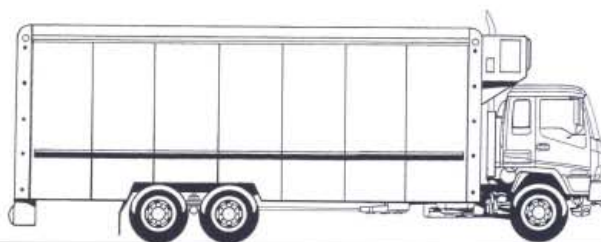
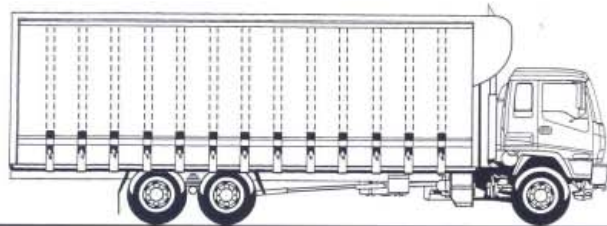

ENGINE ISUZU 6SD1-TC

- Type:** 6 cylinder, in line, overhead camshaft, direct injection, four stroke, diesel engine. Turbocharged and Air-To-Air Intercooled.
- Bore x Stroke:** 120 mm x 145 mm
- Displacement:** 9839 cc
- Compression Ratio:** 16.5:1
- Output - Power:** 199 kW @ 2200 RPM (ISO 1585)
- Torque:** 1,000 Nm @ 1500 RPM (ISO 1585)

CLUTCH

- Hydraulic control dry single plate with cushioning springs. Coil type pressure springs.
- Clutch disc diameter: 381 mm (15").
- Pneumatic clutch release assistance.
- Asbestos free lining material. Total lining area 1,363 cm².

TRANSMISSION EATON FS-8209

- Direct drive transmission. 8 synchronised, regular usage forward speeds. One forward crawler speed. 1 reverse speed.
- 'Repeat-H' shift pattern. Pre-selected and synchronised range change. Oil capacity 8.5 litres.
- Gear ratios (:1)

Low	1st	2nd	3rd	4th
12.64	8.81	6.55	4.77	3.55
Rev	5th	6th	7th	8th
13.21	2.48	1.85	1.34	1.00

- Maximum geared speed:
FVM 1400 6x2 LONG: 115 km/h.
FVM 1400 LO-PROFILE: 105 km/h.
- Electronically road speed limited to 100 km/h.

REAR AXLES ISUZU RT165 CAPACITY 16,500 KG

- Drive & Lazy Tandem axle set with 1,300 mm tandem axle centre spacing.
- Banjo, fully floating, single reduction type drive axle. Final drive ratio 3.909:1
- Hypoid type ring gear 445 mm diameter. Oil capacity 13.0 litres.

BRAKES

- Full Air, 'S'-Cam, dual circuit brake system with front and rear leading and trailing shoes. Asbestos free brake shoe lining material.
- Drum diameters (front and rear): 410 mm.
- Brake drum swept areas:
12,881 cm² total: 3,607 cm² front, 9,274 cm² rear.
- Air reservoir capacities:
Supply Tank Front Service Tank Rear Service Tank
28.5 litres 22.4 litres 35.0 litres
Parking Brake Tank
11.0 litres.
- Air Compressor 85 mm Bore x 60 mm Stroke (340 cm³ / revolution), gear driven at half engine speed, water cooled. Nylon brake air tubing.
- Spring park brake acting on all rear wheels.
- Air controlled, butterfly type exhaust brake.

FVM 1400 MODEL:	WHEELBASE	GVM	GCM	ORDERING CODE
6x2 LONG	6,470 mm	22,500 kg	32,000 kg	8FT02-781
LO-PROFILE	6,470 mm	22,500 kg	32,000 kg	8FT02-784

KERB MASS (kg)*

FVM 1400 Model:	Front	Rear	Total
6x2 LONG	3,195	3,390	6,585
LO-PROFILE	3,175	3,360	6,535

*Estimated mass of chassis cab with oil, water and fuel tank containing 10 litres of fuel. Excluding spare wheel and tools.

DIMENSIONS (mm) *

	6x2 LONG	LO-PROFILE
Wheelbase (WB)	6,470	6,470
Overall Length (OAL)	11,165	11,165
Rear Overhang (ROH)	3,425	3,425
Cab to Axle (CA)	5,760	5,760
Cab to End of Frame (CE)	9,185	9,185
Front Frame Height, Unladen (FFH)	980	935
Front Frame Height, Laden (FFH)	935	890
Rear Frame Height, Unladen (RFH)	965	920
Rear Frame Height, Laden (RFH)	940	895
Turning Circle (Kerb to Kerb)	20.1	20.1
Nominal Max. Body Length#	8,815	8,815

*Except Turning Circle: metres. *Subject to weight distribution

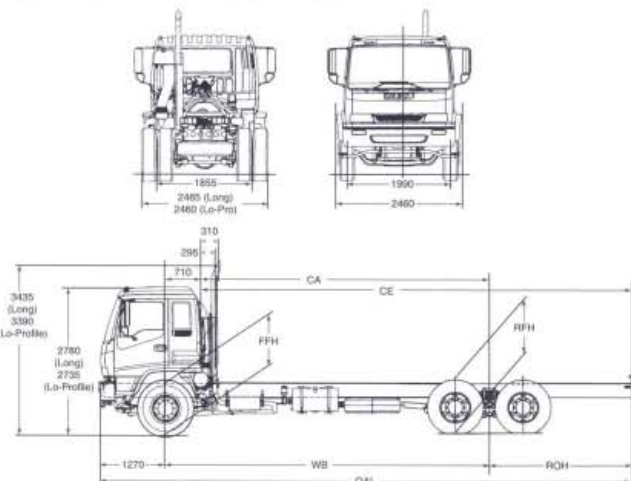

ISUZU GENERAL MOTORS AUSTRALIA LTD (G.A.S. 806 90 577) subject to the conditions of the ISUZU New Vehicle Warranty, every Isuzu Turbo F-Series Truck carries a warranty which covers your vehicle for the first 24 months or 130,000 kms (whichever comes first). A 30 months or 390,000 kms (whichever comes first) power train warranty runs concurrently with the new vehicle warranty, as does a 36 months (unlimited kms) labour and materials warranty. PLEASE NOTE: as the maker of ISUZU (G.M.) of continued product improvement, all specifications and equipment are subject to change without notice. The body dimensions shown are for standard equipment. No ISUZU dealer or other person is authorised to present or make any warranty, assertion or undertaking in relation to the quality, performance, characteristics, description or fitness for any purpose of any ISUZU product or in connection with the supply of any ISUZU product which is in variance with any written statement, assertion or undertaking on any of these subjects given or made by ISUZU in its published sales literature and the company accepts no liability for any such statement and claims. ISUZU (G.M.) has franchise dealers in many parts of Australia for the sale of its parts and the provision of service to the owners of ISUZU products. Every endeavour is made to ensure that such dealers carry adequate stocks of service parts and are equipped to provide satisfactory service, but makes no promise other than that equipment to the ISUZU New Vehicle Warranty. That such parts or service facilities will be available or available at any specific location at any particular time. A word about this specific notice: We have tried to make it as comprehensive and factual as possible. However, since the time of printing some of the information you will find here may have been updated. Also, some of the equipment shown or described through this specification sheet may have been changed and/or is available at extra cost. And the right is reserved to make changes of any kind without notice, in prices, colours, materials, equipment and models. Your ISUZU dealer has details and before ordering, you should ask him/her to bring you up to date.

ISUZU

RELIABILITY IS EVERYTHING

AIR INTAKE SYSTEM

- Donaldson 13" diameter, dry element, two stage filter. Vertical intake stack with rain head.
- Turbocharger and Air-To-Air Intercooler. Intercooler dimensions: 540 mm x 470 mm x 53 mm. Total intercooler frontal area 2,540 cm².

CHASSIS FRAME

- Parallel rail, ladder type, channel section, cold riveted.
- Straight frame for easy body mounting. 850 mm frame width.
- Rear crossmember and spring hanger brackets bolted to frame allowing easy wheelbase modification.
- Frame side member dimensions: 258 mm x 85 mm x 10 mm.
- Frame reinforcement angle section: 224 x 85 x 4.5 mm.
- Frame material: SAPH440 weldable mild steel.

COOLING SYSTEM

- 6 blade plastic cooling fan 600 mm diameter with bell-mouth fan shroud and dual drive belts.
- Bimetallic controlled, thermatic fan clutch.
- Tube and corrugated fin, pressure type radiator. Dimensions: 800 mm x 636 mm x 54 mm. Frontal area 5,088 cm².
- Coolant capacity 29.0 litres.

ELECTRICAL SYSTEM

- Batteries: 2 x 12 Volt / 65 Amp/h, negative earth.
- Alternator: 24 Volt / 40 Amp.
- Starting Motor: 24 Volt / 5.5 kW.
- Rear stop, turn, reverse and tail lamp assemblies and licence plate lamp with long leads for variable body mounting.

EXHAUST SYSTEM

- Horizontal muffler with vertical exhaust pipe.
- Air controlled, butterfly type exhaust brake.

FRONT AXLE ISUZU F063 CAPACITY 6,300 KG

- Reverse Elliot I-beam type.
- King Pin diameter 50 mm with cylindrical roller thrust bearing.

FRONT SUSPENSION CAPACITY 6,000 KG

- Semi-elliptical, alloy steel tapered multi-leaf springs. Fully wrapped spring eye with greasable shackles.

Length	x	Width	x	Thickness	x	No. leaves
1,470 mm	x	80 mm	x	12 mm	x	2
		80 mm	x	13 mm	x	5
		80 mm	x	11 mm	x	2

- Stabiliser bar.
- Hydraulic, double acting, telescopic shock absorbers.

FUEL SYSTEM

- In line plunger, Bosch 'AP' type fuel injection pump with 'RLD' mechanical all-speed governor.
- Electronic road speed limiter.
- In line, paper element filter. See-through water separator with drain cock.
- Single fuel tank, 180 litre capacity, mounted on passenger side chassis rail.

LUBRICATION SYSTEM

- Pressure feed lubrication system. Gear driven, gear type oil pump.
- Full-flow and partial-flow bypass oil filter canisters.
- Plate type oil cooler in engine water jacket.
- Oil capacity 28.5 litres (including filters).

PROPELLER SHAFT

- 3-piece, 114.3 mm diameter propeller shaft with 2 support bearing assemblies.
- 1st Section Length: 912 mm
- 2nd Section Length: 1,127 mm
- 3rd Section Length: 1,344 mm

REAR SUSPENSION CAPACITY 16,500 KG

- Isuzu 6-Rod and trunnion axle location system. Inverted, semi-elliptical, alloy steel, tapered multi-leaf springs. Tandem axle centres: 1300 mm.

Length	x	Width	x	Thickness	x	No. leaves
1,300 mm	x	80 mm	x	20 mm	x	11

STEERING

- Fully integral power assisted recirculating ball and nut type. Gear ratio 22.4:1. Turns lock to lock: 5.4.
- Gear driven, vane type oil pump. See-through oil reservoir.
- Oil capacity 2.5 litres (including reservoir).

TOOLS

- Lockable tool box with 10,000 kg capacity jack. Wheel changing tools. Tool kit.

WHEELS AND TYRES

- 8.25 x 22.5 - 10 stud ISO standard (hub piloted) disc wheels. Stud size: 22 mm. Offset: 165 mm.
- Goodyear G391 tubeless radial tyres fitted front and rear.
- Tyre Size: FVM 1400 6x2 LONG: 11R22.5-16 Ply Rating. FVM 1400 LO-PROFILE: 275/70R22.5-16 Ply Rating.
- Winch type spare wheel carrier, mounted on chassis frame on passenger side.
- Number of wheels and tyres: 11 (including spare).

CABIN EXTERIOR

- All steel cab with welded strengthening ribs and side door impact beams. Torsion bar assisted cabin tilt to 45°.
- Four point cabin suspension utilising silicone filled rubber isolators.
- Cation electrodeposition primer.
- Heavy duty bumper bar with step holes and footplate.
- Halogen headlamps, hinged for easy bulb replacement.
- Park lamps and cabin clearance lamps.
- Turn signal lamps in front bumper and over wheel arches.
- 2 speed windscreen wiper / washer system with variable intermittent mode. Triple washer jets mounted on wiper arms.
- Tinted and laminated windscreen. Tinted and toughened side and rear glass.
- 'West Coast' type rear view mirrors. Convex mirror surface on passenger side.
- Alloy, non-slip cabin entry steps.
- Lift-up front panel for access to clutch and windscreen washer fluids without tilting the cabin. Engine fluid check points at rear of cabin.

CAB INTERIOR

- Fully trimmed cab interior with cloth seat facings, formed roof lining and overhead storage lockers. Driver and passenger sun visors.
- Pull-out drinks holder in centre fascia. Cigarette lighter (24 Volt). Ash trays in doors.
- Driver's seat with mechanical suspension and 3-position lumbar support mechanism. Adjustment for fore-aft position, seat back recline and driver weight.
- Outboard reclining passenger seat with under seat storage drawer. Folding centre seat back with lockable compartment and tray.
- Outboard lap/sash seat belts with emergency locking retractors, centre lap seat belt.
- Tilt/telescopic adjustable steering column with single release lever. Soft feel urethane steering wheel with zero offset to driver's seat.
- Easy entry grab handles on 'A' and 'B' pillars.
- Heater/Demister with 4 speed fan, 4 outlet vents to screen, 5 fascia outlets, 5 foot outlets, demister ducts to door glass.
- Optional fully integrated air conditioning.
- Dash mounted AM/FM Radio Cassette with digital clock.
- DIN standard aperture in dash for CB radio.
- Park brake activation lever at left side of driver's seat.
- Combination passenger-side dash storage tray/fuse panel cover.
- Interior rear vision mirror.
- Passenger side assist grip.
- Driver's left foot rest.
- Exhaust vents at rear/upper of cabin.
- Business card clip. Coat hook at rear of cabin.
- Elastic mesh pocket on driver's door.
- 24 Volt, 2-Pin accessory plug in centre console.

INSTRUMENTATION

- Speedometer, Odometer, Trip Meter and Tachometer.
- Coolant Temperature and Fuel Level Gauges. Dual brake air pressure gauge.

INDICATOR LAMPS

- Turn Signals On; Parking Brake On; High Beam On; Exhaust Brake Enabled.

WARNING LAMPS AND ALARMS

- Warning lamps for: Low Battery Charge; Low Engine Oil Pressure; Low Air Pressure; Stop And/Or Tail Lamp Failure.
- Warning lamp bulb check switch.
- Reversing Lamps and audible alarm.

CONTROLS

- Left side combination stalk control for exhaust brake, windscreen wipers and washers and hazard lamps.
- Right side combination stalk control for headlamps, high beam and turn signals.
- Engine idle speed adjust control.
- Key operation for engine start and stop. External engine crank switch for service when cab is tilted.
- Three way switch for interior lamp (Off / On / On By Driver Or Passenger Door).

FVM 1400 • LONG
• LO-PROFILE

ISUZU
RELIABILITY IS EVERYTHING