



FVD950

HEAVY DUTY

Cab/Chassis specification as at September 2000.

MODEL RATINGS AND DIMENSIONS

MODELS	ENGINE	RATINGS (kg)		TARE MASS* (kg)			DIMENSIONS (mm)								TURNING CIRCLE		
		GVM	GCM	TOTAL	FRONT	REAR	WB	OAL	FOH	ROH	CA	CE	FFH UNLADEN	FFH LADEN	RFH UNLADEN	RFH LADEN	KERB TO KERB
FVD950: HD LONG	SITEC270	16,000	32,000	5,170	3,110	2,060	6,050	10,020	1,270	2,700	5,340	8,040	950	905	1,000	1,000	20.1m
HD LOPROFILE				5,140	3,100	2,040							905	860	955	955	20.1m
HD AUTO				5,115	3,070	2,045							5,550	9,270	1,270	2,450	4,840

* Estimated mass of cab/chassis with oil, water and fuel tank containing 10 litres of fuel and excluding spare wheel (95kg) and tools (30kg).
Note: Retarder adds 50kg

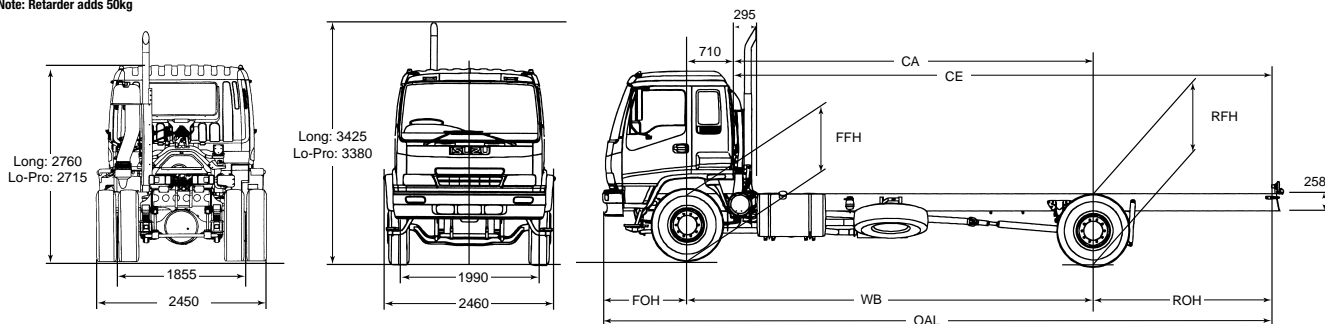

For further information regarding Cab/Chassis dimensions your Isuzu Dealer can access detailed Body Builders diagrams from the Isuzu Truck Data Manual.

DRIVELINE SPECIFICATIONS

ENGINE: ISUZU SITEC 270

Isuzu 6SD1-TC 6 cylinder, in line, overhead camshaft, four stroke, direct injection, diesel.

Turbocharged and Air-To-Air Intercooled.

BORE X STROKE: 120 mm x 145 mm.

DISPLACEMENT: 9,839 cc.

COMPRESSION RATIO: 16.5 : 1.

POWER: 199 kW @ 2,200 RPM. (ISO 1585)

TORQUE: 1,000 Nm @ 1,500RPM. (ISO 1585)

COOLING SYSTEM

- 6 blade plastic cooling fan 600 mm diameter with bell-mouth fan shroud and dual drive belts.
- Bimetallic controlled, thermatic fan clutch.
- Tube and corrugated fin, pressure type radiator. Dimensions: 800 mm x 636 mm x 54 mm. Frontal area 5,088 cm².
- Coolant capacity 29.0 litres.

AIR INTAKE SYSTEM

- Donaldson 13" diameter, dry element, two stage filter. Vertical intake stack with rain head.
- Intercooler dimensions: 540 mm x 470 mm x 53 mm. Total intercooler frontal area 2,540 cm².

EXHAUST SYSTEM

- Horizontal exhaust muffler with vertical exhaust pipe.
- Air controlled, butterfly type exhaust brake.

FUEL SYSTEM

- In line plunger, Bosch 'AP' type fuel injection pump with 'RLD' mechanical all speed governor.
- Electronic road speed limiter.

- In line, paper element filter, see through water separator with drain cock.
- Single aluminium fuel tank: 400 litres capacity.

TRANSMISSION

EATON FS-8209A 9 speed direct drive

- 8 synchronised, regular usage forward speeds. One forward crawler speed. 1 reverse speed. Oil capacity 8.5 litres.
- 'Repeat-H' shift pattern. Pre-selected and synchronised range change.
- Gear ratios to 1:

Low	1st	2nd	3rd	4th
12.64	8.81	6.55	4.77	3.55
Rev	5th	6th	7th	8th
13.21	2.48	1.85	1.34	1.00

- Maximum geared speed:
FVD 950 H.D. LONG: 118 km/h.
FVD 950 H.D. LO-PROFILE: 118 km/h.

ALLISON MD3060P 6 speed overdrive

- Automatic Transmission with electronic control.
 - Oil capacity: 24 litres
 - Gear ratios to 1:
- | | | | | | | |
|------|------|------|------|------|------|------|
| 1st | 2nd | 3rd | 4th | 5th | 6th | Rev |
| 3.49 | 1.86 | 1.41 | 1.00 | 0.75 | 0.65 | 5.03 |

- Maximum geared speed:
FVD 950 HD Auto: 110km/h
- Torque converter stall ratio: 2.02:1
- Electronically road speed limited to 100km/h.

CLUTCH

- Hydraulic control dry single plate with cushioning springs. Coil type pressure springs. Asbestos free lining material.
- Pneumatic clutch release assistance.
- Clutch disk diameter 381 mm (15") diameter.
- Total lining area (both sides) 1,363 cm².

FRONT AXLE

MERITOR FG941 CAPACITY 6,600KG

- Reverse Elliot I-beam type.
- 45° maximum wheel cut angle.
- Oil bath lubricated front wheel hubs with see-through oil level indicator.

REAR AXLE

MERITOR RS-23-161G CAPACITY 10,400KG

- Banjo type, fully floating, single reduction.
- Rear Axle Ratio: FVD 950 HD Long: 3.909
Lo-Profile: 3.583
Auto: 6.429
- Hypoid type ring gear, 457 mm diameter. Oil capacity 15.0 litres.

ISUZU

RELIABILITY IS EVERYTHING

ISUZU-GENERAL MOTORS AUSTRALIA LTD A.C.N. 006 962 572. PLEASE NOTE: as the policy of I-GM is one of continual product improvement, all specifications and equipment are subject to change without notice. No I-GM dealer or other person is authorised or permitted to give or make any statement, assertion or undertaking in relation to the quality, performance, characteristics, descriptions or fitness for any purpose of any I-GM product or in connection with the supply of any I-GM product which is at variance with any written statement, assertion or undertaking on any of these subjects given or made by I-GM in its published sales literature, and the company accepts no liability for any such unauthorised action. I-GM has franchised dealers in many parts of Australia, for the sale of service, parts and the provision of service to the owners of I-GM products. Every endeavour is made to ensure that such dealers carry adequate stocks of service parts and are equipped to provide satisfactory service, but makes no promise, other than that contained in the I-GM new vehicle warranty, that such parts or service facilities will be available or available at any specific location or at any particular time. A word about this specification sheet. We have tried to make it as comprehensive and factual as possible. However, since the time of printing some of the information you will find here may have been updated. Also, some of the equipment shown or described through this specification sheet may have been changed and/or is available at extra cost. And the right is reserved to make changes at any time without notice, in prices, colours, materials, equipment and models. Your I-GM dealer has details and before ordering, you should ask him/her to bring you up to date.

CABIN SPECIFICATIONS AND APPOINTMENTS

CAB EXTERIOR

- All steel cab with welded strengthening ribs and side door impact beams. Torsion bar assisted cabin tilt to 45°.
- Four point cabin suspension utilising silicone filled rubber isolators.
- Cation electrodeposition primer.
- Heavy duty bumper bar with step holes and footplate.
- Halogen headlamps, hinged for easy bulb replacement.
- Park lamps and cabin clearance lamps.
- Turn signal lamps in front bumper and over wheel arches.
- 2 speed windscreen wiper / washer system with variable intermittent mode. Triple washer jets mounted on wiper arms.
- Tinted and laminated windscreen. Tinted and toughened side and rear glass.
- 'West Coast' type rear view mirrors. Additional separately adjusted spotter mirror on each side.
- Alloy, non-slip cabin entry steps.
- Lift-up front panel for access to clutch and windscreen washer fluids without tilting the cabin. Engine fluid check points at rear of cabin.

CAB INTERIOR

- Fully trimmed cab interior with cloth seat facings, formed roof lining. Overhead storage lockers. Driver and passenger sun visors.
- Pull out drinks holder in centre fascia, cigarette lighter with ash trays in doors.
- Isringhausen ISRI 6500/517 air suspension driver's seat with auto weight adjustment to 130kg. Height, rake and back rest recline adjustment. Pneumatic lumbar support.
- Outboard reclining passenger seat with under seat

storage drawer. Folding centre seat back with lockable compartment and tray.

- Outboard lap/sash seat belts with emergency locking retractors, centre lap seat belt.
- Tilt/telescopic adjustable steering column with single release lever. Soft feel urethane steering wheel with zero offset to driver's seat.
- Easy entry grab handles on 'A' and 'B' pillars.
- Heater demister with 4 speed fan, 4 outlet vents to screen, 5 fascia outlets, 5 foot outlets, demister ducts to door glass.
- Optional fully integrated air conditioning.
- Eurovox AM/FM radio cassette with digital clock, dash mounted. Remote seek/volume and mute switch located on dash to right of steering wheel.
- Optional 6-stack CD player.
- DIN standard aperture in dash for CB radio.
- 12 Volt /100W cigarette lighter type electrical socket located in centre console.
- 24 Volt – 2 pin accessory plug in centre console.
- Park brake activation lever at left side of driver's seat.
- Combination passenger-side dash storage tray/fuse panel cover.
- Interior rear vision mirror.
- Passenger side assist grip.
- Driver's left foot rest.
- Exhaust vents rear/upper cab.
- Business card clip. Coat hook at rear of cab.
- Elastic mesh pocket on driver's door.

CUSTOM CAB (OPTIONAL)

(available on FVD 950 HD Long & Lo Profile models)

Features in addition to, or replacing standard cab features:

- Exterior
- Gold badging
- Griffin emblem

- "Custom" badge
 - Chrome radiator grille and head lamp surround
- ### Interior
- Fluorescent interior lamp
 - Carpeted cabin floor
 - Woodgrain appearance to instrument panel
 - 6 stack CD player
 - Premium speakers for sound system
 - Power windows
 - Power door locks with keyless entry
 - Auto-sensor headlamp switch

CONTROLS

- Left side combination stalk switch for exhaust brake, windscreen wipers and washer, hazard lamps.
- Right side combination stalk switch for headlamps, high beam and turn signals.
- Engine idle speed adjust control.
- Key operation for engine start and stop, external engine crank switch for service when cab is tilted.
- 3 way switch for interior lamp activated by driver's door.

INSTRUMENTATION

- GAUGES: Speedometer, odometer, trip meter and tachometer. Gauges for coolant temperature, fuel level and brake air pressure.
- WARNING LAMPS: With warning bulb check switch. Battery charge, oil pressure, low air pressure, brake system, stop and tail light failure.
- INDICATOR LAMPS: Turn signals, parking brake on, high beam on, exhaust brake engaged. Reversing lamp and beeper.

TOOLS

- Lockable tool box 10,000kg capacity jack and wheel changing tools.

* Folding centre seat not available on the FVD950 Heavy Duty auto.

CHASSIS SPECIFICATIONS

CHASSIS FRAME

- Parallel rail, ladder type, channel section, cold riveted.
- Straight frame for easy body mounting. 850 mm frame width.
- Rear crossmember and spring hanger brackets bolted to frame allowing easy wheelbase modification.
- Frame side member dimensions: 258 mm x 85 mm x 10 mm.
- Frame reinforcement angle 'L' section: 224 x 85 x 4.5 mm and 224 x 85 x 6.0 mm.
- Frame material: SAPH440 weldable mild steel.

SUSPENSION

FRONT

- Alloy steel tapered leaf springs. Fully wrapped eye with greasable shackles.
- 1,600mm x 80mm x 3 leaves.
- Stabiliser bar.
- Hydraulic, double acting, telescopic shock absorbers.

REAR

- Hendrickson HAS230 Airbag. Capacity 10,400kg. Featuring two rolling lobe air springs, proprietary "Z-beam" main support members, transverse torque rod and stamped steel cross channels for excellent roll stability.
- Outboard mounted, double acting shock absorbers.
- Dual height control valves.

BRAKES

- Meritor 'Q-Plus' full air, 'S'-cam, dual circuit brake system with front and rear leading and trailing shoes. Asbestos free brake shoe lining material.
- Drum diameters (front and rear): 419 mm.
- Brake drum swept areas: 8,030 cm². Total lining area 4,864cm².
- Air reservoir capacity: 78.5 litres in total. Aluminium air tanks mounted inside chassis frame.
- Spring park brake acting on rear wheels.
- Air controlled, butterfly type exhaust brake.
- Nylon brake air tubing.
- Air dryer.
- Automatic slack adjusters.
- **Isuzu permanent magnet retarder.** (Option available with 6,050mm wheelbase).
- Maximum retardation 470Nm. Operates in conjunction with butterfly type exhaust brake.

STEERING

- Fully integral power assisted recirculating ball and nut type.
- Gear ratio 22.4 : 1. Turns lock to lock 4.5.
- Gear driven vane type oil pump. See-through oil reservoir. Oil capacity 2.5 litres (inc. reservoir).

WHEELS AND TYRES

- 8.25 x 22.5, 10 stud ISO standard (hub piloted) disc wheels. Stud size: 22mm. Offset: 165mm.
- FVD 950 Long & Auto: 11R22.5 148/145L tubeless radial tyres front and rear. Type: Michelin XZE1 (Front and Spare) Michelin XDE2 (Rear)
- FVD 950 Lo Profile: 275/70R22.5 148/145L tubeless radial tyres front and rear. Type: Michelin XZE2 (Front and Spare) Michelin XDE2 (Rear)
- Load and speed ratings per tyre: 3,150kg (single) / 2,900kg (dual) 120 km/h: FVD Long & Auto. 130 km/h: FVD Lo Profile.
- Winch type spare wheel carrier, mounted on chassis frame on passenger side.
- Number of wheels and tyres 7, including spare.

ELECTRICAL SYSTEM

- Batteries – 2 x 12 volt / 65 amp/h, negative earth.
- Alternator – 24 volt / 60 Amps (1.5 kW) output.
- Starter motor – 24 volt / 4.5 kW.
- Rear stop and tail lamps and licence plate lamp with long leads for variable body mounting.

ISUZU NEW TRUCK WARRANTIES

	STANDARD TRUCKPOWER WARRANTY*		TRUCKPOWER EXTENDED WARRANTY OPTIONS#		
NEW VEHICLE	2 years	150,000km	3 years / 200,000km	4 years / 250,000km	5 years / 300,000km
DRIVETRAIN	3 years	200,000km			
CAB CORROSION	3 years	unlimited			

* Subject to the conditions outlined in the I-GM New Vehicle Warranty, the Isuzu FVD Heavy Duty models carry a standard factory warranty which covers the owner: (i) for the entire vehicle, for the first 24 months or 150,000km (whichever comes first) (ii) for the powertrain, which runs concurrently for 36 months or 200,000km (whichever comes first) (iii) against cab corrosion, for 36 months and unlimited kilometres.

A TruckPower Extended Warranty as illustrated is available by purchase to cover the owner against the failure of original components, but excludes some components and expendable items such as oil, filters, etc. Please consult with your Isuzu Dealer for full details obtainable from a dedicated brochure available to customers.