

ISUZU

SPECIFICATIONS

NPR 300 CNG

AMT



AUSTRALIA'S TOP SELLING TRUCK BRAND SINCE 1989.

AT A GLANCE

GVM	7,000 kg
GCM	10,500 kg
Power	96 kW @ 3,200 rpm
Torque	353 Nm @ 1,400 rpm

ADVANCED TECHNOLOGY

Emissions: JNLT 05 - meets ADR 80/03	ECE-R29 compliant cab
Meets EEV emissions standard	Anti-lock Braking System (ABS)
Multipoint injected CNG engine	Idle stop fuel saving system
Driver and passenger airbag with seatbelt pretensioner	Electric mirrors
	Front and rear stabiliser bars



THE
one

ISUZU
RELIABILITY IS EVERYTHING

DRIVELINE AND CHASSIS SPECIFICATIONS

ENGINE: CNG 130 (ISUZU 4HV1)

- Type:** 4 cylinder SOHC
- Displacement:** 4,570 cc
- Compression ratio:** 12.5:1
- Bore x Stroke:** 115 mm x 110 mm
- Max power (JIS D 1001 - NET):** 96 kW (129 HP) @ 3,200 RPM
- Max torque (JIS D 1001 - NET):** 353 Nm (260 lb.ft) @ 1,400 RPM
- Induction system:** Naturally aspirated.
- Ignition system:** Direct coil-over-spark plug ignition.
- Fuel injection:** Multipoint CNG injection.
- Emission control system:** Three-way exhaust catalyst. ADR 80/03 (J-NLT05) compliant. EEV compliant.

CLUTCH

- Fully automated hydraulically controlled wet clutch and fluid coupling with lock up.

TRANSMISSION

Isuzu MYY-6S

- 6 speed Automated Manual Transmission (AMT) with both fully automatic and clutchless manual operation modes.
- PTO provision on LHS of transmission case. PTO drive from counter gear.
- Gear ratios (:1)

1st	2nd	3rd	4th	5th	6th	Rev
5.979	3.434	1.862	1.297	1.000	0.750	5.701

AXLES

Front: Isuzu F031

- Reverse Elliot I-beam. 3,100 kg capacity.

Rear: Isuzu R066

- Full floating Banjo type. Four differential pinions. 6,600 kg capacity.
- Drive ratio: 5.125:1

SUSPENSION

Front:

- Single stage alloy steel multi leaf springs.
- Double acting hydraulic shock absorbers. Stabiliser bar.

Rear:

- Multi leaf main spring, multi leaf helper spring.
- Double acting hydraulic shock absorbers. Stabiliser bar.

BRAKES

- Auto adjusting front disc and rear drum brakes with dual circuit hydraulic control, vacuum/hydraulic pressure assistance and electronic brake force distribution (EBD).
- ABS.
- Front disc diameter: 310 mm
- Rear drum size: 320 x 100 mm
- 190 mm diameter drum park brake mounted on rear of transmission.
- Vacuum controlled exhaust brake.

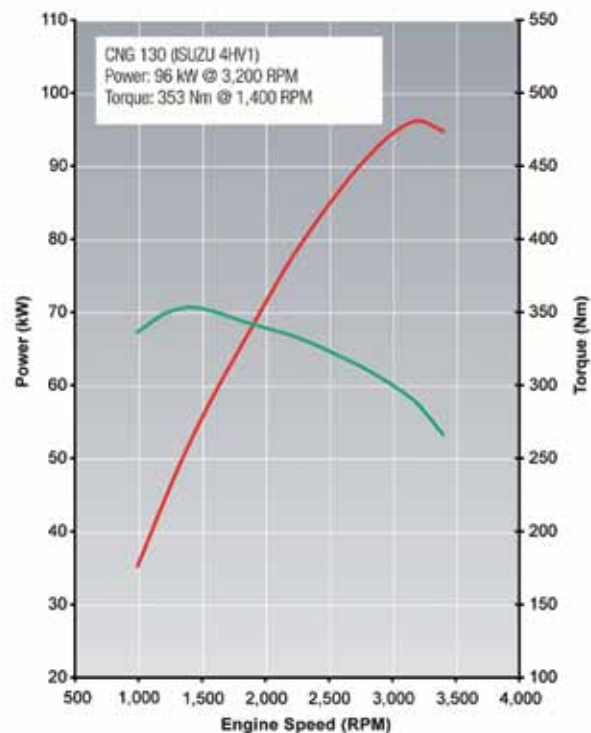

STEERING

- Power assisted recirculating ball steering.
- Gear ratio: 20.9:1
- Turns lock to lock: 5.4
- Maximum angle: 43° (inside wheel) / 33° (outside wheel)

WHEELS AND TYRES

- 17.5 x 6.00 six stud steel wheels.
- 205/75R 17.5 124/122M Michelin XZE2 Tubeless.
- Maximum tyre rating:
 - Steer axle: 3,200 kg
 - Drive axle: 6,000 kg
- 1 frame mounted spare wheel and tyre assembly.

CHASSIS FRAME

- Cold rivetted ladder frame. SAPH440 weldable steel sidemembers. Rivetless top flange.
- Frame dimensions:
 - Side rail (mm): 214 x 70 x 5.0
 - Rear frame width (mm): 750

FUEL SYSTEM

- 2 x steel CNG tanks with 150L liquid capacity each.
- Operating pressure: 20 MPa / 3,000 psi approx.

ELECTRICAL SYSTEM

- 24 volt electrical system.
- 80 amp alternator.
- 4.5 kW starter motor.
- 2 x 80D26L (630 CCA) batteries connected in series.

CABIN SPECIFICATIONS AND APPOINTMENTS

CAB EXTERIOR

- All steel construction. High tensile steel used for cab underframe. Manual cab tilt to 45° with torsion bar assistance.
- Complies with ECE-R29 cab strength standard.
- Liquid filled front and rear cab mounts.
- Heavy duty non slip entry steps.
- 90° opening internally reinforced front doors.
- Water spray suppression guards and front mudflaps.
- Laminated windscreen with shade band.
- Two speed windscreen wipers with intermittent wipe mode.
- Halogen multi-reflector headlamps incorporating turn signals. Additional door mounted side indicator lamps.
- Combination brake, turn, reverse and marker lamps, registration plate illumination lamps. Extended wiring harness. Reverse alarm.
- Roof-mounted clearance lamps.
- Heated and powered exterior main mirrors with flat glass and additional independently adjustable convex “spot” mirrors.
- Body coloured grille.
- Body coloured impact resisting polycarbonate bumper with steel backing frame.

CAB INTERIOR

- Contoured adjustable driver’s bucket seat.
- Front passenger bench seat with 2 seat capacity.
- 3-point lap sash seatbelts in all outboard seating positions. Driver and outboard front passenger seatbelts fitted with pretensioner. Centre seat lap belts.
- Driver and outboard front passenger airbag.
- Driver’s footrest.
- Door and roof pillar entry assist grips.
- Full interior trim, padded roof lining and vinyl floor covering. Driver and passenger windscreen header storage shelf.
- Tilt/Telescopic adjustable steering column, soft feel urethane steering wheel.
- Electric windows.
- Central locking with remote keyless entry.
- Twin cup holders. 24V cigarette lighter. Dashboard hook.
- Front door mounted storage pockets and driver’s side ashtray.
- Centre console box with storage tray. Fold down storage tray behind centre seat backrest.
- Fully integrated air conditioning and heater/demister with 4-speed fan and outlets for windscreen, side windows, face and floor.
- Fluorescent type interior lamp with On/Door/Off switch.
- 2 DIN, two speaker radio/CD multimedia unit with 4.8” LCD touch screen and Bluetooth. Provision for SD card, USB and 3.5 mm plug inputs.
- DIN sized compartment for storage or for CB radio installation.

DRIVER CONTROLS

- Key-operated engine start/stop and steering lock.
- Idle stop system on/off.
- AMT slow/fast gear engagement control, 1st gear start and normal/economy gear selection modes.
- **Left side combination stalk:** Windscreen wipers, washers and exhaust brake.
- **Right side combination stalk:** Turn signals and headlamps.

INSTRUMENTATION

- Electronically driven speedometer and tachometer. Digital odometer with integrated dual tripmeter. Engine coolant temperature and fuel level gauges.
- **Warning lamps:** Check engine, oil pressure, ABS, SRS airbag, alternator charge, service brakes, park brake, seatbelt unfastened, low fuel level, check AMT.
- **Indicator lamps:** Idle stop system, high beam, exhaust brake, turn signals, econo-mode, 1st gear start.
- Gear selection display.

OPTIONS AND GENUINE ACCESSORIES

Include the following (extra cost, request a brochure and further details from your Isuzu dealer):

- Satellite navigation - integrates with multimedia unit and includes NAVTEQ mapping.
- Up to three audio/visual reversing cameras - integrates with multimedia unit.
- Airbag compatible bullbar.
- Air deflector.



ISUZU
RELIABILITY IS EVERYTHING

WEIGHTS (kg)

Models	Ratings*		Loading Limit* (at ground)		Cab Chassis Mass #		
	GVM	GCM	Front	Rear	Front	Rear	Total
NPR 300 CNG	7,000	10,500	3,100	6,000	1,820	1,040	2,860

Maximum Gross Trailer Mass: 750 kg (unbraked), 3,500 kg (braked) * Vehicle ratings and front/rear weight limits are subject to government regulatory requirements and weight distribution analysis. Consult your Isuzu dealer to select the correct vehicle for your specific application. # Cab chassis only as supplied with full fuel.

DIMENSIONS (mm)

Models	WB	OAL	FOH	ROH	EA	CE	RT	ORT	CH	FFA (unladen)	RFA (unladen)	RFH (unladen)	Turn Circle (m)
													KERB TO KERB
NPR 300 CNG	3,395	6,098	1,110	1,593	2,710	4,415	1,525	1,985	2,300	635	760	805	11.8

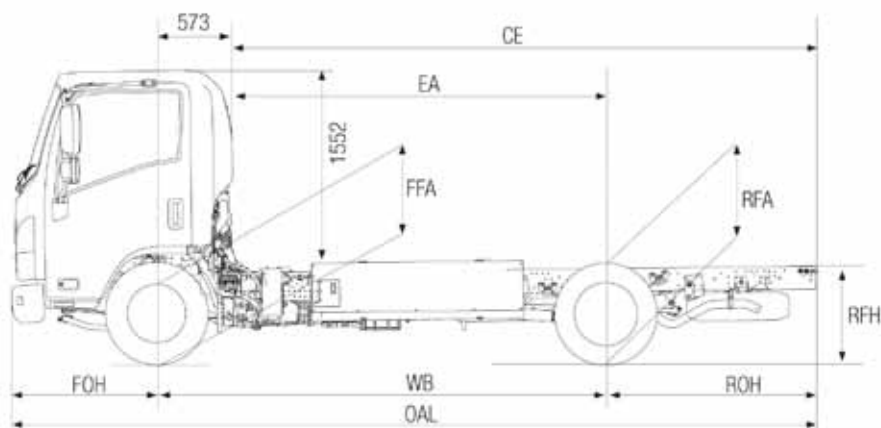
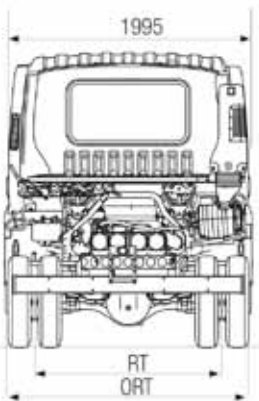
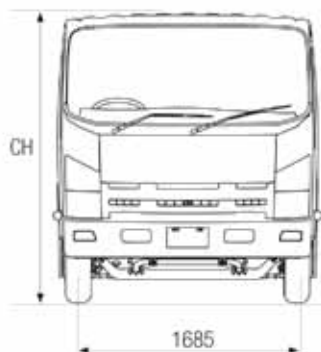

PERFORMANCE (calculated - typical paved road)

		Geared Speed* (top gear at peak power engine RPM)	Low Speed Gradeability (lowest forward gear assuming no wheel slip)	Engine Speed (top gear at 100km/h)
NPR 300 CNG	At 7000kg GVM	116km/h @ 3,200 RPM	38%	2,760 RPM

*Maximum speed achievable depends on vehicle frontal area as well as other factors. Consult your Isuzu dealer for more detailed information.

ISUZU WARRANTIES

STANDARD ¹		
New Vehicle	3 years • 100,000km • 2,000 hours	
Cab Perforation Corrosion	3 years • unlimited km's	
EXTENDED ²		
4 years, 200,000km	5 years • 250,000km	6 years • 300,000km
Isuzu Assist - 24 hour roadside assistance (3 years, unlimited km's)*		

ORDER CODES

Model	Code
NPR 300 CNG AMT	NH-NPRCL-D01

¹ Subject to the conditions outlined in the IAL New Vehicle Warranty, the Isuzu NPR models carry a standard factory warranty which covers the owner: (i) for the entire vehicle, for the first 36 months or 100,000 km or 2,000 hrs (whichever comes first), (ii) against cab perforation corrosion, for 36 months and unlimited kilometres. ² Extended Warranty as illustrated is available by purchase to cover the owner against the failure of original components, but may exclude some components and expendable items such as oil, filters, etc. Please consult with your Isuzu Dealer for full details obtained from a dedicated brochure available to customers. *Valid for three years from the date of new vehicle purchases.

ISUZU AUSTRALIA LIMITED ABN 97 006 962 572 ("IAL"). The information in this brochure was correct at time of printing, but all measurements, specifications and equipment are subject to change without notice. Some equipment may have been changed and/or is available at extra cost. IAL may make changes at any time without notice, in prices, colours, materials, equipment and models. IAL makes all reasonable attempts to ensure the availability of all vehicles and equipment. The information in this brochure is general in nature. Your Isuzu dealer can confirm all measurements, specifications and vehicle / equipment availability upon request.

TIC: Isuzu is a member of the Truck Industry Council - Safer Greener Essential.

August 2011. ARK0572



ISUZU
RELIABILITY IS EVERYTHING