

CHASSIS DIMENSIONS

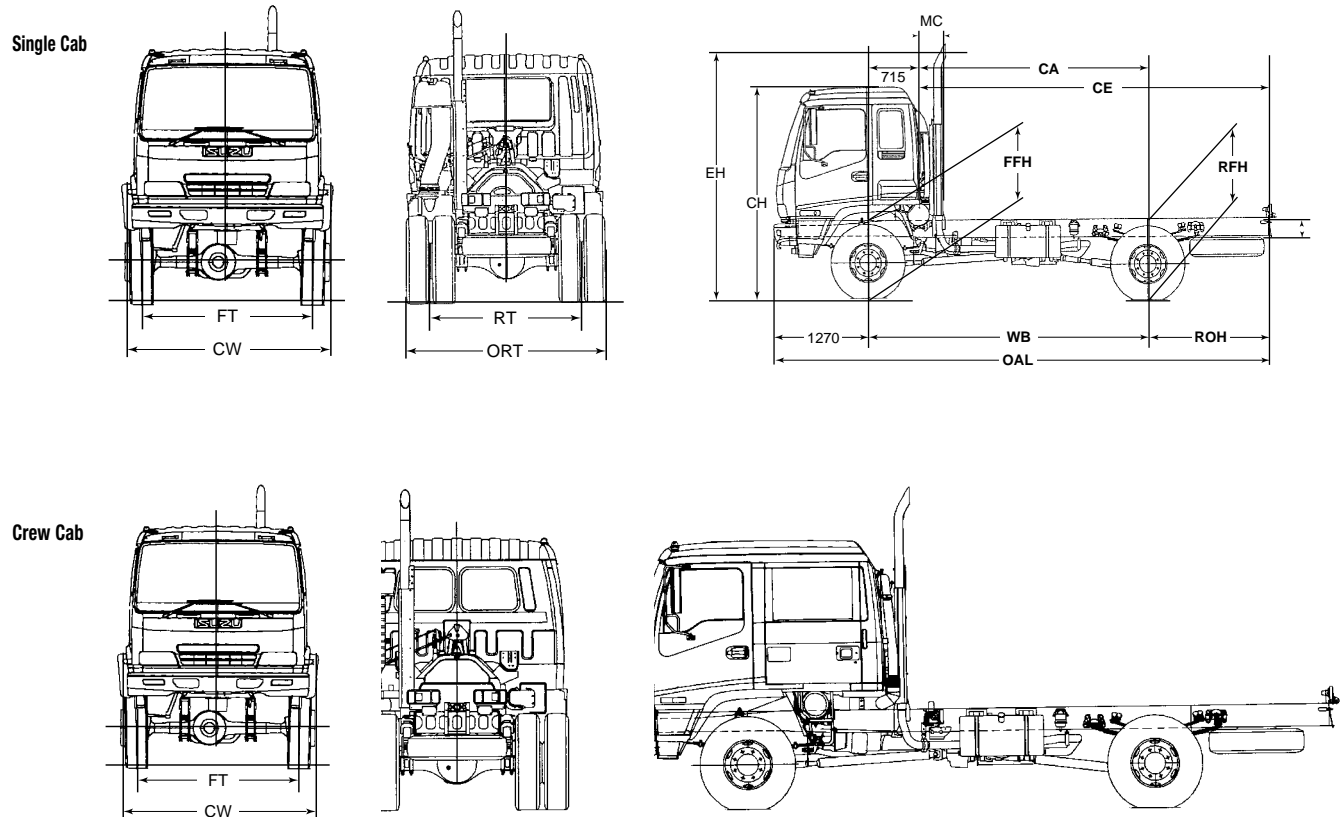

Dimensions in mm unless stated.

MODELS	WB	OAL	FOH	ROH	CA	CE	MC	FFH	RFH	Turning Circle (kerb to kerb) (m)	CW	CH	EH	FT	RT	ORT
FSS 550	3,700	6,575	1,270	1,605	2,985	4,590	290	950	910	15.2	2,200	2,700	3,285	1,770	1,680	2,195
FSS 550 CREW	4,200	7,270	1,270	1,800	2,795	4,595	290	950	910	17.2	2,200	2,700	3,290	1,770	1,680	2,195
FTS 750	4,250	7,420	1,270	1,900	3,535	5,435	270	1,060	1,040	17.7	2,400	2,885	3,380	1,950	1,790	2,360
FTS 750 CREW	4,250	7,420	1,270	1,900	2,845	4,745	270	1,060	1,040	17.7	2,400	2,860	3,380	1,950	1,790	2,360

ISUZU NEW TRUCK WARRANTIES

	STANDARD TRUCKPOWER WARRANTY*		TRUCKPOWER EXTENDED WARRANTY OPTIONS*		
NEW VEHICLE	2 years	100,000km	3 years / 150,000km	4 years / 200,000km	5 years / 250,000km
DRIVETRAIN	3 years	150,000km			
CAB CORROSION	3 years	unlimited			

* Subject to the conditions outlined in the I-GM New Vehicle Warranty, the Isuzu F Series models carry a standard factory warranty which covers the owner: (i) for the entire vehicle, for the first 24 months or 100,000km (whichever comes first) (ii) for the powertrain, which runs concurrently for 36 months or 150,000km (whichever comes first) (iii) against cab corrosion, for 36 months and unlimited kilometres.

A TruckPower Extended Warranty as illustrated is available by purchase to cover the owner against the failure of original components, but excludes some components and expendable items such as oil, filters, etc. Please consult with your Isuzu Dealer for full details obtainable from a dedicated brochure available to customers.

ISUZU-GENERAL MOTORS AUSTRALIA LTD A.C.N. 006 962 572. PLEASE NOTE: as the policy of I-GM is one of continual product improvement, all specifications and equipment are subject to change without notice. No I-GM dealer or other person is authorised or permitted to give or make any statement, assertion or undertaking in relation to the quality, performance, characteristics, descriptions or fitness for any purpose of any I-GM product or in connection with the supply of any I-GM product which is at variance with any written statement, assertion or undertaking on any of these subjects given or made by I-GM in its published sales literature, and the company accepts no liability for any such unauthorised action. I-GM has franchised dealers in many parts of Australia, for the sale of service, parts and the provision of service to the owners of I-GM products. Every endeavour is made to ensure that such dealers carry adequate stocks of service parts and are equipped to provide satisfactory service, but makes no promise, other than that contained in the I-GM new vehicle warranty, that such parts or service facilities will be available or available at any specific location or at any particular time. A word about this specification sheet. We have tried to make it as comprehensive and factual as possible. However, since the time of printing some of the information you will find here may have been updated. Also, some of the equipment shown or described through this specification sheet may have been changed and/or is available at extra cost. And the right is reserved to make changes at any time without notice, in prices, colours, materials, equipment and models. Your I-GM dealer has details and before ordering, you should ask him/her to bring you up to date.

RGS/IGM3129



F Series 4x4 MODELS

Cab/Chassis specification as at September 2000.

MODEL RANGE SUMMARY

MODELS	GVM (kg)	GCM (kg)	ENGINE	POWER (kW)	TORQUE (Nm)	TRANSMISSION	FRONT AXLE (kg)	REAR AXLE (kg)	BRAKES
FSS 550	10,000	15,000	SITEC 200	150/2,850	539/1,700	5sp/DD	3,900	6,500	A/H
FSS 550 CREW	10,000	15,000	SITEC 200	150/2,850	539/1,700	5sp/DD	3,900	6,500	A/H
FTS 750	13,000	18,000 Off Road 20,500 On Road	SITEC 200	150/2,850	539/1,700	7sp/OD	4,700	9,200	A/H
FTS 750 CREW	13,000	18,000 Off Road 20,500 On Road	SITEC 200	150/2,850	539/1,700	7sp/OD	4,700	9,200	A/H

* Note: All models available with 'Live Drive' flywheel Power Take Off unit.

CABIN SPECIFICATIONS AND APPOINTMENTS

CAB EXTERIOR

Standard Cab

- All steel cab with welded strengthening ribs and side door impact beams.
- Torsion bar assisted tilt to 45°.

Crew Cab

- All steel 4-door cab with welded strengthening ribs and side door impact beams.
- Electro-hydraulic tilt mechanism to 35°.

All

- Cation electrodeposition primer.
- Heavy duty bumper bar with step holes and footplate.
- Halogen headlamps, hinged for easy bulb replacement.
- Park lamps and cabin clearance lamps.
- Turn signal lamps in front bumper and on cab sides.
- 2 speed windscreen wiper / washer system with variable intermittent mode. Triple washer jets mounted on wiper arms.
- Tinted and laminated windscreen. Tinted and toughened side and rear glass.
- 'West Coast' type rear view mirrors. Additional, separately adjustable spotter mirror on both sides.
- Alloy, non-slip cabin entry steps. Steel rear entry steps on Crew Cab.
- Lift-up front panel for access to clutch and windscreen washer fluids without tilting the cabin. Engine and brake fluid check points at rear of cabin.

CAB INTERIOR

- Fully trimmed cab interior with formed roof lining. Overhead storage lockers. Driver and passenger sun visors.
- Isringhausen ISRI 6500/517 air suspension driver's seat with auto weight adjustment to 130kg. Height, rake and back rest recline adjustment. Pneumatic lumbar support.

- Outboard reclining passenger seat with premium cloth trim and under seat storage drawer. Folding centre seat back with lockable compartment and tray.
- Rear 4 person bench seat with premium cloth seat covering. (Crew Cab only)
- Full cab width, grab rail for rear passengers (Crew Cab only.)
- All outboard seating positions have lap/sash seat belts with emergency locking retractors. All inner seating positions have lap seat belts.
- Tilt/telescopic adjustable steering column with single release lever.
- Soft feel urethane steering wheel with zero offset to driver's seat.
- Easy entry grab handles on 'A' and 'B' pillars (front doors) and 'B' and 'C' pillars (rear doors). (Crew Cab only)
- Pull out drinks holder in centre fascia, cigarette lighter with ash trays in doors.
- Heater demister with 4 speed fan, 4 outlet vents to screen, 5 fascia outlets, 5 foot outlets, demister ducts to door glass.
- Optional fully integrated air conditioning.
- Eurovox AM/FM radio cassette with digital clock, dash mounted. Remote seek/volume and mute switch located on dash to right of steering wheel.
- Optional 6 stack CD player.
- DIN standard aperture in dash for CB radio.
- 12 Volt /100W cigarette lighter type electrical socket located in centre console.
- 24 Volt - 2 pin accessory plug in centre console.
- Park brake activation lever at left side of driver's seat.
- Combination passenger-side dash storage tray/fuse panel cover.
- Interior rear vision mirror.
- Passenger side assist grip.
- Driver's left foot rest.
- Business card clip.
- Elastic mesh pocket on driver's door.

CONTROLS

- Left side combination stalk switch for exhaust brake, windscreen wipers and washer, hazard lamps.
- Right side combination stalk switch for headlamps, high beam and turn signals.
- Engine idle speed adjust control.
- Key operation for engine start and stop, external engine crank switch for service when cab is tilted.
- 2 interior lamps, each with 3-way switch, activated by driver's front door.

INSTRUMENTATION

- GAUGES: Speedometer, odometer, trip meter and tachometer. Gauges for coolant temperature, fuel level and brake air pressure.
- WARNING LAMPS: With warning bulb check switch. Battery charge, oil pressure, low air pressure, brake system, stop and tail light failure.
- INDICATOR LAMPS: Turn signals, parking brake on, high beam on, exhaust brake engaged. Reversing lamp and beeper.

TOOLS

- Lockable tool box. 10,000kg capacity jack and wheel changing tools, tool kit.

ISUZU
RELIABILITY IS EVERYTHING

DRIVELINE SPECIFICATIONS

MODELS	FSS 550	FSS 550 PTO	FSS 550 CREW	FSS 550 CREW PTO	FTS 750	FTS 750 PTO	FTS 750 CREW	FTS 750 CREW PTO
GVM	10,000				13,000			
GCM	15,000				18,000 Off Road / 20,500 On Road			
Engine	SITEC 200							
Displacement	8.2 litres							
Bore/Stroke	115mm x 132mm							
Compression Ratio	18.5:1							
Power	150 kW @ 2,850 (ISO 1585)							
Torque	539 Nm @ 1,700 (ISO 1585)							
Cooling	<ul style="list-style-type: none"> • 6 blade plastic cooling fan 500mm diameter with thermatic fan clutch. • Corrugated fin radiator with fan shroud. Frontal area 3,820cm². • Coolant capacity 23.3 litres. 							
Air Intake	<ul style="list-style-type: none"> • Donaldson 11" two stage with vertical air intake stack and rain head. 							
Exhaust	<ul style="list-style-type: none"> • Horizontal exhaust muffler with vertical exhaust stack. • Exhaust brake, air controlled. 							
Fuel System	<ul style="list-style-type: none"> • In line plunger, Bosch 'ADS' type fuel injection pump with mechanical all speed governor. In line filter, see through water separator with drain cock. • Single fuel tank, capacity 180 litres. 							
Transmission	ISUZU MBJ-5J 5 Speed Direct Drive, constant mesh with synchromesh on gears 2-5 <ul style="list-style-type: none"> • Gear ratios: (: 1) 1st: 6.378 2nd: 3.627 3rd: 2.307 4th: 1.452 5th: 1.000 Rev: 6.59 • Maximum geared speed 100 km/h • 2 speed transfer case. 				ISUZU MLD 7Q 7 Speed Overdrive, constant mesh with synchromesh on gears 2-7 <ul style="list-style-type: none"> • Gear ratios: (: 1) 1st: 7.166 2nd: 4.526 3rd: 2.919 4th: 1.954 5th: 1.254 6th: 1.000 7th: 0.756 Rev: 7.276 • 2 speed transfer case. • Maximum geared speed 110 km/h • Electronically speed limited to 100km/h 			
Flywheel PTO Unit	-	<ul style="list-style-type: none"> • Drive ratio (PTO/Engine RPM): 0.7:1 • Max. output torque: 353Nm • Output flange rotates in same direction as engine 	-	<ul style="list-style-type: none"> • Drive ratio (PTO/Engine RPM): 0.7:1 • Max. output torque: 353Nm • Output flange rotates in same direction as engine 	-	<ul style="list-style-type: none"> • Drive ratio (PTO/Engine RPM): 0.7:1 • Max. output torque: 353Nm • Output flange rotates in same direction as engine 	-	<ul style="list-style-type: none"> • Drive ratio (PTO/Engine RPM): 0.7:1 • Max. output torque: 353Nm • Output flange rotates in same direction as engine
Clutch	<ul style="list-style-type: none"> • Hydraulic control dry single plate. 355mm (14") diameter. • Asbestos free lining material. Total lining area (both sides) 1,164cm². 				<ul style="list-style-type: none"> • Hydraulic control dry single plate. 355mm (14") diameter. • Asbestos free lining material. Total lining area (both sides) 1,164cm². 			
Axle – Front Capacity	ISUZU FD039 Capacity 3,900KG • Split type, fully floating with Birfield type steering ball joint. Ratio: 5.125:1. • Spiral bevel type ring gear, 365mm diameter. Oil capacity 3.2 litres.				ISUZU FD047 Capacity 4,700KG • Split type, fully floating with Birfield type steering ball joint. Ratio: 6.500:1. • Spiral bevel type ring gear, 365mm diameter. Oil capacity 5.5 litres.			
Axle – Rear Capacity	ISUZU R065 CAPACITY 6,500KG • Banjo type, fully floating, No-Spin differential lock. • Ratio: 5.125:1 • Hypoid type ring gear, 365mm diameter. Oil capacity 6.5 litres.				ISUZU R092 CAPACITY 9,200KG • Banjo type, fully floating, No-Spin differential lock. • Ratio: 6.500:1 • Hypoid type ring gear, 398mm diameter. Oil capacity 8.0 litres.			
Brakes	<ul style="list-style-type: none"> • Air over hydraulic, dual circuit, front two leading, rear dual two leading. Drum diameter front 400mm, rear 410mm. • Total swept area 5,853cm². • Air dryer. • All steel tubing. • Asbestos free lining material. • Spring park brake acting on rear wheels. 				<ul style="list-style-type: none"> • Air over hydraulic, dual circuit, front two leading, rear dual two leading. Drum diameter front 400mm, rear 410mm. • Total swept area 6,497cm². • Air dryer. • All steel tubing. • Asbestos free lining material. • Spring park brake acting on rear wheels. 			

CHASSIS SPECIFICATIONS

MODELS	FSS 550	FSS 550 PTO	FSS 550 CREW	FSS 550 CREW PTO	FTS 750	FTS 750 PTO	FTS 750 CREW	FTS 750 CREW PTO
GVM(kg)	10,000				13,000			
Tare – Total (kg)	3,950	4,000	4,240	4,290	4,655	4,705	4,910	4,960
– Front (kg)	2,505	2,545	2,710	2,750	2,900	2,940	3,070	3,110
– Rear (kg)	1,445	1,455	1,530	1,540	1,755	1,765	1,840	1,850
Frame	<ul style="list-style-type: none"> • Parallel rail, ladder type channel section, cold riveted. • Straight frame for easy body mounting. Frame width 840mm. • Side member dimensions: 229mm x 71mm x 8mm. • Material, SAPH440, weldable mild steel. 				<ul style="list-style-type: none"> • Parallel rail, ladder type channel section, cold riveted. • Straight frame for easy body mounting. Frame width 850mm. • Side member dimensions: 253mm x 80mm x 7.5mm. Frame reinforcement angle section: 240mm x 72.5mm x 4.5mm • Material, HT540A, weldable high tensile steel. 			
Suspension Front	<ul style="list-style-type: none"> • 1,350mm x 70mm x 12mm x 2 leaves. • 1,350mm x 70mm x 14mm x 2 leaves. • 1,350mm x 70mm x 16mm x 1 leaf. 				<ul style="list-style-type: none"> • 1,470mm x 80mm x 12mm x 3 leaves. • 1,470mm x 80mm x 13mm x 5 leaves. • 1,470mm x 80mm x 18mm x 1 leaf. 			
Suspension Rear	<ul style="list-style-type: none"> • Main: 1,300mm x 70mm x 11mm x 3 leaves • 1,300mm x 70mm x 12mm x 4 leaves. • Aux: 850mm x 70mm x 10mm x 3 leaves • 850mm x 70mm x 11mm x 4 leaves 				<ul style="list-style-type: none"> • Main: 1,420mm x 80mm x 12mm x 1 leaf • 1,420mm x 80mm x 13mm x 6 leaves. • Aux: 1,000mm x 80mm x 12mm x 9 leaves. 			
Steering	<ul style="list-style-type: none"> • Fully integral, power assisted, recirculating ball type. • Gear ratio 16.1 ~18.8 : 1. Turns lock to lock 2.8. • Gear driven vane type oil pump. Oil capacity 1.5 litres. 				<ul style="list-style-type: none"> • Fully integral, power assisted, recirculating ball type. • Gear ratio 22.4 ~18.8 : 1. Turns lock to lock 3.5. • Gear driven vane type oil pump. Oil capacity 2.5 litres. 			
Wheels	<ul style="list-style-type: none"> • 6.50T x 20, 8 stud disc wheels. • Number of wheels and tyres 7, including spare. • Winch type spare wheel carrier. 				<ul style="list-style-type: none"> • 7.00T x 20, 8 stud disc wheels. • Number of wheels and tyres 7, including spare. • Winch type spare wheel carrier. 			
Tyres	8.25R20 133/131K Tubed Type radial ply tyres front and rear. • Type: Michelin XZY • Load & Speed Ratings per tyre: 2,060kg (Single) / 1,950kg (Dual) / 110km/h.				9.00R20 140/137K Tubed Type radial ply tyres front and rear. • Type: Michelin XZY • Load & Speed Ratings per tyre: 2,500kg (Single) / 2,300kg (Dual) / 110km/h.			
Electrical System	<ul style="list-style-type: none"> • Batteries - 2 x 12 volt / 65 amp/h, negative earth. • Alternator - 24 volt / 60 amp (1.5kW output). • Starter motor - 24 volt / 4.5kW. • Rear stop and tail lamps and licence plate lamp with long leads for variable body mounting. 				<ul style="list-style-type: none"> • Batteries - 2 x 12 volt / 65 amp/h, negative earth. • Alternator - 24 volt / 60 amp (1.5kW output). • Starter motor - 24 volt / 4.5kW. • Rear stop and tail lamps and licence plate lamp with long leads for variable body mounting. 			