

ISUZU

SPECIFICATIONS

NEW
NEW GENERATION ISUZU
GEN

FSD 700-S

FSD 850-S



FSD 700-S pictured

AUSTRALIA'S TOP SELLING TRUCK BRAND SINCE 1989. Truck tracker 2007.

AT A GLANCE

GVM	12,000 / 14,000 kg
GCM	18,000 / 20,000 kg
Power	191 kW @ 2,400 rpm
Torque	761 Nm @ 1,450 - 2,400 rpm

UPGRADE OPTIONS

Premium Pack:

- Automated Manual Transmission (AMT)
- Instrument panel multi-information display
- Cruise control
- Auto control for airconditioning

ADVANCED TECHNOLOGY

- Driver airbag with seatbelt pretensioner
- Anti-lock Braking System (ABS)
- Anti Skid Regulator (ASR)
- Hill Start Aid (HSA)
- Electric mirrors
- Front and rear stabiliser bars
- ISRI 6860 seat with integrated seatbelt
- Electronically controlled 4-bag air rear suspension

RELIABILITY IS EVERYTHING **ISUZU**

Driveline & Chassis Specifications

ENGINE: SITEC SERIES II 255 (ISUZU 6HK1-TCC)

- Type:** 6 cylinder 24 valve SOHC
Displacement: 7,790 cc
Compression Ratio: 17.5:1
Bore x Stroke: 115 mm x 125 mm
Max power (DIN-NET): 191 kW (256 HP) @ 2,400 RPM
 (JIS Gross): 198 kW (265 HP) @ 2,400 RPM
Max torque (DIN-NET): 761 Nm (561 lb.ft) @ 1,450 - 2,400 RPM
 (JIS Gross): 788 Nm (581 lb.ft) @ 1,450 - 2,400 RPM
Induction system: Electronically controlled variable nozzle turbocharger with air-to-air intercooler.
Fuel injection: Direct injection high pressure common rail system.
Emission control system: Two-stage electronically controlled cooled EGR with exhaust Diesel Particulate Diffuser (DPD). ADR 80/02 (Euro IV) compliant.

CLUTCH

- MW model:**
- Air assisted hydraulic control. Single plate 381 mm diameter.
 - Total lining area: 1,363 cm²
- Premium Pack:**
- Fully automated hydraulically controlled wet clutch and fluid coupling with lock up.

TRANSMISSION

ISUZU MZX-6P (except MW model)

- 6 speed Automated Manual Transmission (AMT) with both fully automatic and clutchless manual operation modes.
- Synchromesh on gears 2-6. Triple cone synchromesh on 2nd and 3rd gears. Integral oil pump provides full pressure lubrication.
- PTO provision on LHS of transmission case. PTO drive from counter gear.
- Gear ratios (: 1)

1st	2nd	3rd	4th	5th	6th	Rev
6.615	4.095	2.358	1.531	1.000	0.722	6.615

ISUZU MLD-6W (MW model)

- 6 speed manual with air assisted shift.
- Synchromesh on gears 2-6.
- PTO provision on LHS of transmission case. PTO drive from counter gear.
- Gear ratios (: 1)

1st	2nd	3rd	4th	5th	6th	Rev
6.120	4.244	2.580	1.540	1.000	0.763	6.525

AXLES

- Front:** Isuzu F050
- Reverse Elliot I-beam. 5,000 kg capacity.
- Rear:** Isuzu R090
- Full floating Banjo type. 9,000 kg capacity.
 - Drive ratio: 4.555:1 (except MW model), 4.875:1 (MW model)

SUSPENSION

- Front:**
- Single stage alloy steel taper leaf springs.
 - Double acting hydraulic shock absorbers. Stabiliser bar.

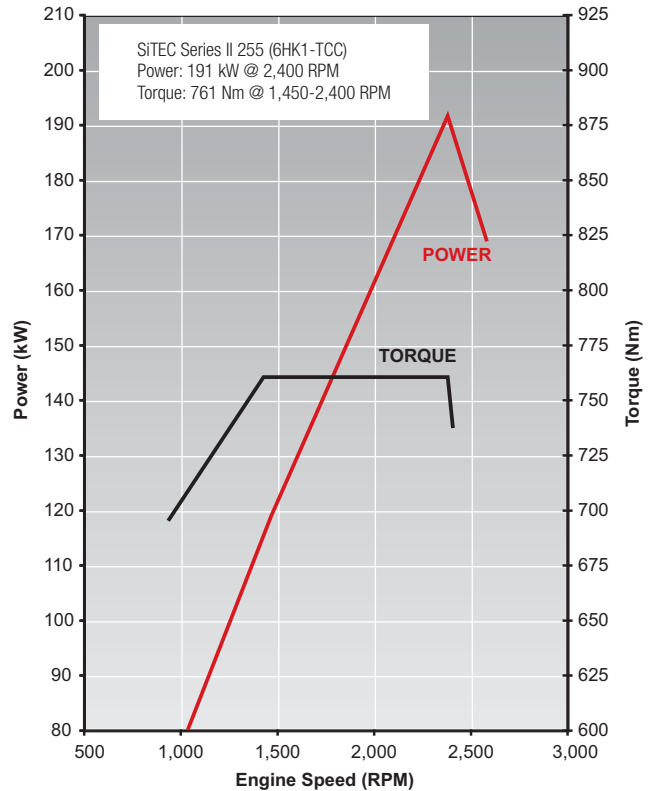

Rear:

- Isuzu 4-bag electronically controlled air suspension system.
- Double acting hydraulic shock absorbers. Stabiliser bar.

BRAKES

- Dual circuit air over hydraulic front and rear drum brakes.
- ABS.
- ASR traction control.
- Hill Start Aid (HSA).
- Front drum size: 370 x 150 mm
- Rear drum size: 370 x 150 mm
- Spring park brake.
- Air controlled exhaust brake.
- Air dryer.

STEERING

- Power assisted recirculating ball steering.
- Gear ratio: 16:1 - 18.8:1
- Turns lock to lock: 4.1
- Maximum angle: 44° (inside wheel) / 34° (outside wheel)

WHEELS AND TYRES

- 19.5 x 6.75 eight stud steel wheels.
- 265/70R19.5 140/138M Michelin XZE2 Tubeless.
- Maximum tyre rating:
 - Steer axle: 5,000 kg
 - Drive axle: 9,440 kg
- Spare wheel and tyre assembly with winch type carrier.

CHASSIS FRAME

- Cold rivetted ladder frame with parallel side rails. HT540A high tensile weldable steel sidemembers.
- Frame dimensions:
 - Side rail (mm): 225 x 70 x 6.0
 - Rear frame width (mm): 840

FUEL TANK

- Frame mounted 200L steel fuel tank.
- Lockable fuel cap.

ELECTRICAL SYSTEM

- 24 volt electrical system.
- 60 amp alternator.
- 24 Volt, 4.5 kW starter motor.
- 2 x 80D26L (630 CCA) batteries connected in series.

Cabin Specifications and Appointments

CAB EXTERIOR

- All steel construction. High tensile steel used for cab underframe. Manual cab tilt to 45° with torsion bar assistance.
- Liquid filled front and rear cab mounts.
- Heavy duty non slip entry steps.
- 90° opening internally reinforced front doors.
- Water spray suppression guards and front mudflaps.
- Laminated windscreen with shade band.
- Two speed windscreen wipers, with intermittent wipe mode.
- Halogen multi-reflector headlamps incorporating turn signals. Additional door mounted side indicator lamps.
- Combination brake, turn, reverse and marker lamps, registration plate illumination lamps. Extended wiring harness. Reverse alarm.
- Roof-mounted clearance lamps.
- Heated and powered exterior main mirrors with flat glass and additional powered convex "spot" mirrors.
- **Except Premium Pack:** Body coloured grille. **Premium Pack:** Chrome grille.
- Body coloured steel air dam bumper with front foglamps.

CAB INTERIOR

- Isri 6860 air suspension driver's seat with pneumatic lumbar support, height, rake and automatic weight adjustment.
- Front passenger adjustable bucket seat and front centre seat with folding seat back.
- 3-point lap sash seatbelts in all outboard seating positions. Driver seatbelt with pre-tensioner integrated with driver seat. Centre seat lap belts.
- Driver airbag.
- **Premium Pack:** Driver's footrest.
- Door and roof pillar entry assist grips.
- Full interior trim, padded roof lining and vinyl floor covering. Driver and passenger windscreen header storage shelf.
- Tilt/Telescopic adjustable steering column, soft feel urethane steering wheel.
- Electric windows.
- Central locking with remote keyless entry and immobiliser.
- Twin cup holders. 24V cigarette lighter. Dashboard hook.
- Front door mounted storage pockets and driver's side ashtray.
- Centre console box with storage tray. Fold down storage tray behind centre seat backrest.
- Front passenger glovebox.

- Fully integrated air conditioning and heater/demister with 4-speed fan and outlets for windscreen, side windows, face and floor. **Except Premium Pack:** Manual control. **Premium Pack:** Auto control.
- Fluorescent type interior lamp with On/Door/Off switch.
- 2 DIN, two speaker radio/CD multimedia unit.
- DIN sized compartment for storage or for CB radio installation.

DRIVER CONTROLS

- Key-operated engine start/stop and steering lock. Engine idle speed control.
- HSA slow/fast engagement control and on/off switch.
- ASR on/off.
- DPD regeneration.
- Hand held pendant for rear suspension raise and lower.
- **Premium Pack:** AMT slow/fast gear engagement control, 1st gear start and normal/economy gear selection modes.
- **Left side combination stalk:** Windscreen wipers, washers and exhaust brake.
- **Right side combination stalk:** Turn signals, headlamps, **Premium Pack:** Cruise control.

INSTRUMENTATION

- Electronically driven speedometer and tachometer. Digital odometer with integrated dual tripmeter. Engine coolant temperature, fuel level and air pressure gauges.
- **Warning lamps:** Check engine, oil pressure, ABS, SRS airbag, alternator charge, service brakes, park brake, seat belt unfastened, low air pressure, air suspension failure, low fuel level, cab lock. **Premium Pack:** Check AMT.
- **Indicator lamps:** HSA, warm up system, high beam, ASR, DPD status, exhaust brake, turn signals. **Premium Pack:** Cruise control, econo-mode, 1st gear start.
- **Premium Pack:** Gear selection display.
- **Premium Pack:** Multi-information display. Shows service interval, instantaneous and average fuel consumption, DPD bar chart, hourmeter, voltmeter, time/day/date and includes 40-120 km/h adjustable vehicle speed warning.

OPTIONS AND GENUINE ACCESSORIES

Include the following (extra cost, check with dealer for availability):

- Module for Bluetooth/iPod input/SD card reader.
- Module for Bluetooth/iPod input/SD card reader/satellite navigation (includes NAVTEQ mapping).
- Up to two reversing cameras.
- Airbag compatible bullbars.
- Cloth seat covers.

Weights (kg)

Models	Ratings*		Loading Limit* (at ground)		Cab Chassis Mass#		
	GVM	GCM	Front	Rear	Front	Rear	Total
FSD 700-S / 850-S Long MW	12,000 / 14,000	18,000 / 20,000	5,000	9,000	2,485	1,520	4,005
FSD 700-S / 850-S Long Premium	12,000 / 14,000	18,000 / 20,000	5,000	9,000	2,475	1,515	3,990

* Vehicle ratings and front/rear weight limits are subject to government regulatory requirements and weight distribution analysis. Consult your Isuzu dealer to select the correct vehicle for your specific application.

Cab chassis only as supplied and including 10 litres of fuel.

Dimensions (mm)

Models	WB	OAL	FOH	ROH	EA	CE	RT	ORT	CH	FFA (unladen)	RFA (unladen)	RFH (unladen)	Turn Circle (m)
													KERB TO KERB
FSD 700-S / 850-S Long	5,560	9,155	1,170	2,425	4,575	7,090	1,660	2,215	2,590	745	790	790	19.9

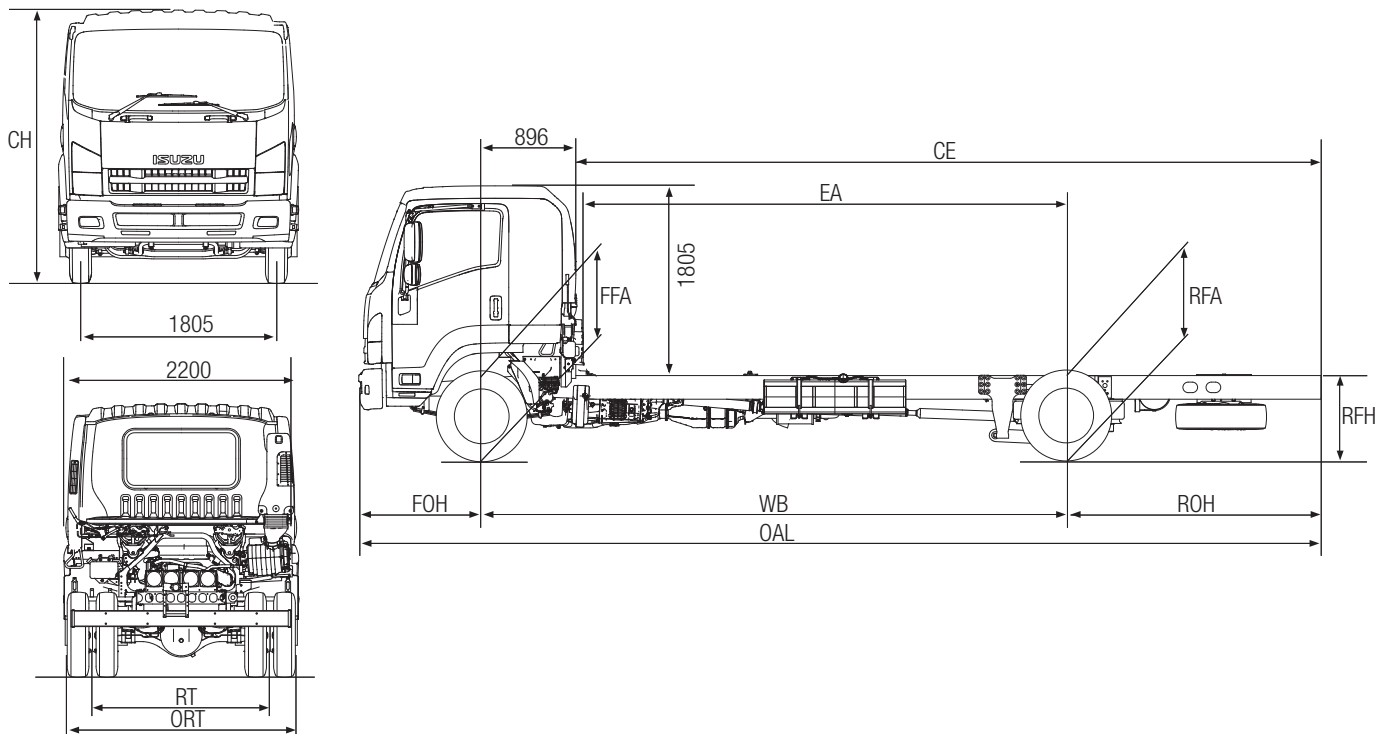

Performance (calculated - typical paved road)

Model	Weight	Geared Speed* (top gear at peak power engine RPM)	Low Speed Gradeability (lowest forward gear assuming no wheel slip)	Engine Speed (top gear at 100 km/h)
FSD 700-S MW	At 12,000 kg GVM	102 km/h @ 2,400 RPM	41%	2,345 RPM
FSD 700-S Premium Pack	At 12,000 kg GVM	116 km/h @ 2,400 RPM	41%	2,070 RPM
FSD 850-S MW	At 14,000 kg GVM	102 km/h @ 2,400 RPM	35%	2,345 RPM
FSD 850-S Premium Pack	At 14,000 kg GVM	116 km/h @ 2,400 RPM	35%	2,070 RPM

* Maximum speed achievable depends on vehicle frontal area as well as other factors. Consult your Isuzu dealer for more detailed information. FSR/FSD 850-S models speed limited to 100km/h.

Isuzu Warranties

STANDARD ¹		
New Vehicle	3 years 150,000 km 2,500 hrs	
Cab Perforation Corrosion	3 years Unlimited km	
EXTENDED ²		
4 years 250,000 km	5 years 300,000 km	6 years 350,000 km

Order Codes

Model	Code
FSD 700-S / 850-S Long MW	FH-FSDCH-X01
FSD 700-S / 850-S Long Premium	FH-FSDDH-Z01

¹ Subject to the conditions outlined in the IAL New Vehicle Warranty, the Isuzu FSD models carry a standard factory warranty which covers the owner: (i) for the entire vehicle, for the first 36 months or 150,000 km or 2,500 hrs (whichever comes first), (ii) against cab perforation corrosion, for 36 months and unlimited kilometres. ² Extended Warranty as illustrated is available by purchase to cover the owner against the failure of original components, but may exclude some components and expendable items such as oil, filters, etc. Please consult with your Isuzu Dealer for full details obtained from a dedicated brochure available to customers.

ISUZU AUSTRALIA LIMITED ABN 97 006 962 572 ("IAL"). The information in this brochure was correct at time of printing, but all measurements, specifications and equipment are subject to change without notice. Some equipment may have been changed and/or is available at extra cost. IAL may make changes at any time without notice, in prices, colours, materials, equipment and models. IAL makes all reasonable attempts to ensure the availability of all vehicles and equipment. The information in this brochure is general in nature. Your Isuzu dealer can confirm all measurements, specifications and vehicle / equipment availability upon request.

July 2008. ARK0332