

ISUZU FVR 950 HD FVD 950 HD



ISUZU
RELIABILITY IS EVERYTHING

AT A GLANCE

GVM	16,500 kg
GCM	32,000 kg
Engine Type	Isuzu SiTEC 275
Displacement	9.8 L
Power	206 kW @ 2,000 rpm
Torque	1,030 Nm @ 1,400 rpm
Wheelbase	5,550 - 6,050 mm

DRIVELINE & CHASSIS SPECIFICATIONS

ENGINE: SITEC 275 (ISUZU 6SD1-TC)

Type: 6 cylinder, 4 stroke, SOHC, direct injection diesel.
Variable Geometry Turbocharger (VGT) and air-to-air intercooler. Adjustable roller type rocker arms.

Displacement: 9,839 cc

Compression Ratio: 16.0:1

Bore x Stroke: 120 x 145 mm

Max power (DIN NET): 206 kW @ 2,000 RPM

Max torque (DIN NET): 1030 Nm @ 1,400 RPM

Emissions Standard: ADR 80/00 (Euro-III)

- Plate type oil cooler. 28.4 L oil capacity. Separate full flow main filter and bypass oil filter.

COOLING SYSTEM

- 6 blade, 600 mm diameter cooling fan with thermostatically controlled viscous clutch. Dual drive belts. Radiator frontal area: 5,088 cm². 29 L coolant capacity.

AIR INTAKE SYSTEM

- Vertical air intake mounted on back of cab. Two stage Donaldson air cleaner with 280 x 380 mm main element and 160 x 350 mm secondary element.
- 610 x 540 mm air-to-air intercooler.

FUEL SYSTEM

- Denso common rail fuel injection. Separate fuel filter and water separator.
- 400 L aluminium tank (manual models).
180 L steel tank (automatic models).

CLUTCH

- Air assisted hydraulic control.
Single plate 381 mm diameter.
Asbestos free cerametallic lining material.
Total lining area: 1,363 cm²

TRANSMISSION

EATON FS-8209A BBE 9 Speed manual (Long/Custom Long)

- 9 forward speeds. Direct drive.
 - Syncromesh on gears 1-8. Repeat 'H' shift pattern.
 - 8.5 L oil capacity.
 - Two SAE PTO openings on LHS of transmission case.
 - Gear ratios (: 1)
- | | | | | | | | | | |
|-------|------|------|------|------|------|------|------|------|-------|
| Low | 1st | 2nd | 3rd | 4th | 5th | 6th | 7th | 8th | Rev |
| 12.64 | 8.81 | 6.55 | 4.77 | 3.55 | 2.48 | 1.85 | 1.34 | 1.00 | 13.17 |

ALLISON MD 3060P 6 Speed automatic (Auto model)

- Electronically controlled automatic transmission with adaptive shift. 6 forward speeds including overdrive.
 - 27 L oil capacity.
 - SAE PTO openings on LHS & RHS of transmission bell housing.
 - Gear ratios (: 1)
- | | | | | | | |
|------|------|------|------|------|------|------|
| 1st | 2nd | 3rd | 4th | 5th | 6th | Rev |
| 3.49 | 1.86 | 1.41 | 1.00 | 0.75 | 0.65 | 5.03 |

AXLES

FRONT: MERITOR FG941

- Reverse Elliot I-beam. 6,600 kg capacity.
- Oil bath lubricated front wheel hubs, see through oil level indicator.

REAR: MERITOR RS-23-161G

- Full floating Banjo type. 10,400 kg capacity.
- Drive ratio: Manual: 3.909:1, Auto: 5.625:1
- Cross locks available as optional fitment.

SITEC 275

Maximum Power : 206 kW @ 2,000 RPM

Maximum Torque : 1,030 Nm @ 1,400 RPM

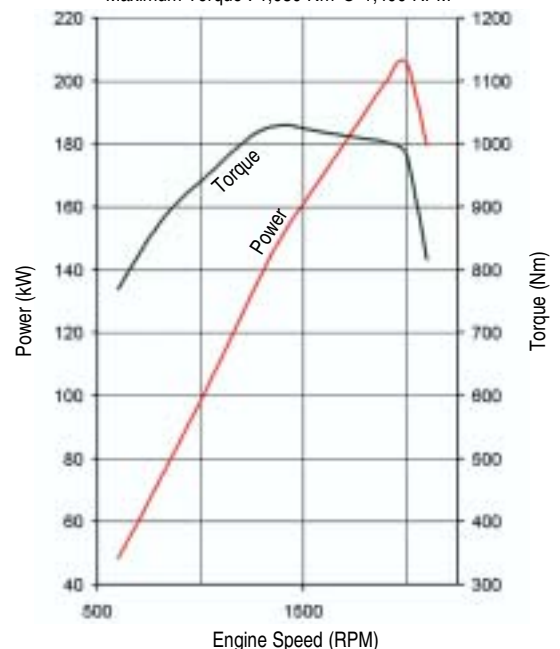

ISUZU SITEC 275 (6SD1-TC) ENGINE PERFORMANCE CHART

SUSPENSION

FRONT

- Single stage, alloy steel, taper leaf springs. Fully wrapped eye with greasable shackles.
- Nominal size: 1,600 x 80 mm
- Total spring capacity (at ground): 6,670 kg
- Double acting, hydraulic shock absorbers. Stabiliser bar.

REAR FVR 950 HD

- Two stage, alloy steel, multi-leaf springs. Fully wrapped eye with greasable shackles.
- Nominal size: 1,420 x 100 mm
- Total spring capacity (at ground): 11,300 kg
- Stabiliser bar.

REAR FVD 950 HD

- Hendrickson HAS230 airbag.
- Two rolling lobe air springs.
- Total spring capacity (at ground): 11,120 kg
- Outboard mounted, double acting shock absorbers.
- Height control valve.

BRAKES

- Meritor 'Q-Plus' Full air 'S-cam' brakes with automatic slack adjusters.
- Front drum diameter: 419 mm
- Rear drum diameter: 419 mm
- Swept area: 8,030 cm²
- Asbestos free lining material.
- Spring type parking brake acting on rear wheels.
- Air controlled exhaust brake.
- 78.5 L total air reservoir capacity.
- Air dryer.

STEERING

- Power assisted recirculating ball steering.
- 22.4:1 gear ratio.
- 5.4 turns lock to lock.
- 45° wheel cut angle (inside wheel).

WHEELS AND TYRES

- 8.25 x 22.5 Ten stud ISO standard disc wheels.
- 11R22.5 148/145L Michelin XDE2 Tubeless tyres (drive axle).
11R22.5 148/145L Michelin XZE2 Tubeless tyres (steer axle).
- Maximum tyre rating: 3,150 kg per tyre (single tyres).
2,900 kg per tyre (dual tyres).
- Frame mounted winch type spare wheel carrier (except auto). Spare wheel and XZE2 tyre assembly supplied.

AXLE LOAD SUMMARY

FVR 950 HD	FRONT	REAR
Axle Capacity (kg):	6,600	10,400
Spring Capacity (kg):	6,670	11,300
Tyre Capacity (kg):	6,300	11,600
Legal Limit (kg):	6,000	9,000
Limit (kg):	6,000	9,000

FVD 950 HD

	FRONT	REAR
Axle Capacity (kg):	6,600	10,400
Spring Capacity (kg):	6,670	11,120
Tyre Capacity (kg):	6,300	11,600
Legal Limit (kg):	6,000	10,000
Limit (kg):	6,000	10,000

Note: Vehicle loading limit is determined by the combination of axle loading limit, GVM and GCM limit, and government regulatory requirements. Consult your Isuzu dealer to select the correct vehicle for your specific application.

CHASSIS FRAME

- Cold riveted ladder frame with parallel side rails.
- Frame material: **Long** SAPH440 **Auto** HT540A
- Side rail (mm): 258 x 85 x 10 254 x 85 x 8
- Rear frame width (mm): 850 850
- Frame reinforcement section.
- Front and rear tow hooks.

ELECTRICAL SYSTEM

- 24 Volt electrical system.
- 24 Volt, 60 Amp alternator.
- 24 Volt, 5.5 kW starter motor.
- 2 x 75D23R (520CCA) batteries connected in series.

CABIN SPECIFICATIONS AND APPOINTMENTS

CAB EXTERIOR

- All steel cab, side door impact protection beams. Outer body panels galvanised, corrosion resistant primer treated cab.
- Manual cab tilt to 45°. Access to fluid checkpoints without tilting cab. Lift up front access panel for clutch, windscreen washer fluids and cab air filter screen. Four point silicone filled rubber cab mounting.
- Body coloured steel front bumper with step holes and footplate.
- 90° opening internally reinforced door. Heavy duty aluminium non slip entry steps.
- Tinted, laminated windscreen. 2 speed windscreen wiper system, variable intermittent wipe mode, triple washer jets.
- Halogen headlamps. Park lamps and roof-mounted clearance lamps.
- Combination brake, turn, reverse and marker lamps, registration plate illumination lamps. Extended wiring harness. Reverse alarm.
- "West Coast" type rear view mirrors. Large flat mirror glass with additional, independently adjustable convex "spot" mirror on both sides.

CAB INTERIOR

- Isringhausen ISRI 6500/517 air suspension driver's seat, auto weight adjustment to 130 kg. Height, rake and backrest recline adjustment. Pneumatic lumbar support. Reclining passenger bucket seat. Centre seat with folding seat back (manual models only).
- 3-point, lap sash seatbelts with emergency locking belt retractors in all outboard seating positions.
- Centre lap seatbelt (manual models only).
- "A" pillar entry assist grips. Interior lamp with On/Door/Off switch activated by either door.
- Full interior panel trim, padded roof lining, vinyl floor mats. Windscreen header storage shelf. DIN sized aperture in dash for CB. Overhead console fitted with harness for CB.
- Tilt/Telescopic adjustable steering column, soft feel urethane steering wheel.
- 12 Volt, 100 Watt and 24 Volt, 2 pin accessory sockets located in centre console.
- Electric windows.

- Central locking with remote keyless entry.
- Centre facia pullout drinks holder. Lockable storage compartment on centre seat back (manual models), in centre console (automatic model).
- Heater/Demister with 4-speed fan and outlets for windscreen, side windows, face and floor.
- Standard fully integrated air conditioning.
- Two speaker Eurovox Radio/CD player with digital anti skip memory.
- Remote seek/volume and mute switch located on dash to right of steering wheel.
- Optional 10 stack CD player.

DRIVER CONTROLS

- Key-operated engine start/stop and steering lock. Electronic throttle control. Engine idle speed control.
- Left side combination stalk: Windscreen wipers, washers, exhaust brake and hazard lights.
- Right side combination stalk: Turn signals and headlamps.
- Pushbutton gear selection (automatic model).

INSTRUMENTATION

- Gauges: Electronically driven speedometer, odometer, tripmeter, tachometer. Gauges for coolant temperature and brake air pressure.
- Warning lamps: Warning bulb check switch. Battery charge, brake system, engine malfunction, oil pressure, stop and tail lamp failure.
- Indicator lamps: Turn signals, parking brake, high beam, exhaust brake engaged.

CUSTOM CAB MODEL

FEATURES REPLACING OR ADDITIONAL TO STANDARD CAB FEATURES

- Chrome radiator grille and headlamp surrounds.
- Gold "Custom" badging and emblem. Gold ISUZU badge.
- Fluorescent interior lamp.
- Woodgrain instrument panel.
- Auto sensor headlight switch.
- Carpet floor covering.

FVR 950 HD Long

8FS02-6E0

FVD 950 HD Long / Custom Long / Auto

8FS02-6E1 8FS02-6E4 8FS02-6F1

PERFORMANCE (Calculated)

	FVR 950 HD LONG	FVD 950 HD LONG	FVD 950 HD AUTO
Max Geared speed:	105* km/h @ 2,100 rpm	105* km/h @ 2,100 rpm	112* km/h @ 2,100 rpm
Gradeability (lowest gear):	60% at 15,000 kg GVM	56% at 16,000 kg GVM	45% at 16,000 kg GVM
Gradeability (top gear at 100 km/h):	1.6% (2.5 x 3.4 m van body at 15,000 kg GVM)	1.4% (2.5 x 3.4 m van body at 16,000 kg GVM)	1.2% (2.5 x 3.4 m van body at 16,000 kg GVM)
Engine speed (top gear at 100 km/h):	2,000 rpm	2,000 rpm	1,870 rpm

Performance figures quoted are representative only and based on typical dimensions, body styles and weights. Please consult your Isuzu dealer for an estimation based on your specific application. * Road speed limited to 100 km/h

MODEL RATINGS AND DIMENSIONS

MODELS	RATINGS (kg)		TARE MASS [#] (kg)			DIMENSIONS (mm)													TURN CIRCLE KERB TO KERB
	GVM	GCM	TOTAL	FRONT	REAR	WB	OAL	FOH	ROH	CA	CE	RT	ORT	CH	CW	FFH UNLADEN	RFH UNLADEN		
FVR 950 Long	16,500	32,000	5,295	3,175	2,120	6,050	10,000	1,250	2,700	5,340	8,040	1,840	2,450	2,760	2,440	955	1,020	20.1 m	
FVD 950 Long	16,500	32,000	5,175	3,145	2,030	6,050	10,000	1,250	2,700	5,340	8,040	1,840	2,450	2,760	2,440	955	965	20.1 m	
FVD 950 Auto	16,500	32,000	5,050	3,035	2,015	5,550	9,250	1,250	2,450	4,840	7,290	1,840	2,450	2,760	2,440	955	965	18.7 m	

Estimated mass of cab/chassis with oil, water and fuel tank containing 10 litres of fuel and excluding spare wheel (95 kg) and tools (30 kg).

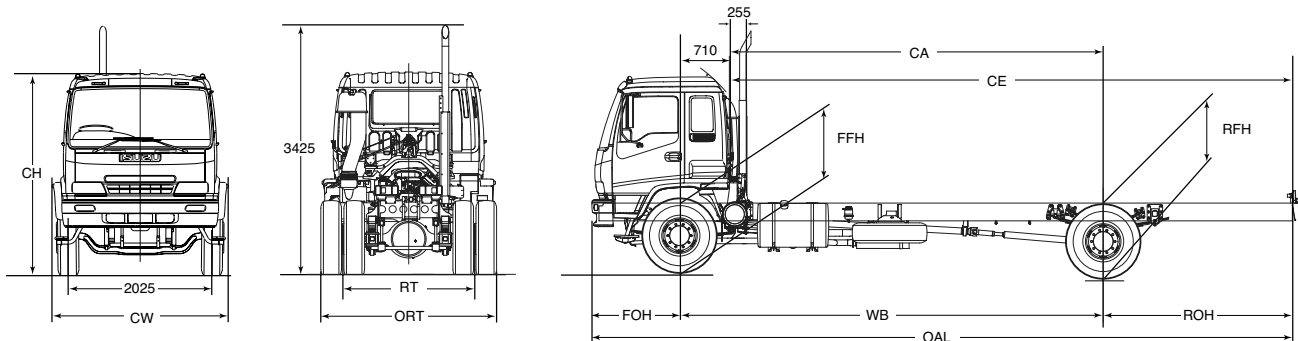

For further information regarding Cab/Chassis dimensions your Isuzu Dealer can access detailed Body Builders diagrams from the Isuzu Truck Technical Reference CD.

ISUZU NEW TRUCK WARRANTIES

STANDARD TRUCKPOWER WARRANTY*			TRUCKPOWER EXTENDED WARRANTY OPTIONS [#]		
NEW VEHICLE	3 years	200,000 km	4 years / 300,000 km	5 years / 350,000 km	6 years / 400,000 km
DRIVETRAIN	3 years	200,000 km			
CAB CORROSION	3 years	unlimited			

Why have Isuzu Trucks been Australia's No. 1 choice since 1989? *

- Widest range of models to suit most applications
- Premium componentry and Isuzu diesel engines
- Network of over 40 specialist Isuzu Dealerships and branches
- Sales, services and parts support
- Predictable operating costs through Dealer ISIS program
- Factory and range of extended warranties available
- High resale values
- Leading reputation for reliability

www.isuzu.com.au

* Source Truck Tracker 2002

* Subject to the conditions outlined in the I-GM New Vehicle Warranty, the Isuzu FVR & FVD HD models carry a standard factory warranty which covers the owner: (i) for the entire vehicle, for the first 36 months or 200,000 km (whichever comes first). (ii) for the drivetrain, which runs concurrently, for 36 months or 200,000 km (whichever comes first). (iii) against cab corrosion, for 36 months and unlimited kilometres.

A TruckPower Extended Warranty as illustrated is available by purchase to cover the owner against the failure of original components, but excludes some components and expendable items such as oil, filters, etc. Please consult with your Isuzu Dealer for full details obtained from a dedicated brochure available to customers.

ISUZU-GENERAL MOTORS AUSTRALIA LTD A.C.N. 006 962 572. PLEASE NOTE: as the policy of I-GM is one of continual product improvement, all specifications and equipment are subject to change without notice. No I-GM dealer or other person is authorised or permitted to give or make any statement, assertion or undertaking in relation to the quality, performance, characteristics, descriptions or fitness for any purpose of any I-GM product or in connection with the supply of any I-GM product which is at variance with any written statement, assertion or undertaking on any of these subjects given or made by I-GM in its published sales literature, and the company accepts no liability for any such unauthorised action. I-GM has franchised dealers in many parts of Australia, for the sale of service, parts and the provision of service to the owners of I-GM products. Every endeavour is made to ensure that such dealers carry adequate stocks of service parts and are equipped to provide satisfactory service, but makes no promise, other than that contained in the I-GM new vehicle warranty, that such parts or service facilities will be available or available at any specific location or at any particular time. A word about this specification sheet. We have tried to make it as comprehensive and factual as possible. However, since the time of printing some of the information you will find here may have been updated. Also, some of the equipment shown or described through this specification sheet may have been changed and/or is available at extra cost. And the right is reserved to make changes at any time without notice, in prices, colours, materials, equipment and models. Your I-GM dealer has details and before ordering, you should ask him/her to bring you up to date.

SEPTEMBER 2003. ARK/IGM 0093

ISUZU

RELIABILITY IS EVERYTHING