

ISUZU

SPECIFICATIONS

NPR 300 Tipper

NPR 300 Tipper Crew



NPR 300 Tipper Crew



NPR 300 Tipper

AUSTRALIA'S TOP SELLING TRUCK BRAND SINCE 1989.

AT A GLANCE

GVM	6,500 kg
GCM	10,000 kg
Power	114 kW @ 2,600 rpm
Torque	419 Nm @ 1,600 - 2,600 rpm

ADVANCED TECHNOLOGY

Emissions: Euro V / ADR 80/03	Anti-lock Braking System (ABS)
Meets EEV emissions standard	Anti Skid Regulator (ASR)
Driver and passenger airbag with seatbelt pretensioner	Hill Start Aid (HSA)
ECE-R29 compliant cab	Electric mirrors
	Front and rear stabiliser bars



ISUZU

RELIABILITY IS EVERYTHING

NPR 300 Tipper

NPR 300 Tipper Crew

DRIVELINE AND CHASSIS SPECIFICATIONS

ENGINE: SITEC SERIES III 155 (ISUZU 4HK1-TCN)

- Type:** 4 cylinder 16 valve SOHC
Displacement: 5,193 cc
Compression ratio: 17.5:1
Bore x Stroke: 115 mm x 125 mm
Max power (Din-net): 114 kW (153 HP) @ 2,600 RPM
(JIS Gross): 118 kW (158 HP) @ 2,600 RPM
Max torque (Din-net): 419 Nm (309 lb.ft) @ 1,600 - 2,600 RPM
(JIS Gross): 434 Nm (320 lb.ft) @ 1,600 - 2,600 RPM
Induction system: Electronically controlled variable nozzle turbocharger with air-to-air intercooler.
Fuel injection: Direct injection high pressure common rail system.
Emission control system: Cooled EGR with exhaust Diesel Particulate Diffuser (DPD). ADR 80/03 (Euro V) compliant. EEV compliant.

CLUTCH

- Auto adjusting hydraulic control with vacuum assistance. Single plate 325 mm diameter.
- Total lining area: 966 cm²

TRANSMISSION

Isuzu MYY-6S

- 6 speed manual. Synchromesh on gears 1-6.
 - Gear ratios (: 1)
- | 1st | 2nd | 3rd | 4th | 5th | 6th | Rev |
|-------|-------|-------|-------|-------|-------|-------|
| 5.979 | 3.434 | 1.862 | 1.297 | 1.000 | 0.750 | 5.701 |

AXLES

Front: Isuzu F031

- Reverse Elliot I-beam. 3,100 kg capacity.

Rear: Isuzu R066

- Full floating Banjo type. Four differential pinions. 6,600 kg capacity.
- Drive ratio: 4.300:1

SUSPENSION

Front:

- **Single cab:** Single stage alloy steel taper leaf springs.
- **Crew cab:** Single stage alloy steel multi leaf springs.
- Double acting hydraulic shock absorbers. Stabiliser bar.

Rear:

- Multi leaf main spring, multi leaf helper spring.
- Double acting hydraulic shock absorbers. Stabiliser bar

BRAKES

- Auto adjusting front disc and rear drum brakes with dual circuit hydraulic control, vacuum assistance and electronic brake force distribution (EBD).
- ABS and ASR traction control.
- Hill Start Aid (HSA).
- Front disc diameter: 293 mm
- Rear drum size: 320 x 100 mm
- 190 mm diameter drum park brake mounted on rear of transmission.
- Vacuum controlled exhaust brake.

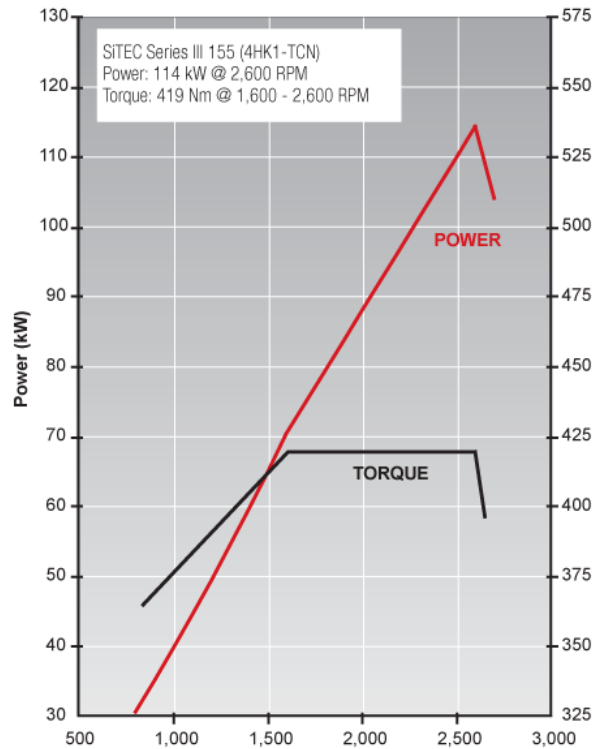

STEERING

- Power assisted recirculating ball steering.
- Gear ratio: 20.9:1
- Turns lock to lock: 5.4
- Maximum angle: 43° (inside wheel) / 33° (outside wheel)

WHEELS AND TYRES

- 17.5 x 6.00 six stud steel wheels.
- **Steer axle:** 215/75R 17.5 126/124M Michelin XZE2 Tubeless
- **Drive axle:** 215/75R 17.5 126/124M Michelin XDE2 Tubeless
- Maximum tyre rating:
 - Steer axle: 3,400 kg
 - Drive axle: 6,400 kg
- Spare wheel and tyre assembly supplied.

CHASSIS FRAME

- Cold rivetted ladder frame. SAPH440 weldable steel sidemembers. Parallel side rails and rivetless top flange.
- Frame dimensions:
 - Side rail (mm): 216 x 70 x 6.0
 - Rear frame width (mm): 850

TIPPER BODY

- All steel body with drop sides. Auto release two-way tailgate.
- Auto release body lockdown hook.
- Shovel rack. LHS and RHS rope rails. Non-slip side steps.
- 20 second raise / 20 second lower time.
- Cubic volume: 3.0 m³ (single cab), 2.8 m³ (crew cab)
- Deck plate thickness: 3.2 mm
- Side / front / tail plate thickness: 2.3 mm

FUEL TANK

- Frame mounted 140L steel fuel tank.
- Lockable fuel cap.

ELECTRICAL SYSTEM

- 24 volt electrical system.
- 80 amp alternator.
- 4.5 kW starter motor.
- 2 x 80D26L (630 CCA) batteries connected in series.

CABIN SPECIFICATIONS AND APPOINTMENTS

CAB EXTERIOR

- All steel construction. High tensile steel used for cab underframe.
Single cab: Manual cab tilt to 45° with torsion bar assistance.
- Complies with ECE-R29 cab strength standard.
- **Single cab:** Liquid filled front and rear cab mounts. **Crew cab:** Rubber cab mounts.
- Heavy duty non slip entry steps.
- 90° opening internally reinforced front doors.
- Water spray suppression guards and front mudflaps.
- Laminated windscreen with shade band.
- Two speed windscreen wipers with intermittent wipe mode.
- Halogen multi-reflector headlamps incorporating turn signals. Additional door mounted side indicator lamps.
- Combination brake, turn, reverse and marker lamps, registration plate illumination lamps. Reverse alarm.
- Roof mounted clearance lamps.
- Heated and powered exterior main mirrors with flat glass and additional independently adjustable convex "spot" mirrors.
- Body coloured grille.
- Body coloured impact resisting polycarbonate bumper with steel backing frame.

CAB INTERIOR

- Contoured adjustable driver's bucket seat.
- Front passenger bench seat with 2 seat capacity.
- **Crew cab:** Engine access provided under removable driver seat base and tiltable front passenger seat.
- **Crew cab:** Rear bench seat with 4 seat capacity.
- 3-point lap sash seatbelts in all outboard seating positions. Driver and outboard front passenger seatbelts fitted with pretensioner. Centre seat lap belts.
- Driver and outboard front passenger airbag.
- Door and roof pillar entry assist grips. **Crew cab:** Full width rear grab rail with ashtray.
- Full interior trim, padded roof lining and vinyl floor covering. Driver and passenger windscreen header storage shelf.
- Tilt/Telescopic adjustable steering column, soft feel urethane steering wheel.
- Electric windows.
- Central locking with remote keyless entry and immobiliser.
- Twin cup holders. 24V cigarette lighter. Dashboard hook.
- Front door mounted storage pockets and driver's side ashtray.
- Centre console box with storage tray. Fold down storage tray behind centre seat backrest.
- Fully integrated air conditioning and heater/demister with 4-speed fan and outlets for windscreen, side windows, face and floor.

- Interior lamp with On/Door/Off switch. **Single cab:** fluorescent type. **Crew cab:** standard type.
- 2 DIN, two speaker radio/CD multimedia unit with 4.8" LCD touch screen and Bluetooth. Provision for SD card, USB and 3.5 mm plug inputs.
- DIN sized compartment for storage or for CB radio installation.

DRIVER CONTROLS

- Key-operated engine start/stop and steering lock. Engine idle speed control.
- HSA slow/fast engagement control and on/off switch.
- ASR on/off.
- DPD regeneration.
- **Left side combination stalk:** Windscreen wipers, washers and exhaust brake.
- **Right side combination stalk:** Turn signals and headlamps.
- PTO engage switch.
- Tip body raise and lower lever with safety release mechanism.

INSTRUMENTATION

- Electronically driven speedometer and tachometer. Digital odometer with integrated dual tripmeter. Engine coolant temperature and fuel level gauges.
- **Warning lamps:** Check engine, oil pressure, ABS, SRS airbag, alternator charge, service brakes, park brake, seat belt unfastened, low fuel level.
- **Indicator lamps:** HSA, warm up system, high beam, ASR, DPD status, exhaust brake, turn signals, PTO engaged.

OPTIONS AND GENUINE ACCESSORIES

Include the following (extra cost, request a brochure and further details from your Isuzu dealer):

- Isuzu satellite navigation - integrates with multimedia unit.
- Airbag compatible bullbar.
- 3,500 kg rated towbar.
- Air deflector.

ISUZU CARE

Isuzu Care gives truck owners access to products and services including Roadside Assist, Service Agreements, Extended Care, Extended Isuzu Assist and the Isuzu Care Centre. Call 1800 035 640.



ISUZU
RELIABILITY IS EVERYTHING

WEIGHTS (kg)

Models	Ratings*		Loading Limit* (at ground)		Cab Chassis Mass #		
	GVM	GCM	Front	Rear	Front	Rear	Total
NPR 300 Tipper	6,500	10,000	3,100	6,000	1,960	1,650	3,610
NPR 300 Tipper Crew	6,500	10,000	3,100	6,000	2,105	1,765	3,870

Maximum Gross Trailer Mass: 750 kg (unbraked), 3,500 kg (braked). * Vehicle ratings and front/rear weight limits are subject to government regulatory requirements and weight distribution analysis. Consult your Isuzu dealer to select the correct vehicle for your specific application. # Cab chassis only as supplied and including 10 litres of fuel.

DIMENSIONS (mm)

Turn Circle (m)

Models	WB	OAL	OAW	OAH	FOH	ROH	RT	ORT	CW	KERB TO KERB
NPR 300 Tipper	3,365	5,870	2,360	2,260	1,100	1,285	1,650	2,115	1,995	12.4
NPR 300 Tipper Crew	4,175	6,680	2,360	2,280	1,100	1,285	1,650	2,115	1,995	15.3

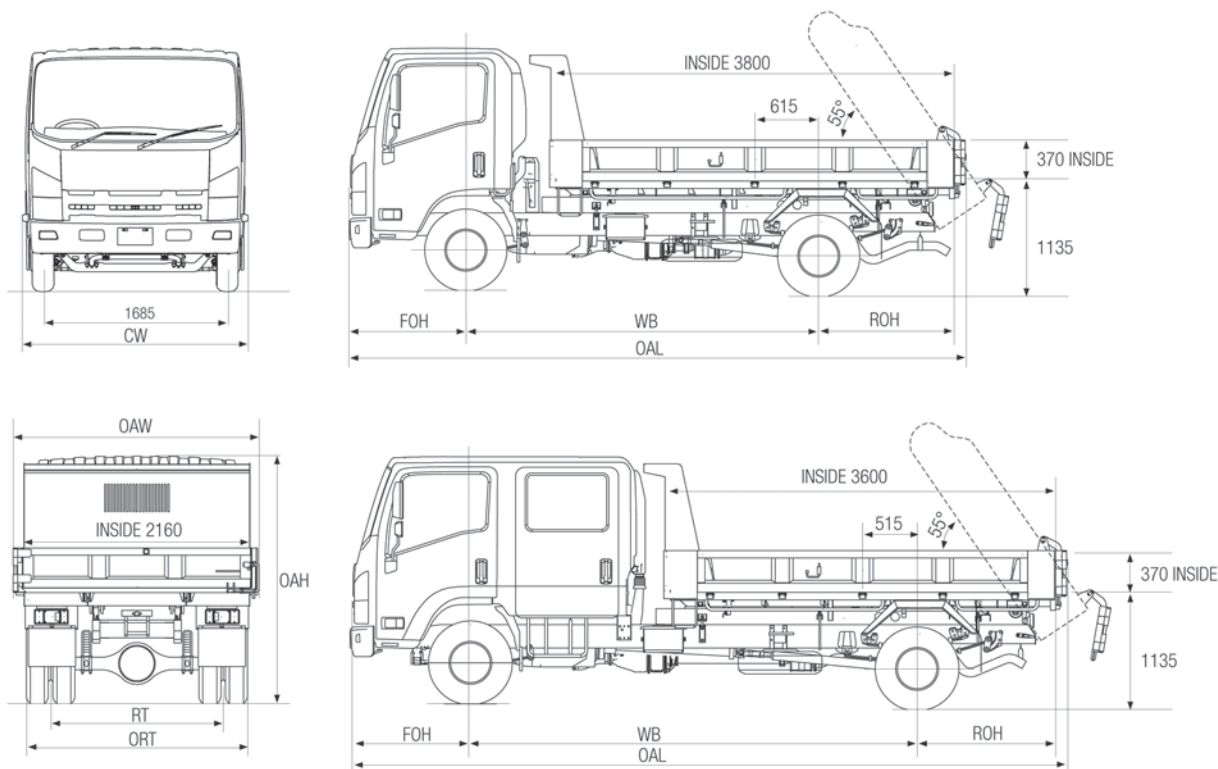

PERFORMANCE (calculated - typical paved road)

	Geared Speed* (top gear at peak power engine RPM)	Low Speed Gradeability (lowest forward gear assuming no wheel slip)	Engine Speed (top gear at 100km/h)
NPR 300 Tipper	At 6,500 kg GVM 114 km/h @ 2,600 RPM	40%	2,290 RPM
NPR 300 Tipper Crew	At 6,500 kg GVM 114 km/h @ 2,600 RPM	40%	2,290 RPM

*Maximum speed achievable depends on vehicle frontal area as well as other factors. Consult your Isuzu dealer for more detailed information.

ISUZU WARRANTIES

STANDARD¹

New Vehicle 3 years • 100,000km • 2,000 hours

Cab Perforation Corrosion 3 years • unlimited km's

Isuzu Assist: 24 hour roadside assistance (3 years, unlimited km's)*

EXTENDED CARE²

Extended Warranty: 5 years • 250,000km • 4,500 hours

Isuzu Assist: 24 hour roadside assistance (5 years, unlimited km's)

ORDER CODES

Model	Code
NPR 300 Tipper	NH-NPRZB-B11
NPR 300 Tipper Crew	NH-NPRNB-B11

¹ Subject to the conditions outlined in the IAL New Vehicle Warranty, the Isuzu NPR models carry a standard factory warranty which covers the owner: (i) for the entire vehicle, for the first 36 months or 100,000 km or 2,000 hrs (whichever comes first), (ii) against cab perforation corrosion, for 36 months and unlimited kilometres. ² Extended Warranty as illustrated may be purchased to cover the owner against the failure of original components, but may exclude some components and expendable items such as oil, filters, etc. *Valid for three years from the date of new vehicle purchases. All Isuzu warranties are subject to mandatory prescribed terms under Australian Consumer law including customer guarantees. For more details visit the Isuzu website which explains Isuzu warranties in more detail, or alternatively contact your local dealer. All warranties commence from date of delivery.

ISUZU AUSTRALIA LIMITED ABN 97 006 962 572 ("IAL"). The information in this spec sheet was correct at time of printing, but all measurements, specifications and equipment are subject to change without notice. Some equipment may have been changed and/or is available at extra cost. IAL may make changes at any time without notice, in prices, colours, materials, equipment and models. IAL makes all reasonable attempts to ensure the availability of all vehicles and equipment. The information in this spec sheet is general in nature. Your Isuzu dealer can confirm all measurements, specifications and vehicle / equipment availability upon request. To the extent permitted by the law, IAL is not liable to any person as result of reliance on the content of this spec sheet.

December 2012. ARK0643



ISUZU
RELIABILITY IS EVERYTHING