

450

FSR 450 SHORT

GVM 9,000 kg
GCM 15,000 kg
WHEELBASE 3,730 mm

ISUZU 6BD1 ENGINE PERFORMANCE

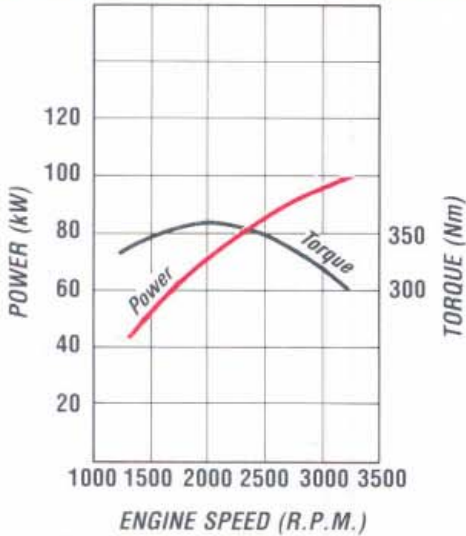

- Type: 6 Cylinder OHV Diesel, four stroke, direct injection
- Bore x Stroke (mm) 102 x 118
- Displacement 5785 (cc)
- Compression ratio (:1) 17.0
- Output-Power (kW) 100 @ 3200 rpm (DIN Nett)
- Torque (Nm) 353 @ 2000 rpm (DIN Nett)

DIMENSIONS

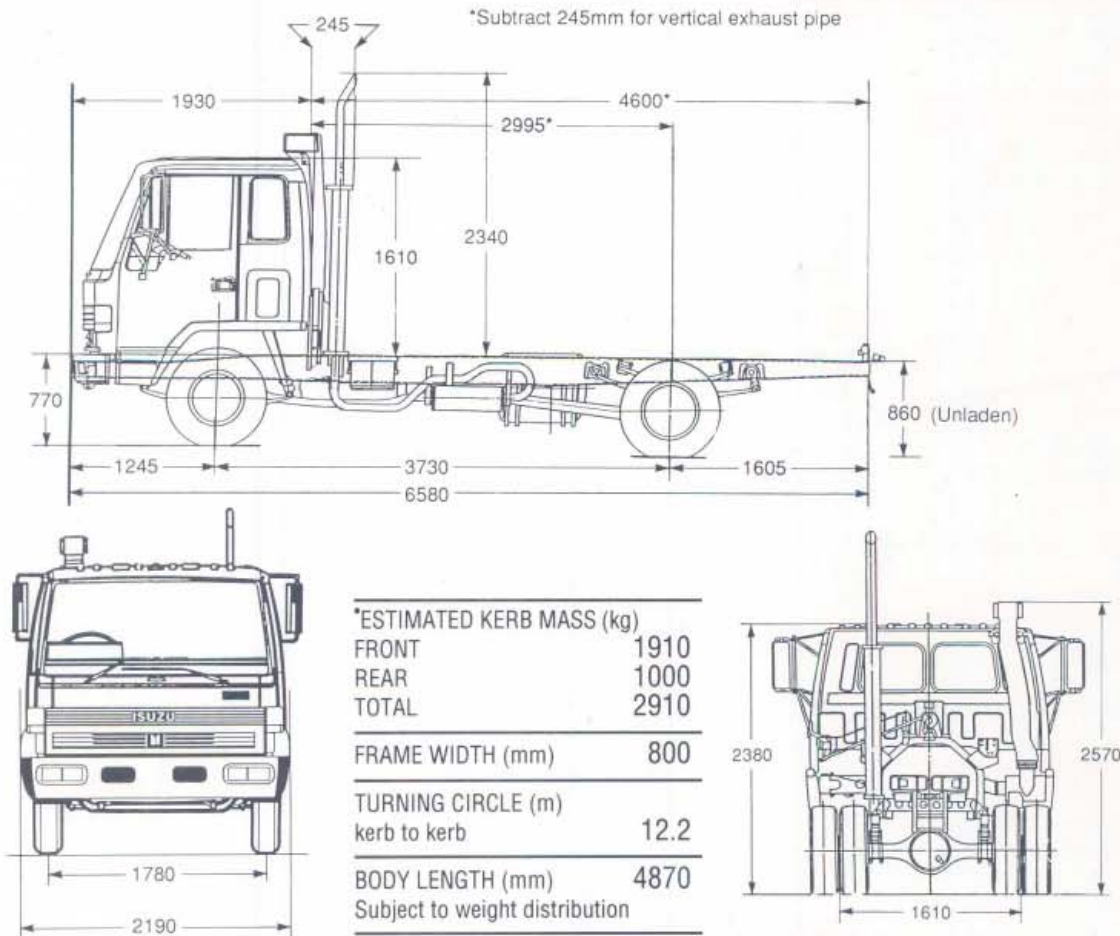

*Chassis and cab with oil, water and fuel tank containing 10 litres of fuel.

ISUZU-GENERAL MOTORS AUSTRALIA LTD A.C.N. 006 962 572

12/50 WARRANTY. Every Isuzu Truck is covered by the I-GM new vehicle warranty which covers your vehicle for the first 12 months or 50,000 kilometres.

PLEASE NOTE: as the policy of Isuzu-General Motors Australia Motors is one of continual product improvement, all specifications and equipment are subject to change without notice. Body illustrated are not standard. No I-GM dealer or other person is authorised or permitted to give or make any statement, assertion or undertaking in relation to the quality performance characteristics descriptions or fitness for any purpose of any I-GM product or in connection with the supply of any I-GM product which is at variance with any written statement assertion or undertaking on any of these subjects given or made by Isuzu-General Motors Australia Limited in its published sales literature, and the company excepts no liability for any such unauthorised action. Isuzu-General Motors Australia Limited has franchised dealers in many parts of Australia. For the sale of service parts and the provision of service to owners of I-GM products. Every endeavour is made to ensure that such dealers carry adequate stocks of service parts, and are equipped to provide satisfactory service, but makes no promise, other than that contained in the New Vehicle Warranty given by Isuzu-General Motors Australia Limited, that such parts or service facilities will be available, or available at any specific location or any particular time.

CT2911-10/91

ISUZU



ISUZU 450

FSR 450 SHORT

ORDERING CODE
8ED02-311

ENGINE-ISUZU 6BD1

Lubrication:

- Pressure feed lubrication with full flow, paper element filter, oil cooler. Oil capacity 12.5 litres including filter.

Cooling System:

- Six blade plastic cooling fan. Size 475mm Diameter.
- Tube and corrugated fin pressure type radiator size (mm) 662h x 559w x 53t frontal area 0.348m².

FUEL SYSTEM

- Two stage paper element air cleaner, Donaldson 11" with high vertical air intake stack and rain head.
- In line plunger, Bosch 'A' type fuel injection pump with mechanical all speed governor.
- In line paper filter, see through water separator with drain cock.
- Fuel tank capacity 160 litres.
- Horizontal exhaust muffler with vertical stack.

CLUTCH

- Hydraulic control, dry single plate with coil type cushioning springs. 325mm (13") Diameter, lining area 966cm² (Both sides).

TRANSMISSION - ISUZU MBG5C

- Five speed, direct drive, constant mesh, synchromesh on gears 2-5. Oil capacity 5 litres.
- **Gear Ratio:1**

1st	6.890
2nd	3.918
3rd	2.419
4th	1.569
5th	1.000
Reverse	6.304
- Maximum geared speed 103km/h
- Two piece propeller shaft 90mm diameter
- **Length:**

1st section	678mm
2nd section	1,129mm

REAR AXLE - CAPACITY 7.700kg

- Banjo type, fully floating, single reduction. Ratio 4.750:1
- Hypoid type ring gear, 343mm diameter. Oil capacity 5.5 litres.

REAR SUSPENSION - CAPACITY 11.020kg

- Semi elliptical, alloy steel, tapered, multi leaf springs. Fully wrapped eye with greasable shackles.
- Size: Length x width x thickness

Main:	1300 x 70 x 11mm - 8 leaves
Auxiliary:	850 x 70 x 10mm - 7 leaves

FRONT AXLE - CAPACITY 3.400kg

- Reverse Elliot, I-beam type, King pin diameter 35mm with cylindrical roller thrust bearing.

FRONT SUSPENSION - CAPACITY 5.100kg

- Semi elliptical, alloy steel, tapered multi leaf springs. Fully wrapped eye with greasable shackles.
- Size: Length x width x thickness
1200 x 70 x 10mm - 8 leaves
- Hydraulic, double acting, telescopic shock absorbers.

STEERING

- Fully integral, power assisted, recirculating ball type. Gear ratio 22.4:1, Turns lock to lock 4.3 Gear driven vane type oil pump, oil capacity 2.0 litres.

BRAKES

- Air over hydraulic, dual circuit, front two leading, rear dual two leading, drum diameter 320mm front and rear. Total lining area 3082cm².
- Mechanical type parking brake, internal expanding on rear of transmission.
- Butterfly, vacuum controlled exhaust brake system, activation switch on wiper/washer control stalk.

CHASSIS FRAME

- Parallel rail, ladder type, channel section, cold riveted.
- Side member dimensions
225 x 70 x 6mm
- Frame reinforcement 189 x 4.5mm at back of cab.
- High tensile steel, HT55 weldable frame material.

WHEELS AND TYRES

- 600 GS x 16 - 6 stud disc wheels front and rear.
- 20mm bolt size
- 825 - 16lt - 14ply Olympic Trojan 130 Tubed tyres front and rear.
- Options 8.25R - 16Lt - 14Ply Yokohama Y785 Tubed radial tyres front and rear.
- Number of tyres 7, including spare.
- Winch type spare wheel carrier.

ELECTRICAL SYSTEM

- Batteries 2 x 12 volt - 53 amp/hour, negative earth
- Alternator 24 volt - 40 amp
- Starter motor 24 volt - 4.5kw output
- Rear stop and tail lamps and licence plate lamp with long leads for variable body mounting, turn signal side indicator lamps for body mounting.

CAB EXTERIOR

- All steel cab, manual tilt to 45°. Cation electro deposition primer. Torsion bar counter balanced.
- Heavy duty bumper bar with four rectangular halogen headlamps inset.

- Access to engine fluid checks without tilting cab.
- Combination turn signal and park lamps.
- West Coast type rear view mirrors with clearance lamps.
- Laminated windshield, 2 speed wiper with intermittent mode and washers.
- Front and rear quarter vent windows.
- Corrosion resistant non slip cab entry steps.
- Tool kit with 7,000 kg capacity jack.

CAB INTERIOR

- Fully trimmed cab interior with cloth seat facings, formed roof lining and overhead parcel shelf with driver and passenger sunvisors.
- ISRI 5000 driver's seat with mechanical suspension, adjustment for seat back recline, seat slide and height control.
- Outboard passenger seat, folding centre seat back with lockable compartment and snack tray.
- Outboard lap/sash seat belts with emergency locking retractor, inboard lap seat belt.
- Soft feel urethane steering wheel
- Easy entry grab handles on a pillar
- Heater Demister with 4 speed fan, 4 outlet vents to screen, 5 fascia outlets, 5 foot outlets.
- AM/FM radio with digital clock, dash mounted.

INSTRUMENTATION

- Speedometer, odometer and tachometer.
- Gauges for coolant temperature, fuel level and brake air pressure.
- Dash illumination control.

INDICATOR LAMPS

- Turn signals, parking brake on, high beam on exhaust brake engaged, brake fluid level.

WARNING LAMPS

- With warning bulb checking switch
- Battery charge, oil filter clogged, oil pressure, low air pressure, brake system, air cleaner clogged, stop and tail lamp failure.

SWITCHES

- Left side combination switch for exhaust brake, wipers and washers.
- Hazard lamp switch.
- Right side combination switch for headlamps, turn signals and headlamp dip.
- Key operation for engine stop and start, external engine crank switch for service when cab is tilted.
- 24 Volt 2 pin accessory plug on centre fascia panel.
- Three way switch for interior lamp activated by driver and passenger doors.