

800

FTR 800 LONG

GVM 13,500 kg
GCM 20,400 kg
WHEELBASE 5000 mm

ISUZU 6BG1 ENGINE PERFORMANCE

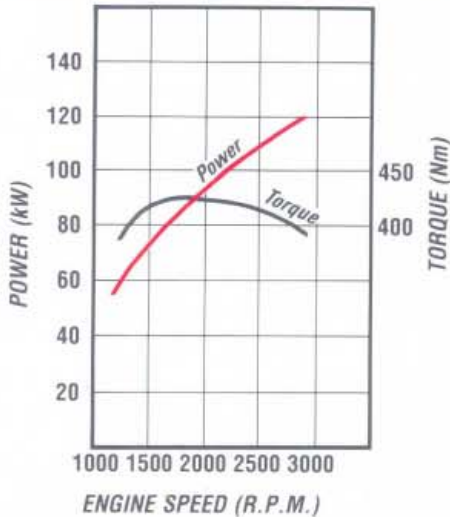

- Type: 6 Cylinder OHV diesel, four stroke, direct injection
- Bore x Stroke (mm) 105 x 125
- Displacement 6494 (cc)
- Compression ratio (:1) 17.0
- Output-Power (kW) 120 @ 2860 rpm (DIN Nett)
- Torque (Nm) 431 @ 1800 rpm (DIN Nett)

DIMENSIONS

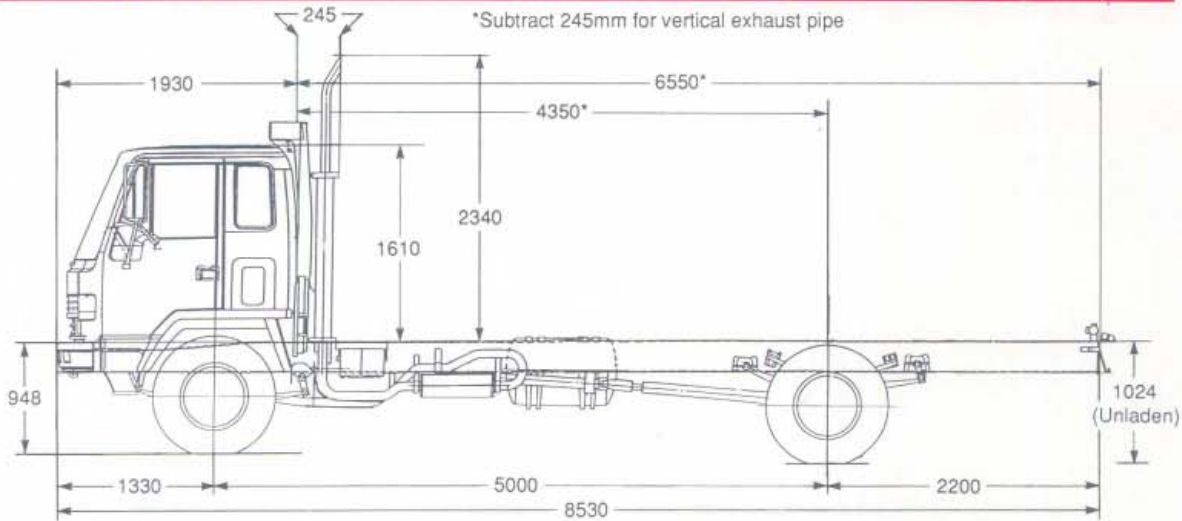

*ESTIMATED KERB MASS (kg)	
FRONT	2530
REAR	1790
TOTAL	4320
FRAME WIDTH (mm)	
	850
TURNING CIRCLE (m)	
kerb to kerb	17.1
BODY LENGTH (mm)	
	6700
Subject to weight distribution	

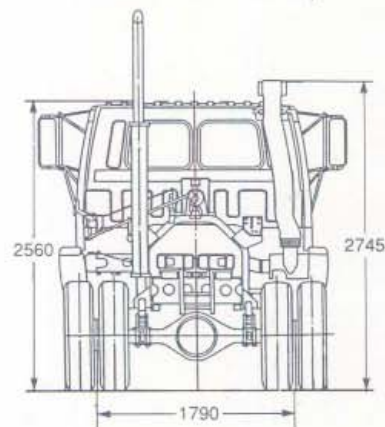

* Chassis and cab with oil, water and fuel tank containing 10 litres of fuel.

ISUZU-GENERAL MOTORS AUSTRALIA LTD. A.C.N. 006 962 572

12/50 WARRANTY. Every Isuzu truck is covered by the I-GM New Vehicle Warranty which covers your vehicle for the first 12 months or 50,000 kilometres.

PLEASE NOTE: As the policy of Isuzu-General Motors Australia Ltd. is one of continual product improvement, all specifications and equipment are subject to change without notice. Bodies illustrated are not standard. No I-GM Dealer or other person is authorised or permitted to give or make any statement, assertion or undertaking in relation to the quality performance characteristics descriptions or fitness for any purpose of any I-GM product or in connection with the supply of any I-GM product which is at variance with any written statement assertion or undertaking on any of these subjects given or made by Isuzu-General Motors Australia Ltd. in its published sales literature, and the company accepts no liability for any such unauthorised action. Isuzu-General Motors Australia Ltd. have franchised dealers in many parts of Australia for the sale of service parts and the provision of service to owners of I-GM products. Every endeavour is made to ensure that such dealers carry adequate stocks of service parts, and are equipped to provide satisfactory service, but makes no promise, other than that contained in the New Vehicle Warranty given by Isuzu-General Motors Australia Ltd. that such parts or service facilities will be available, or available at any specific location or any particular time.

CT2927-10/91

ISUZU





800

FTR 800 LONG

ORDERING CODE
8EP02-421

ENGINE - ISUZU 6BG1

Lubrication:

- Pressure feed lubrication with full flow paper element filter, oil cooler. Oil Capacity 12.5 litres including filter.

Cooling System:

- Six blade plastic cooling fan with thermatic clutch. Size 574 mm diameter.
- Tube and corrugated fin pressure type radiator. Size (mm) 622h x 559w x 53t. Frontal area 0.348 m² with bell mouth fan shroud.

FUEL SYSTEM

- Two stage paper element air cleaner. Donaldson 11" with high vertical air intake stack and rain head.
- In line plunger, Bosch 'A' type fuel injection pump with mechanical all speed governor.
- In line paper filter. See-through water separator with drain cock.
- Fuel tank capacity 200 litres.
- Horizontal exhaust muffler with vertical stack.

CLUTCH

- Hydraulic control, dry single plate with 6 coil type cushioning springs. 350 mm (14") diameter. Lining area 1164 cm² (both sides).

TRANSMISSION ISUZU MLD7R

- Seven speed overdrive, constant mesh with synchromesh on gears 2-7 and power assisted shift control. Oil capacity 8.3 litres.

Gear Ratios:1

1st	8.181
2nd	5.167
3rd	3.333
4th	2.105
5th	1.347
6th	1.000
7th	0.863
Reverse:	8.307

- Maximum geared speed 99.6 km/h
- Three piece propeller shaft, 90 mm diameter.

Length:

1st section:	686 mm
2nd section:	861 mm
3rd section:	1282 mm

REAR AXLE - CAPACITY 9,200 kg

- Banjo type, fully floating, single reduction.
- | | |
|------------------------|-------------|
| Ratio: | 6.143:1 |
| Hypoid type ring gear: | 398 mm diam |
| Oil Capacity: | 8 litres |

REAR SUSPENSION - CAPACITY 14,600 kg

- Semi elliptical, alloy steel, tapered multi leaf springs. Fully wrapped eye with greasable shackles.
- Size - length x width x thickness:
Main: 1420 x 80 x 12 mm - 1 leaf
1420 x 80 x 13 mm - 6 leaves

- Auxiliary: 1000 x 80 x 13 mm - 4 leaves
1000 x 80 x 12 mm - 2 leaves

- Stabiliser bar.

FRONT AXLE - CAPACITY 5,000 kg

- Reverse Elliot I-beam type. King pin diameter 45 mm with cylindrical roller thrust bearing.

FRONT SUSPENSION - CAPACITY 6,300 kg

- Semi elliptical, alloy steel, tapered multi-leaf springs. Fully wrapped eye with greasable shackles.
- Size - length x width x thickness:
1470 x 80 x 18.7 mm - 1 leaf
1470 x 80 x 20.8 mm - 2 leaves
- Stabiliser Bar
- Hydraulic, double acting, telescopic shock absorbers.

STEERING

- Fully integral, power assisted recirculating ball type. Gear ratio 22.4:1 turns lock to lock 5.4 .
- Gear driven vane type oil pump, oil capacity 3.5 litres.

BRAKES

- Air over hydraulic, dual circuit front and rear leading/trailing drum diameter. Front and rear 410 mm. Total lining area 4640 cm².
- Spring parking brake acting on rear wheels.
- Butterfly, air controlled, exhaust brake system. Activation switch on wiper/washer control stalk.

CHASSIS FRAME

- Parallel rail, ladder type, channel section, cold riveted.
- Side member dimensions
253 x 80 x 7.5 mm.
- Frame reinforcement angle section
240 x 72.5 x 4.5 mm at cab back.
- High tensile steel, HT55 weldable frame material.

WHEELS AND TYRES

- 7.00 T x 20-8 stud disc wheels front and rear, 20 mm bolt size.
- 9.00 R 20-14 ply Goodyear G291 tubed radial tyres front and rear. Number of tyres 7, including spare.
- Winch type spare wheel carrier.

ELECTRICAL SYSTEM

- Batteries 2 x 12 volt - 55 amp/hour , neg. earth.
- Alternator 24 volt - 40 amp .
- Starter motor 24 volt - 4.5 kW output .
- Rear stop and tail lamps and licence plate lamp with long leads for variable body mounting.
- Turn signal side indicator lamps for body mounting.

CAB EXTERIOR

- All steel cab, manual tilt to 45°. Cation electro deposition primer. Torsion bar counter balanced.

- Heavy duty bumper bar with four rectangular halogen headlamps inset.
- Access to engine fluid checks without tilting cab.
- Combination turn signal and park lamps.
- West Coast type rear view mirrors with clearance lamps.
- Laminated windshield, 2 speed wiper with intermittent mode and washers.
- Front and rear quarter vent windows.
- Corrosion resistant non-slip cab entry steps.
- Tool kit with 10,000 kg capacity jack.

CAB INTERIOR

- Fully trimmed cab interior with cloth seat facings, formed roof lining and overhead parcel shelf with driver and passenger sun visors.
- ISRI 5000 drivers seat with mechanical suspension adjustment for seat back recline, seat slide and height control.
- Folding centre seat back with lockable compartment and snack tray.
- Outboard lap/sash seat belts with emergency locking retractor, inboard lap seat belt.
- Tilt telescopic adjustable steering column with soft feel urethane steering wheel.
- Easy entry grab handles on 'A' and 'B' pillars.
- Heater, demister with 4 speed fan, 4 outlet vents, to screen, 5 fascia outlets, 5 foot outlets.
- AM/FM radio with digital clock, dash mounted.

INSTRUMENTATION

- Speedometer, odometer and tachometer.
- Gauges for coolant temperature, fuel level and brake air pressure.
- Dash illumination control.

INDICATOR LAMPS

- Turn signals, parking brake on, high beam on, exhaust brake engaged, brake fluid level.

WARNING LAMPS

- With warning bulb checking switch
- Battery charge, oil filter clogged, oil pressure, low air pressure, brake system, air cleaner clogged, stop and tail lamp failure.

SWITCHES

- Left side combination switch for exhaust brake, wipers and washer. Hazard lamp switch.
- Right side combination switch for headlamps, turn signals and headlamp dip.
- Key operation for engine start and stop, external engine crank switch for service when cab tilted.
- 24 Volt 2 pin accessory plug on centre fascia panel.
- Three way switch for interior lamp activated by driver and passenger doors.