

# ISUZU

## SPECIFICATIONS

# FYJ 2000 8X4 Agitator Cab Chassis



\* Please note: The FYJ 2000 Agitator Cab Chassis is available as a cab chassis only. Mixer barrel and accessories shown are for illustrative purposes and only available at extra cost.

**AUSTRALIA'S TOP SELLING TRUCK BRAND SINCE 1989.**

### AT A GLANCE

GVM	30,000 kg
GCM	42,500 kg
Power	257 kW @ 2,000 rpm
Torque	1,422 Nm @ 1,400 rpm

### ADVANCED TECHNOLOGY

Emissions: Euro V / ADR 80/03  
Driver airbag with seatbelt pretensioner  
ADR42 compliant sleeper with mattress  
ECE-R29 compliant cab  
ECE-R93 compliant Front Underun Protection Device (FUPD)  
Anti-lock Braking System (ABS)  
Cross locks

Electro-hydraulic cab tilt  
Coil spring cab suspension  
Front stabiliser bar  
Load sharing front suspension equaliser with shock absorber  
Cruise control  
ISRI 6860 seat with integrated seatbelt



We  
share  
the  
load.

**ISUZU**  
RELIABILITY IS EVERYTHING

# FYJ 2000 8X4 Agitator Cab Chassis

## DRIVELINE AND CHASSIS SPECIFICATIONS

### ENGINE: SITEC SERIES III 350 (ISUZU 6UZ1-TCN)

- Type:** 6 cylinder 24 valve SOHC
- Displacement:** 9,839 cc
- Compression Ratio:** 17.5:1
- Bore x Stroke:** 120 x 145 mm
- Max power (DIN-NET):** 257 kW (345 HP) @ 2,000 RPM  
**(JIS Gross):** 265 kW (355 HP) @ 2,000 RPM
- Max torque (DIN-NET):** 1,422 Nm (1,049 lb.ft) @ 1,400 RPM  
**(JIS Gross):** 1,472 Nm (1,086 lb.ft) @ 1,400 RPM
- Induction system:** Electronically controlled variable nozzle turbocharger with air-to-air intercooler.
- Fuel injection:** Direct injection high pressure common rail system.
- Emission control system:** Cooled EGR with exhaust Diesel Oxidation Catalyst (DOC). ADR 80/03 (Euro V) compliant.

### TRANSMISSION

#### ALLISON 4430 series

- 6 speed automatic. 5th generation electronic controls with adaptive shift.
- Allison long life TranSynd synthetic fluid.
- LHS and top PTO openings on transmission bellhousing. Engine driven PTO drive gear.
- Gear ratios (:1)
 

1st	2nd	3rd	4th	5th	6th	RV
4.70	2.21	1.53	1.00	0.76	0.67	5.55

### AXLES

#### Front: MERITOR

- 2x FG941 reverse Elliot I-beams. 6,600 kg capacity each.

#### Rear: MERITOR

- RT-40-145GP tandem axle set, 18,100kg capacity.
- Driver controlled inter-axle lock and cross locks on both axles.
- Drive ratio: 4.88:1

### SUSPENSION

#### Front:

- Single stage alloy steel taper-leaf springs.
- Double acting hydraulic shock absorbers fitted to both axles. Stabiliser bar fitted to 1st front axle.
- Load sharing front suspension equalisers with shock absorbers.

#### Rear:

- Hendrickson HAS461 airbag, 20,865 kg capacity at ground.
- Outboard mounted double acting shock absorbers.

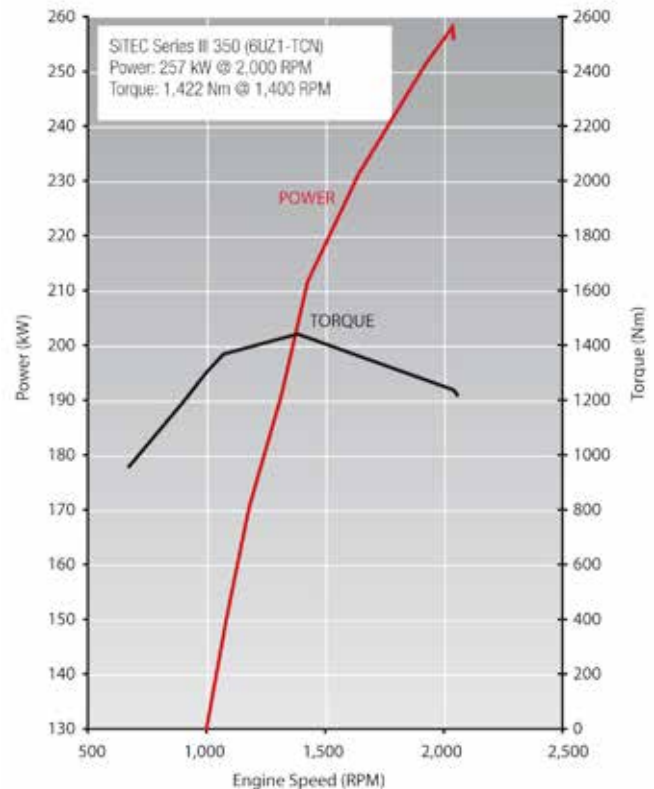

### BRAKES

- Meritor 'Q-Plus' dual circuit full air 'S-cam' front and rear drum brakes with auto slack adjusters.
- ABS.
- Front drum size: 419 x 152 mm
- Rear drum size: 419 x 178 mm
- Spring park brake acting on all rear wheels.
- Air controlled exhaust brake.
- Air dryer.

### STEERING

- Power assisted recirculating ball steering.
- Turns lock to lock: 3.8
- Overall gear ratio: 1st axle: 18.8:1, 2nd axle: 22.9:1
- Maximum angle:
  - 1st axle: 40.0° (inside wheel) / 32.2° (outside wheel)
  - 2nd axle: 34.0° (inside wheel) / 28.6° (outside wheel)

### WHEELS AND TYRES

- 22.5 x 8.25 ten stud ISO standard polished Alcoa aluminium wheels.
- 11R22.5 148/144M Yokohama Y785R Tubeless
- Maximum tyre rating:
  - Steer axle: 12,600 kg
  - Tandem drive axle set: 22,400 kg
- Spare wheel rim supplied.

## CHASSIS FRAME

- Cold rivetted ladder frame. HT540A high tensile weldable steel sidemembers.
- Frame dimensions:
  - Side rail (mm): 285 x 85 x 7.0
  - Rear frame width (mm): 850

## FUEL TANK

- Frame mounted 400L aluminium fuel tank.
- Lockable fuel cap.

## CABIN SPECIFICATIONS AND APPOINTMENTS

### CAB EXTERIOR

- All steel construction with electro-hydraulic cab tilt. High tensile steel used for cab underframe.
- Complies with ECE-R29 cab strength standard.
- Full floating cab with coil spring suspension and hydraulic shock absorbers.
- Heavy duty non slip entry steps.
- 90° opening internally reinforced front doors.
- Water spray suppression guards and front mudflaps.
- Laminated windscreen with shade band.
- Two speed windscreen wipers, with intermittent wipe mode.
- Halogen multi-reflector headlamps incorporating turn signals and front foglamps. Additional door mounted side indicator lamps.
- Combination brake, turn, reverse and marker lamps, registration plate illumination lamps. Extended wiring harness. Reverse alarm.
- Roof-mounted clearance lamps.
- Heated and powered exterior main mirrors with flat glass and additional powered convex "spot" mirrors.
- Chrome grille.
- Body coloured steel air dam bumper.
- FUPD underbar - complies with ECE-R93.

### CAB INTERIOR

- Isri 6860 air suspension driver's seat with pneumatic lumbar support, height, rake and automatic weight adjustment.
- Front passenger adjustable bucket seat and front centre seat with folding seat back.
- 3-point lap sash seatbelts in all outboard seating positions. Driver seatbelt with pretensioner integrated with driver seat. Centre seat lap belts.
- ADR 42 compliant sleeper with mattress.
- Driver airbag.
- Door and roof pillar entry assist grips.
- Full interior trim, padded roof lining and vinyl floor covering. Overhead front storage compartments.
- Tilt/Telescopic adjustable steering column, soft feel urethane steering wheel.
- Electric windows.
- Central locking with remote keyless entry.
- Twin cup holders. 24V cigarette lighter. Dashboard hook.
- Front door mounted storage pockets and driver's side ashtray.
- Centre console box with storage tray.
- Front passenger glovebox.
- Fully integrated auto control air conditioning and heater/demister with 4-speed fan and outlets for windscreen, side windows, face and floor.
- Fluorescent type interior lamp with On/Door/Off switch.

## ELECTRICAL SYSTEM

- 24 volt electrical system
- 90 amp alternator
- 24 volt, 5.0kW starter motor
- 2 x 80D26L (630 CCA) batteries connected in series

- 2 DIN, two speaker radio/CD/DVD Digital Audio Visual Entertainment (DAVE) unit with 6.2" LCD touch screen. DAB+ digital radio and fully integrated Bluetooth with voice recognition. 4GB internal storage for music files. USB/SD card and auxiliary input connection provisions.
- DIN sized compartment for storage or for CB radio installation.

### DRIVER CONTROLS

- Key-operated engine start/stop and steering lock. Engine idle speed control.
- Interaxle lock and cross lock engage switches.
- Pushbutton gear selection control.
- **Left side combination stalk:** Windscreen wipers, washers and exhaust brake.
- **Right side combination stalk:** Turn signals, headlamps and cruise control.

### INSTRUMENTATION

- Electronically driven speedometer and tachometer. Digital odometer with integrated dual tripmeter. Engine coolant temperature, fuel level and air pressure gauges.
- **Warning lamps:** Check engine, oil pressure, ABS, SRS airbag, alternator charge, service brakes, park brake, seatbelt unfastened, low air pressure, low fuel level, cab lock.
- **Indicator lamps:** Warm up system, high beam, exhaust brake, turn signals, inter-axle lock, cruise control.
- Transmission oil level, oil life, filter life, and condition monitor display.
- Multi-information display. Shows service interval, instantaneous and average fuel consumption, hourmeter, voltmeter, time/day/date and includes 40-120 km/h adjustable vehicle speed warning.

### OPTIONS AND GENUINE ACCESSORIES

Include the following (extra cost, request a brochure and further details from your Isuzu dealer):

#### Digital Audio Visual Entertainment unit:

- Isuzu satellite navigation including three years of free updates.
- Supports up to four camera inputs, one camera and rear microphone input active when reversing. Reversing sensors.
- Tyre pressure monitoring system.
- Cables for full iPod / iPhone / iPad compatibility and connection to other external audio visual devices.

#### Other:

- Airbag compatible bullbar.
- Air deflector.
- 270L aluminium fuel tank (replaces 400L fuel tank).

## ISUZU CARE

Isuzu Care gives truck owners access to products and services including Roadside Assist, Service Agreements, Extended Care, Extended Isuzu Assist and the Isuzu Care Centre. Call 1800 035 640.

### WEIGHTS (kg)

Models	Ratings*		Loading Limit* (at ground)		Cab Chassis Mass #		
	GVM	GCM	Front	Rear	Front	Rear	Total
FYJ 2000 Agitator Auto Cab Chassis	30,000	42,500	12,000	18,100	5630	2355	7985

\*Vehicle ratings and front/rear weight limits are subject to government regulatory requirements and weight distribution analysis. Consult your Isuzu dealer to select the correct vehicle for your specific application.  
# Cab chassis only as supplied and including 10 litres of fuel. Final weight dependent on individual vehicle application. Consult your Isuzu dealer for further information.

### DIMENSIONS (mm)

Models	WB	OAL	FOH	ROH	EA	CE	RT	ORT	CH	FFA (unladen)	RFA (unladen)	RFH (unladen)	Turn Circle (m)
													KERB TO KERB
FYJ 2000 Agitator Auto Cab Chassis	5,770	9,720	1,480	2,470	5,100	7,570	1,840	2,445	3,000	940	1,050	1,050	20.4

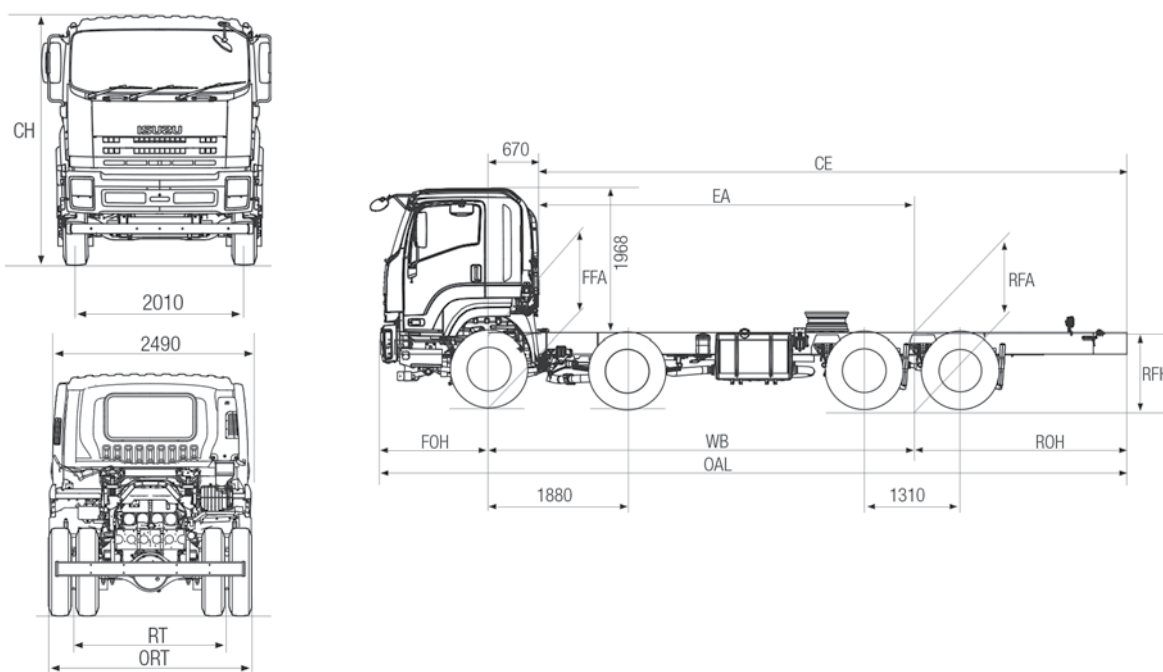

### PERFORMANCE (calculated - typical paved road)

Models	At 30,000 kg GVM	Geared Speed*	Low Speed Gradeability	Engine Speed
		(top gear at peak power engine RPM)	(lowest forward gear assuming no wheel slip)	(top gear at 100km/h)
FYJ 2000 Agitator Auto Cab Chassis	At 30,000 kg GVM	118 km/h @ 2,000 RPM	44%	1,690 RPM

\* Maximum speed achievable depends on vehicle frontal area as well as other factors. Consult your Isuzu dealer for more detailed information. Vehicle is speed limited to 100 km/h.

### ISUZU WARRANTIES

#### STANDARD<sup>1</sup>

New Vehicle 3 years • 250,000km • 4,000 hours

Isuzu Assist: 24 hour roadside assistance (3 years, unlimited kms)\*

#### EXTENDED CARE<sup>2</sup>

Extended Warranty: 5 years • 400,000km • 6,000 hours

Isuzu Assist: 24 hour roadside assistance (5 years, unlimited km's)

### ORDER CODES

Model	Code
FYJ 2000 Agitator Auto Cab Chassis	FH-FYJJJ-S15

<sup>1</sup> Subject to the conditions outlined in the IAL New Vehicle Warranty, the Isuzu FY models carry a standard factory warranty which covers the owner: (i) for the entire vehicle, for the first 36 months or 250,000 km or 4,000 hrs (whichever comes first), (ii) against cab perforation corrosion, for 36 months and unlimited kilometres. <sup>2</sup> Extended Warranty as illustrated may be purchased to cover the owner against the failure of original components, but may exclude some components and expendable items such as oil, filters, etc. \*Valid for three years from the date of new vehicle purchases. All Isuzu warranties are subject to mandatory prescribed terms under Australian Consumer law including customer guarantees. For more details visit the Isuzu website which explains Isuzu warranties in more detail, or alternatively contact your local dealer. All warranties commence from date of delivery.

ISUZU AUSTRALIA LIMITED ABN 97 006 962 572 ("IAL"). The information in this spec sheet was correct at time of printing, but all measurements, specifications and equipment are subject to change without notice. Some equipment may have been changed and/or is available at extra cost. IAL may make changes at any time without notice, in prices, colours, materials, equipment and models. IAL makes all reasonable attempts to ensure the availability of all vehicles and equipment. The information in this spec sheet is general in nature. Your Isuzu dealer can confirm all measurements, specifications and vehicle / equipment availability upon request. To the extent permitted by the law, IAL is not liable to any person as result of reliance on the content of this spec sheet. December 2015, ARK0868

We  
share  
the  
load.

**ISUZU**  
RELIABILITY IS EVERYTHING