

ISUZU

FVR950 MEDIUM/LONG

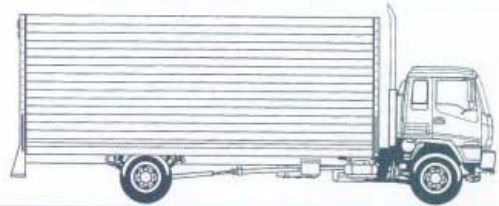

ENGINE ISUZU 6HH1-S

Type:	6 cylinder, overhead camshaft, 4 stroke, direct injection, diesel.
Bore x Stroke:	115 mm x 132 mm.
Displacement:	8226 cc.
Compression Ratio:	18.5 : 1.
Output - Power:	150 kW @ 2850 RPM. (ISO 1585)
Torque:	539 Nm @ 1700 RPM. (ISO 1585)

COOLING SYSTEM

- 6 blade plastic cooling fan 500 mm diameter with thermatic fan clutch.
- Corrugated fin radiator with fan shroud. Frontal area 3820 cm². Coolant capacity 23.3 litres.

CLUTCH

- Hydraulic control dry single plate. 355 mm (14") diameter.
- Asbestos free lining material. Total lining area (both sides) 1164 cm².

TRANSMISSION ISUZU MLD7R

- 7 speed overdrive, constant mesh with synchromesh on gears 2-7. Oil capacity 8.3 litres.
- Pneumatic gearshift assistance.
- Gear ratios (: 1)

1st	2nd	3rd	4th	5th	6th	7th	Rev
8.181	5.167	3.333	2.105	1.347	1.000	0.863	8.307
- Maximum geared speed 104 km/h. Electronically road speed limited to 100 km/h.
- 2 piece propeller shaft (950 Medium), 3 piece propeller shaft (950 Long), 90 mm diameter.

REAR AXLE: ROCKWELL RS-23-160 CAPACITY 10500 KG

- Banjo type, fully floating, single reduction. Ratio 6.14 : 1.
- Hypoid type ring gear. 457 mm diameter. Oil capacity 15.0 litres.

FRONT AXLE: ISUZU F063 CAPACITY 6300 KG

- Reverse Elliot I-beam type. King pin diameter 50 mm with cylindrical roller thrust bearing.

BRAKES

- Rockwell 'Q Plus' full air 'S' cam, dual circuit front and rear leading and trailing shoes. Drum diameter front and rear 419 mm. Total swept area 8688 cm².
- Asbestos free lining material.
- Air tank capacity 67.5 litres
- Spring park brake acting on rear wheels.

AIR INTAKE SYSTEM

Donaldson 11" two stage with vertical air intake stack and rain head.

ELECTRICAL SYSTEM

- Batteries - 2 x 12 volt / 65 amp/h, negative earth.
- Alternator - 24 volt / 40 amp.

- Starter motor - 24 volt / 4.5 kW.
- Rear stop and tail lamps and licence plate lamp with long leads for variable body mounting.

EXHAUST SYSTEM

- Horizontal exhaust muffler with vertical exhaust stack.
- Exhaust brake, air controlled.

FUEL SYSTEM

- In line plunger, Bosch 'ADS' type fuel injection pump with mechanical all speed governor. In line filter, see through water separator with drain cock. Single fuel tank, capacity 180 litres.

STEERING

- Fully integral, power assisted, recirculating ball type.
- Gear ratio 22.4 : 1. Turns lock to lock 4.5.
- Gear driven vane type oil pump. Oil capacity 2.5 litres.

SUSPENSION

FRONT

- Semi-elliptical, alloy steel tapered multi-leaf springs. Fully wrapped eye with greaseable shackles.
- | Length | x | Width | x | Thickness | x | No. leaves |
|---------|---|-------|---|-----------|---|------------|
| 1470 mm | x | 80 mm | x | 11 mm | x | 2 |
| | | 80 mm | x | 12 mm | x | 2 |
| | | 80 mm | x | 13 mm | x | 5 |
- Hydraulic, double acting, telescopic shock absorbers.
- Stabiliser bar.

REAR

- Semi-elliptical, alloy steel tapered multi-leaf springs. Fully wrapped eye with greaseable shackles.
- | Length | x | Width | x | Thickness | x | No. leaves |
|---------------|---|--------|---|-----------|---|------------|
| Main: 1420 mm | x | 100 mm | x | 12 mm | x | 8 |
| Aux: 980 mm | x | 100 mm | x | 10 mm | x | 2 |
| | | 100 mm | x | 11 mm | x | 4 |
- Stabiliser bar.

WHEELS AND TYRES

WHEELS

- 8.25 x 22.5, 10 stud disc wheels, 11R22.5 tubeless tyres front and rear.

REAR

- Number of wheels and tyres 7, including spare. Winch type spare wheel carrier.

CHASSIS FRAME

- Parallel rail, ladder type channel section, cold riveted.
- Straight frame for easy body mounting. Frame width 850 mm.
- Side member dimensions: FVR 950 Medium, 254 mm x 85 mm x 8 mm. Frame reinforcement angle section, 224 mm x 77 mm x 4.5 mm. FVR 950 Long, 258 mm x 85 mm x 10 mm. Frame reinforcement angle section, 224 mm x 75 mm x 4.5 mm.
- Material SAPH440 weldable mild steel.

LUBRICATION SYSTEM

- Pressure feed lubrication with combination full flow and partial flow by-pass filter. Plate type oil cooler in water jacket. Oil capacity 13.5 litres including filter.

CAB EXTERIOR

- All steel cab with welded strengthening ribs and side door impact beams. Torsion bar assisted manual tilt to 45°.
- 4 silicon filled rubber cab isolators.
- Cation electrodeposition primer.
- Bumper bar with step holes and footplate.
- Halogen headlamps, hinged for easy bulb replacement. Park lamps and cab clearance lamps.
- Turn signal lamps in front bumper and over wheel arches.
- 2 speed wiper/washer with variable intermittent mode. Triple washer jets mounted on wiper arms.
- Tinted, laminated windscreen; tinted, toughened side and rear glass.
- West Coast type rear view mirrors.
- Alloy non-slip cab entry steps.
- Lift up front access panel for clutch and windscreen washer fluids, cab air filter screen. Engine fluid check points at rear of cab.

CAB INTERIOR

- Fully trimmed cab interior with cloth seat facings, formed roof lining. Overhead storage lockers. Driver and passenger sun visors.
- Pull out drinks holder in centre fascia, cigarette lighter with ash trays in doors.
- Driver's seat with mechanical suspension and 3 way lumbar support. Adjustment for seat back recline, seat slide and weight control.
- Outboard reclining passenger seat with under-seat storage drawer. Folding centre seat back with lockable compartment and tray.
- Outboard lap/sash seat belts with emergency locking retractors, centre lap seat belt.
- Tilt/telescopic adjustable steering column, soft feel urethane steering wheel.
- Easy entry grab handles on 'A' and 'B' pillars.
- Heater demister with 4 speed fan, 4 outlet vents to screen, 5 fascia outlets, 5 foot outlets, demister ducts to door glass.
- AM/FM radio cassette with digital clock, dash mounted.
- DIN standard aperture in dash for CB radio.
- Park brake activation lever at left side of driver's seat.
- Rear vision mirror.
- Passenger side assist grip.
- Driver's left foot rest.
- Cab exhaust vents rear/upper cab.
- Business card clip. Coat hook at rear of cab.
- Elastic mesh pocket on driver's door.

CONTROLS

- Left side combination stalk switch for exhaust brake, windscreen wipers and washer, hazard lamps.
- Right side combination stalk switch for headlamps, high beam and turn signals.
- Engine idle speed adjust control.

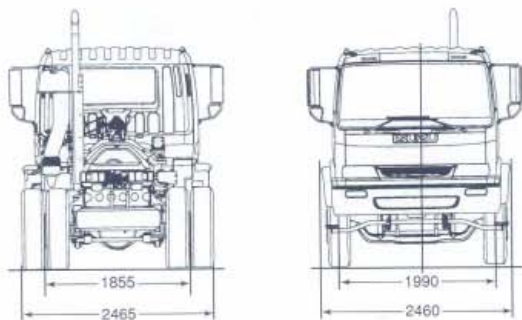

- Key operation for engine start and stop, external engine crank switch for service when cab is tilted.
- 3 way switch for interior lamp activated by driver and passenger doors.
- 24 volt-2 pin accessory plug in centre console.

INSTRUMENTATION

- Speedometer, odometer, trip meter and tachometer.
- Gauges for coolant temperature, fuel level and brake air pressure.
- WARNING LAMPS: With warning bulb check switch. Battery charge, oil pressure, low air pressure, brake system, stop and tail light failure.
- INDICATOR LAMPS: Turn signals, parking brake on, high beam on, exhaust brake engaged. Reversing lamp and beeper.

TOOLS

- Lockable tool box with 10000 kg capacity jack and wheel changing tools, tool kit.

MODELS, CODES & RATINGS

MODEL	WHEELBASE	GVM	GCM	ORDERING CODE
FVR 950 MEDIUM	4250mm	16000kg	24000kg	8FQ02-671
FVR 950 LONG	6050mm	16000kg	24000kg	8FR02-671

KERB MASS* (kg)

	Front	Rear	Total
FVR 950 MEDIUM	2,740	1,965	4,705
FVR 950 LONG	2,930	2,165	5,095

*Estimated mass of chassis cab with oil, water and fuel tank containing 10 litres of fuel. Excluding spare wheel and tools.

DIMENSIONS (mm)

	FVR 950 MEDIUM	FVR 950 LONG
WB Wheelbase	4,250	6,050
OAL Overall Length	7,420	10,020
ROH Rear Overhang	1,900	2,700
CA Cab To Axle	3,540	5,340
CE Cab To End Of Frame	5,440	8040
FFH Front Frame Height, Unladen	965	960
FFH Front Frame Height, Laden	941	941
RFH Rear Frame Height, Unladen	1,050	1,050
RFH Rear Frame Height, Laden	951	951
Turning Circle (Kerb To Kerb)	16.8m	22.5m
Nominal Max. Body Length*	5,645	8,395

*Except Turning Circle: metres. *Subject to weight distribution

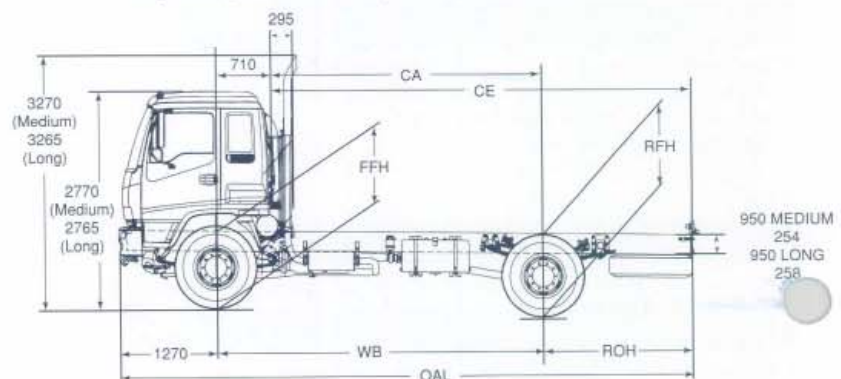

FVR950 MEDIUM/LONG

ISUZU

RELIABILITY IS EVERYTHING