

# ISUZU

## SPECIFICATIONS

# FRR 500

# Tipper



AUSTRALIA'S TOP SELLING TRUCK BRAND SINCE 1989.

### AT A GLANCE

|        |                    |
|--------|--------------------|
| GVM    | 10,400 kg          |
| GCM    | 16,000 kg          |
| Power  | 151 kW @ 2,600 rpm |
| Torque | 637 Nm @ 1,600 rpm |

### UPGRADE OPTIONS

**AMT Pack:** Automated Manual Transmission (AMT)

### ADVANCED TECHNOLOGY

|  |   |
|--|---|
| Emissions: Euro V / ADR 80/03            | Hill Start Aid (HSA)                    |
| Meets EEV emissions standard             | Electric mirrors                        |
| Driver airbag with seatbelt pretensioner | Front stabiliser bar                    |
| ECE-R29 compliant cab                    | Cruise control                          |
| Anti-lock Braking System (ABS)           | Isri 6860 seat with integrated seatbelt |
| Anti Skid Regulator (ASR)                |   |



THE  
**one**

**ISUZU**  
RELIABILITY IS EVERYTHING

# FRR Tipper

## DRIVELINE AND CHASSIS SPECIFICATIONS

### ENGINE: SITEC SERIES III 205 (ISUZU 4HK1-TCS)

- Type:** 4 cylinder 16 valve SOHC  
**Displacement:** 5,193 cc  
**Compression Ratio:** 17.5:1  
**Bore x Stroke:** 115 mm x 125 mm  
**Max power (DIN-NET):** 151 kW (202 HP) @ 2,600 RPM  
**(JIS Gross):** 157 kW (211 HP) @ 2,600 RPM  
**Max torque (DIN-NET):** 637 Nm (470 lb.ft) @ 1,600 RPM  
**(JIS Gross):** 659 Nm (486 lb.ft) @ 1,600 RPM  
**Induction system:** Electronically controlled variable nozzle turbocharger with air-to-air intercooler.  
**Fuel injection:** Direct injection high pressure common rail system.  
**Emission control system:** Cooled EGR with exhaust Diesel Particulate Diffuser (DPD). ADR 80/03 (Euro V) compliant. EEV compliant.

### CLUTCH

- Standard model:**
- Air assisted hydraulic control. Single plate 352 mm diameter.
  - Total lining area: 1,164 cm<sup>2</sup>
- AMT Pack:**
- Fully automated hydraulically controlled wet clutch and fluid coupling with lock up.

### TRANSMISSION

#### ISUZU MZW-6P

- Synchromesh on gears 2-6. Triple cone synchromesh on 2nd and 3rd gears. Integral oil pump provides full pressure lubrication.
  - Gear ratios (:1)
- | 1st   | 2nd   | 3rd   | 4th   | 5th   | 6th   | Rev   |
|-------|-------|-------|-------|-------|-------|-------|
| 6.615 | 4.095 | 2.358 | 1.531 | 1.000 | 0.722 | 6.615 |

#### Standard model:

- 6 speed manual with air assisted shift.

#### AMT Pack:

- 6 speed Automated Manual Transmission (AMT) with both fully automatic and clutchless manual operation modes.

### AXLES

#### Front: Isuzu F041

- Reverse Elliot I-beam. 4,100 kg capacity.

#### Rear: Isuzu R077

- Full floating Banjo type. 7,700 kg capacity.
- Drive ratio: 5.125:1

### SUSPENSION

#### Front:

- Single stage alloy steel multi leaf springs.
- Double acting hydraulic shock absorbers. Stabiliser bar.

#### Rear:

- Multi leaf main spring, multi leaf helper spring.

### BRAKES

- Dual circuit air over hydraulic front and rear drum brakes.
- ABS.
- ASR traction control.
- Hill Start Aid (HSA).
- Front drum size: 320 x 120 mm
- Rear drum size: 320 x 145 mm
- Spring park brake.
- Air controlled exhaust brake.
- Air dryer.

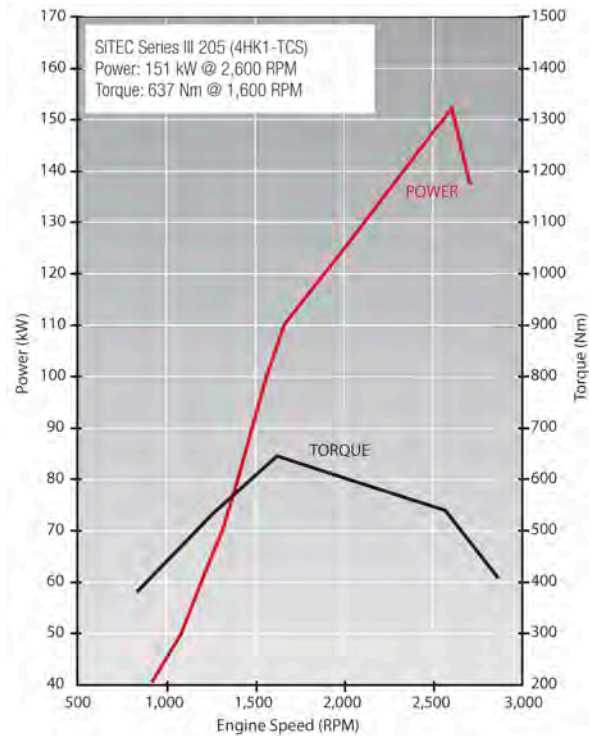

### STEERING

- Power assisted recirculating ball steering.
- Gear ratio: 16:1 - 18.8:1
- Turns lock to lock: 4.1
- Maximum angle: 52° (inside wheel) / 39° (outside wheel)

### WHEELS AND TYRES

- 17.5 x 6.00J six stud steel wheels.
- Steer axle: 9.5R17.5 129/127L Michelin XZA Tubeless
- Drive axle: 9.5R17.5 129/127L Michelin XZT Tubeless
- Maximum tyre rating:
  - Steer axle: 3,700 kg
  - Drive axle: 7,000 kg
- Spare wheel and tyre assembly supplied.

### CHASSIS FRAME

- Cold rivetted ladder frame with parallel side rails. HT540A high tensile weldable steel sidemembers.
- Frame dimensions:
  - Side rail (mm): 225 x 70 x 6.0
  - Rear frame width (mm): 840

### TIPPER BODY

- All steel body with drop sides. Auto release two-way tailgate.
- Auto release body lockdown hook.
- Shovel rack. LHS and RHS rope rails. Non-slip side steps.
- 20 second raise / 20 second lower time.
- Cubic volume: 3.8 m<sup>3</sup>
- Deck plate thickness: 6.0 mm
- Side / front / tail plate thickness: 3.2 mm

## FUEL TANK

- Frame mounted 200L steel fuel tank.
- Lockable fuel cap.

## ELECTRICAL SYSTEM

- 24 volt electrical system.
- 60 amp alternator.
- 24 Volt, 4.5 kW starter motor.
- 2 x 115E41L (651 CCA) batteries connected in series.

## CABIN SPECIFICATIONS AND APPOINTMENTS

### CAB EXTERIOR

- All steel construction. High tensile steel used for cab underframe. Manual cab tilt to 45° with torsion bar assistance.
- Complies with ECE-R29 cab strength standard.
- Liquid filled front and rear cab mounts.
- Heavy duty non slip entry steps.
- 90° opening internally reinforced front doors.
- Water spray suppression guards and front mudflaps.
- Laminated windscreen with shade band.
- Two speed windscreen wipers, with intermittent wipe mode.
- Halogen multi-reflector headlamps incorporating turn signals. Additional door mounted side indicator lamps.
- Combination brake, turn, reverse and marker lamps, registration plate illumination lamps. Reverse alarm.
- Roof mounted clearance lamps.
- Heated and powered exterior main mirrors with flat glass and additional powered convex "spot" mirrors.
- Body coloured grille.
- Body coloured steel bumper with front foglamps.

### CAB INTERIOR

- Isri 6860 air suspension driver's seat with pneumatic lumbar support, height, rake and automatic weight adjustment.
- Front passenger adjustable bucket seat and front centre seat with folding seat back.
- 3-point lap sash seatbelts in all outboard seating positions. Driver seatbelt with pretensioner integrated with driver seat. Centre seat lap belts.
- Driver airbag.
- **AMT Pack:** Driver's footrest.
- Door and roof pillar entry assist grips.
- Full interior trim, padded roof lining and vinyl floor covering. Driver and passenger windscreen header storage shelf.
- Tilt/Telescopic adjustable steering column, soft feel urethane steering wheel.
- Electric windows.
- Central locking with remote keyless entry and immobiliser.
- Twin cup holders. 24V cigarette lighter. Dashboard hook.
- Front door mounted storage pockets and driver's side ashtray.
- Centre console box with storage tray. Fold down storage tray behind centre seat backrest.
- Front passenger glovebox.
- Fully integrated air conditioning and heater/demister with 4-speed fan and outlets for windscreen, side windows, face and floor.
- Fluorescent type interior lamp with On/Door/Off switch.

- 2 DIN, two speaker radio/CD multimedia unit with 4.8" LCD touch screen and Bluetooth. Provision for SD card, USB and 3.5 mm plug inputs.
- DIN sized compartment for storage or for CB radio installation.

### DRIVER CONTROLS

- Key-operated engine start/stop and steering lock. Engine idle speed control.
- HSA slow/fast engagement control and on/off switch.
- ASR on/off.
- DPD regeneration.
- **Left side combination stalk:** Windscreen wipers, washers and exhaust brake.
- **Right side combination stalk:** Turn signals, headlamps and cruise control.
- **AMT Pack:** AMT slow/fast gear engagement control, 1st gear start and normal/economy gear selection modes.
- PTO engage switch.
- Tip body raise and lower lever with safety release mechanism.

### INSTRUMENTATION

- Electronically driven speedometer and tachometer. Digital odometer with integrated dual tripmeter. Engine coolant temperature, fuel level and air pressure gauges.
- **Warning lamps:** Check engine, oil pressure, ABS, SRS airbag, alternator charge, service brakes, park brake, seatbelt unfastened, low air pressure, low fuel level, cab lock. **AMT Pack:** Check AMT.
- **Indicator lamps:** HSA, warm up system, high beam, ASR, DPD status, exhaust brake, turn signals, cruise control, PTO engaged. **AMT Pack:** Econo-mode, 1st gear start.
- **AMT Pack:** Gear selection display.
- Multi-information display. Shows service interval, instantaneous and average fuel consumption, DPD bar chart, hourmeter, voltmeter, time/day/date and includes 40-120 km/h adjustable vehicle speed warning.

### OPTIONS AND GENUINE ACCESSORIES

Include the following (extra cost, request a brochure and further details from your Isuzu dealer):

- Satellite navigation - integrates with multimedia unit and includes NAVTEQ mapping.
- Airbag compatible bullbar.



**ISUZU**  
RELIABILITY IS EVERYTHING

### WEIGHTS (kg)

| Models             | Ratings* |        | Loading Limit* (at ground) |       | Cab Chassis Mass # |       |       |
|--------------------|----------|--------|----------------------------|-------|--------------------|-------|-------|
|                    | GVM      | GCM    | Front                      | Rear  | Front              | Rear  | Total |
| FRR 500 Tipper     | 10,400   | 16,000 | 3,700                      | 7,000 | 2,370              | 2,110 | 4,480 |
| FRR 500 Tipper AMT | 10,400   | 16,000 | 3,700                      | 7,000 | 2,385              | 2,115 | 4,500 |

\* Vehicle ratings and front/rear weight limits are subject to government regulatory requirements and weight distribution analysis. Consult your Isuzu dealer to select the correct vehicle for your specific application. # Cab chassis only as supplied and including 10 litres of fuel.

### DIMENSIONS (mm)

| Models         | WB    | OAL   | OAW   | OAH   | FOH   | ROH   | RT    | ORT   | CW    | Turn Circle (m) |
|----------------|-------|-------|-------|-------|-------|-------|-------|-------|-------|-----------------|
|                |       |       |       |       |       |       |       |       |       | KERB TO KERB    |
| FRR 500 Tipper | 3,784 | 6,255 | 2,360 | 2,520 | 1,157 | 1,205 | 1,660 | 2,152 | 2,200 | 12.0            |

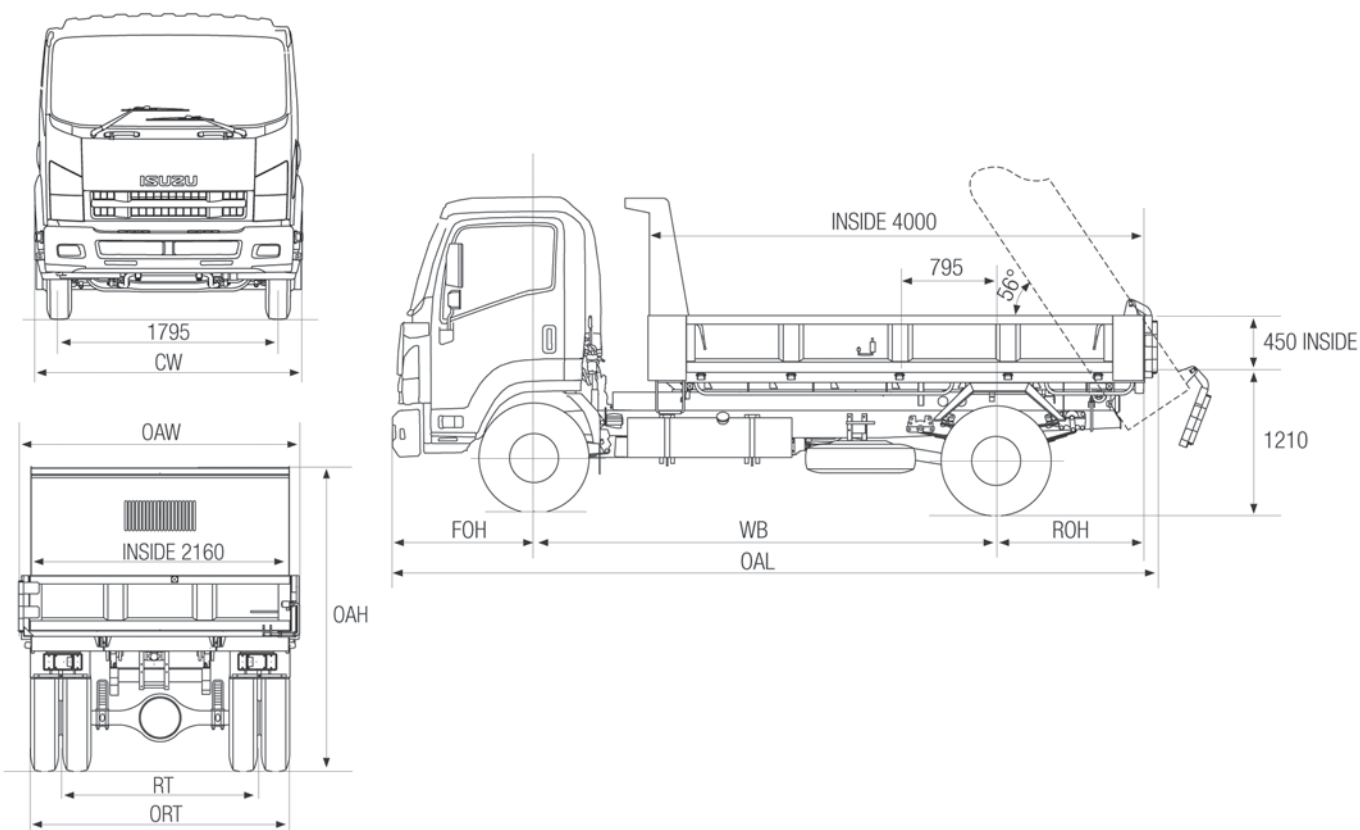

### PERFORMANCE (calculated - typical paved road)

|                |                 | Geared Speed*<br>(top gear at peak power engine RPM) | Low Speed Gradeability<br>(lowest forward gear assuming no wheel slip) | Engine Speed<br>(top gear at 100km/h) |
|----------------|-----------------|--|--|---------------------------------------|
| FRR 500 Tipper | At 10,400kg GVM | 109 km/h @ 2,600 RPM                                 | 46%  | 2,395 RPM                             |

\*Maximum speed achievable depends on vehicle frontal area as well as other factors. Consult your Isuzu dealer for more detailed information. Vehicle is speed limited to 100km/h.

### ISUZU WARRANTIES

| STANDARD <sup>1</sup>   |                                   |                     |
|---|-----------------------------------|---------------------|
| New Vehicle   | 3 years • 150,000km • 2,500 hours |                     |
| Cab Perforation Corrosion   | 3 years • unlimited km's          |                     |
| EXTENDED <sup>2</sup>   |                                   |                     |
| 4 years, 250,000km  | 5 years • 300,000km               | 6 years • 350,000km |
| Isuzu Assist - 24 hour roadside assistance (3 years, unlimited km's)* |                                   |                     |

### ORDER CODES

| Model              | Code         |
|--------------------|--------------|
| FRR 500 Tipper     | FH-FRRED-A11 |
| FRR 500 Tipper AMT | FH-FRRED-F11 |

<sup>1</sup> Subject to the conditions outlined in the IAL New Vehicle Warranty, the Isuzu FRR model carries a standard factory warranty which covers the owner: (i) for the entire vehicle, for the first 36 months or 150,000 km or 2,500 hrs (whichever comes first), (ii) against cab perforation corrosion, for 36 months and unlimited kilometres. <sup>2</sup> Extended Warranty as illustrated is available by purchase to cover the owner against the failure of original components, but may exclude some components and expendable items such as oil, filters, etc. Please consult with your Isuzu Dealer for full details obtained from a dedicated brochure available to customers. \*Valid for three years from the date of new vehicle purchases.

ISUZU AUSTRALIA LIMITED ABN 97 006 962 572 ("IAL"). The information in this brochure was correct at time of printing, but all measurements, specifications and equipment are subject to change without notice. Some equipment may have been changed and/or is available at extra cost. IAL may make changes at any time without notice, in prices, colours, materials, equipment and models. IAL makes all reasonable attempts to ensure the availability of all vehicles and equipment. The information in this brochure is general in nature. Your Isuzu dealer can confirm all measurements, specifications and vehicle / equipment availability upon request.

TIC: Isuzu is a member of the Truck Industry Council - Safer Greener Essential.

April 2011.ARK0551



**ISUZU**  
RELIABILITY IS EVERYTHING