

# FSR 550 LONG

GVM: 9500kg  
GCM: 15000kg  
WHEELBASE: 4800mm

# 550

## ISUZU 6HE1 ENGINE PERFORMANCE

- Type: 6 cylinder, overhead camshaft diesel, four stroke, direct injection
- Bore x stroke: 110 x 125 mm
- Displacement: 7127 cc
- Compression Ratio: 17.0:1
- Output -  
Power:  
129kW @ 3000 rpm (DIN Nett)  
Torque:  
471 Nm @ 1800 rpm (DIN Nett)

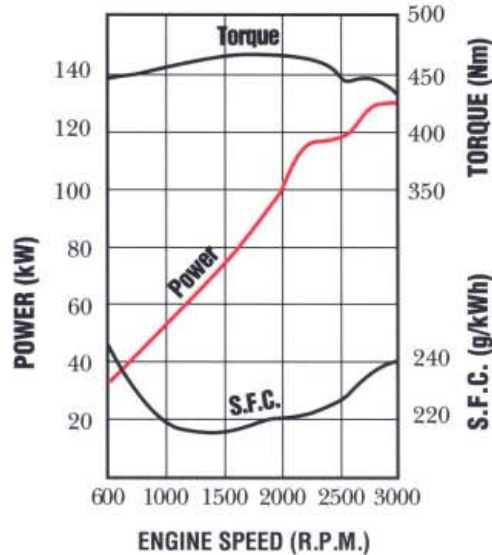

## DIMENSIONS AND WEIGHTS

*ESTIMATED KERB MASS (kg)	
FRONT	2085
REAR	1165
TOTAL	3250
FRAME WIDTH (mm)	800
TURNING CIRCLE (m)	
Kerb to Kerb	15.1
BODY LENGTH (mm)	6100
Subject to weight distribution	
CHASSIS HEIGHT (mm)	
At centre line of rear axle	
UNLADEN CHASSIS CAB	920
AT GVM	837

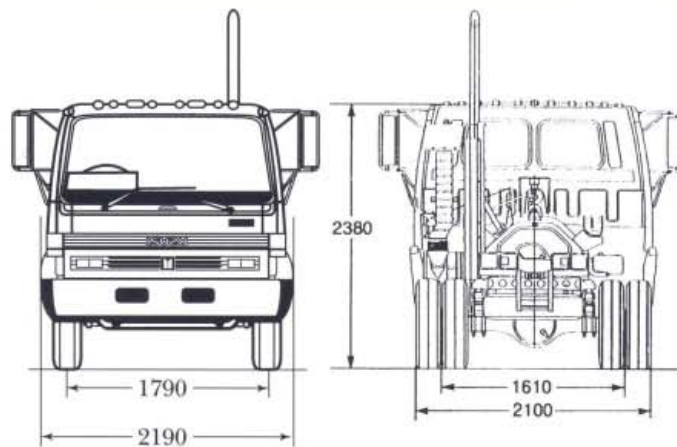

\*Chassis and cab with oil, water and fuel tank containing 10 litres of fuel.

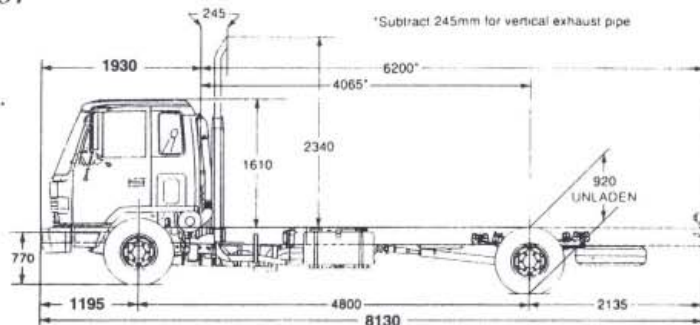

ISUZU-GENERAL MOTORS AUSTRALIA LTD A.C.N. 006 962 572.

12/50 WARRANTY. Every Isuzu Truck is covered by the I-GM new vehicle warranty which covers your vehicle for the first 12 months or 50,000 kilometres. PLEASE NOTE: as the policy of Isuzu-General Motors Australia Limited is one of continual product improvement, all specifications and equipment are subject to change without notice. Body illustrated is not standard. No I-GM dealer or other person is authorised or permitted to give or make any statement, assertion or undertaking in relation to the quality performance characteristics descriptions or fitness for any purpose of any I-GM product or in connection with the supply of any I-GM product which is at variance with any written statement, assertion or undertaking on any of these subjects given or made by Isuzu-General Motors Australia Limited in its published sales literature, and the company accepts no liability for any such unauthorised action. Isuzu-General Motors Australia Limited has franchised dealers in many parts of Australia, for the sale of service parts and the provision of service to owners of I-GM products. Every endeavour is made to ensure that such dealers carry adequate stocks of service parts, and are equipped to provide satisfactory service, but makes no promise, other than that contained in the New Vehicle Warranty given by Isuzu-General Motors Australia Limited, that such parts or service facilities will be available, or available at any specific location or any particular time.

## ENGINE - ISUZU 6HE1

### Lubrication

- Pressure feed lubrication with full flow paper element and partial flow sub filter. Plate type oil cooler in water jacket. Oil capacity 15 litres including filter.

### COOLING SYSTEM

- 6 blade plastic cooling fan size 470 mm diameter with thermatic fan clutch.
- Tube and corrugated fin pressure type radiator with bell mouth fan shroud. Size (mm) 622 h x 559 w x 52 t. Frontal area 0.348 m<sup>2</sup>.
- Coolant capacity 25 litres.

### FUEL SYSTEM

- Two stage paper element air cleaner, Donaldson 11" with vertical air intake stack and rain head.
- In line plunger, Bosch 'A' type fuel injection pump with mechanical all speed governor.
- In line paper filter, see through water separator with drain cock.
- Fuel tank capacity 180 litres.
- Horizontal exhaust muffler with vertical exhaust stack.

### CLUTCH

- Hydraulic control dry single plate with coil type cushioning springs. 350 mm (14") diameter.
- Asbestos free lining material. Total lining area (both sides) 1164 cm<sup>2</sup>.

### TRANSMISSION ISUZU MBG6P

- 6 speed overdrive, constant mesh, synchromesh on gears 2-6. Oil capacity 6.1 litres.
- Gear ratios: 1

1st	6.378
2nd	3.627
3rd	2.239
4th	1.452
5th	1.000
6th	0.787
Reverse	5.835

- Maximum geared speed 114 km/h.
- Two piece propeller shaft, 90 mm diameter.

Length: 1st section	1364 mm
2nd section	1302.5 mm

### REAR AXLE - R077 CAPACITY 7700 KG

- Banjo type, fully floating, single reduction. Ratio 5.125:1.
- Hypoid type ring gear, 343 mm diameter. Oil capacity 5.5 litres.

### REAR SUSPENSION

- Semi-elliptical, alloy steel tapered multi-leaf springs. Fully wrapped eye with greasable shackles.
- Length - Width x thickness No. leaves

Main:	1300 - 70 x 11 mm	8 leaves
Aux:	850 - 70 x 10 mm	7 leaves

### FRONT AXLE - F036 CAPACITY 3600 KG

- Reverse Elliot I-beam type. King pin diameter 35 mm with cylindrical roller thrust bearing.

### FRONT SUSPENSION

- Semi-elliptical, alloy steel tapered multi-leaf springs. Fully wrapped eye with greasable shackles.
- Length - Width x thickness No. leaves

1200 - 70 x 10 mm	8 leaves
-------------------	----------

- Hydraulic, double acting, telescopic shock absorbers.

### STEERING

- Fully integral power assisted recirculating ball type. Gear ratio 16.1-18.8:1. Turns lock to lock 4.6.
- Gear driven vane type oil pump, oil capacity 2.0 litres.

### BRAKES

- Air over hydraulic dual circuit, front two leading, rear dual two leading. Drum diameter front and rear 320 mm. Total swept area 5124.6 cm<sup>2</sup>.
- Air dryer.
- Asbestos free lining material.
- Spring park brake acting on rear wheels.
- Butterfly, air controlled exhaust brake. Activation switch on wiper/washer control stalk.

### CHASSIS FRAME

- Parallel rail, ladder type, channel section, cold rivetted.
- Side member dimensions 225 x 70 x 6 mm.
- Frame reinforcement 180 x 4.5 mm at back of cab.
- Material, SAPH45 mild steel.

### WHEELS AND TYRES

- 6.00 GS x 16 - 6 stud disc wheels, 20 mm bolt size. 135 mm offset.
- 8.25 R 16 LT - 14 ply Yokohama RY058 radial tyres front and rear.
- Number of tyres, 7 including spare.
- Winch type spare wheel carrier.

### ELECTRICAL SYSTEM

- Batteries - 2 x 12 volt - 53 amp/h, negative earth.
- Alternator - 24 volt - 40 amp.
- Starter motor - 24 volt - 4.5 kW output.
- Rear stop and tail lamps and licence plate lamp with long leads for variable body mounting. Turn signal side indicator lamps for body mounting.

### CAB EXTERIOR

- All steel cab, manual tilt to 45°. Torsion bar counter balanced.
- Cation, electro deposition primer.
- Heavy duty bumper bar.
- Four rectangular halogen headlamps.
- Combination turn signals and park lamps.
- Tinted laminated windshield, 2 speed wiper/washer with intermittent mode.
- Tinted quarter vent, side and rear glass.

- West Coast type rear view mirrors with clearance lamps.
- Corrosion resistant non slip cab entry steps.
- Access to engine fluid checks without tilting cab.
- Tool kit with 7000 kg capacity jack.

### CAB INTERIOR

- Fully trimmed cab interior with two tone cloth seat facings, formed roof lining and overhead parcel shelf with driver and passenger sunvisors.
- ISRI 6000 drivers seat with mechanical suspension and lumbar support, adjustment for seat back recline seat slide and height control.
- Outboard reclining passenger seat, folding centre seat back with lockable compartment and snack tray.
- Outboard lap/sash seat belts with emergency locking retractors, inboard lap seat belts.
- Tilt telescopic adjustable steering column, soft feel urethane steering wheel. Easy entry grab handles on 'A' and 'B' pillars.
- Heater demister with 4 speed fan, 4 outlet vents to screen, 5 fascia outlets, 5 foot outlets.
- AM/FM radio with digital clock, dash mounted.

### INSTRUMENTATION

- Speedometer, odometer and tachometer.
- Gauges for coolant temperature, fuel level and brake air pressure.
- Dash illumination control.

### INDICATOR LAMPS

- Turn signals, parking brake on, high beam on, exhaust brake engaged, brake fluid level.

### WARNING LAMPS

- With warning bulb check switch.
- Battery charge, oil filter clogged, oil pressure, low air pressure, brake system, air cleaner clogged, stop and tail lamp failure.
- Reversing lamp and beeper.

### SWITCHES

- Left side combination switch for exhaust brake, wipers and washer.
- Right side combination switch for headlamps, turn signals and headlamp dip.
- Hazard lamp switch.
- Key operation for engine stop and start, external engine crank switch for service when cab is tilted.
- Three way switch for interior lamp activated by driver and passenger doors.
- 24 volt 2 pin accessory plug on centre fascia panel.