

# ISUZU

## SPECIFICATIONS

### FSD 700-S | 850-S



FSD 850-S

AUSTRALIA'S TOP SELLING TRUCK BRAND SINCE 1989.

#### AT A GLANCE

GVM	12,000 / 14,000 kg*
GCM	18,000* / 20,000 kg*
Power	191 kW @ 2,400 rpm
Torque	761 Nm @ 1,450 - 2,400 rpm

\* Refer to back page weights table for details

#### UPGRADE OPTIONS

**Premium Pack:** Automated Manual Transmission (AMT) or conventional automatic transmission, Auto control for air conditioning, Chrome grille

#### ADVANCED TECHNOLOGY

Emissions: Euro V / ADR 80/03	Anti Skid Regulator (ASR) - except auto model
Meets EEV emissions standard	Hill Start Aid (HSA) - except auto model
Driver and passenger airbag with seatbelt pretensioner	Electric mirrors
ADR42 compliant sleeper	Front stabiliser bar
ECE-R29 compliant cab	Cruise control
ECE-R93 compliant front underun protection device (FUPD)	ISRI 6860 seat with integrated seatbelt
Anti-lock Braking System (ABS)	Cornering lamps

We  
share  
the  
load.

**ISUZU**  
RELIABILITY IS EVERYTHING



# FSD Long | Long Premium AMT | Long Premium

## DRIVELINE AND CHASSIS SPECIFICATIONS

### ENGINE: SITEC SERIES III 255 (ISUZU 6HK1-TCC)

- Type:** 6 cylinder 24 valve SOHC  
**Displacement:** 7,790 cc  
**Compression Ratio:** 17.5:1  
**Bore x Stroke:** 115 mm x 125 mm  
**Max power (DIN-NET):** 191 kW (256 HP) @ 2,400 RPM  
**(JIS Gross):** 198 kW (265 HP) @ 2,400 RPM  
**Max torque (DIN-NET):** 761 Nm (561 lb.ft) @ 1,450 - 2,400 RPM  
**(JIS Gross):** 788 Nm (581 lb.ft) @ 1,450 - 2,400 RPM  
**Induction system:** Electronically controlled variable nozzle turbocharger with air-to-air intercooler.  
**Fuel injection:** Direct injection high pressure common rail system.  
**Emission control system:** Cooled EGR with exhaust Diesel Particulate Diffuser (DPD). ADR 80/03 (Euro V) compliant. EEV compliant.

### CLUTCH (MANUAL/AMT TRANSMISSION MODEL)

- Standard model:**
- Air assisted hydraulic control. Single plate 381 mm diameter.
  - Total lining area: 1,363 cm<sup>2</sup>
- Premium Pack AMT:**
- Fully automated hydraulically controlled wet clutch and fluid coupling with lock up.

### TRANSMISSION

#### ISUZU MZW-6P (except auto model)

- Synchromesh on gears 2-6. Triple cone synchromesh on 2nd and 3rd gears. Integral oil pump provides full pressure lubrication.
  - PTO provision on LHS of transmission case. PTO drive from mainshaft gear.
  - Gear ratios (:1)
- | 1st   | 2nd   | 3rd   | 4th   | 5th   | 6th   | Rev   |
|-------|-------|-------|-------|-------|-------|-------|
| 6.615 | 4.095 | 2.358 | 1.531 | 1.000 | 0.722 | 6.615 |

#### Standard model:

- 6 speed manual with air assisted shift.

#### Premium Pack AMT:

- 6 speed Automated Manual Transmission (AMT) with both fully automatic and clutchless manual operation modes.

#### ALLISON LCT2500 (auto model)

- 6 speed automatic. 5th generation electronic controls with adaptive shift.
  - LHS and RHS PTO openings on transmission case. Torque convertor turbine driven PTO drive gear.
  - Gear ratios (:1)
- | 1st  | 2nd  | 3rd  | 4th  | 5th  | 6th  | Rev  |
|------|------|------|------|------|------|------|
| 3.51 | 1.90 | 1.44 | 1.00 | 0.74 | 0.64 | 5.09 |

### AXLES

#### Front: Isuzu F050

- Reverse Elliot I-beam. 5,000 kg capacity.

#### Rear: Isuzu R090

- Full floating Banjo type. 9,000 kg capacity.
- Drive ratio: 4.555:1 (manual/AMT model), 5.125:1 (auto model).

### SUSPENSION

#### Front:

- Single stage alloy steel taper leaf springs.
- Double acting hydraulic shock absorbers. Stabiliser bar.

#### Rear:

- Hendrickson HAS200 airbag. 9,000 kg capacity at ground.
- Outboard mounted double acting shock absorbers.

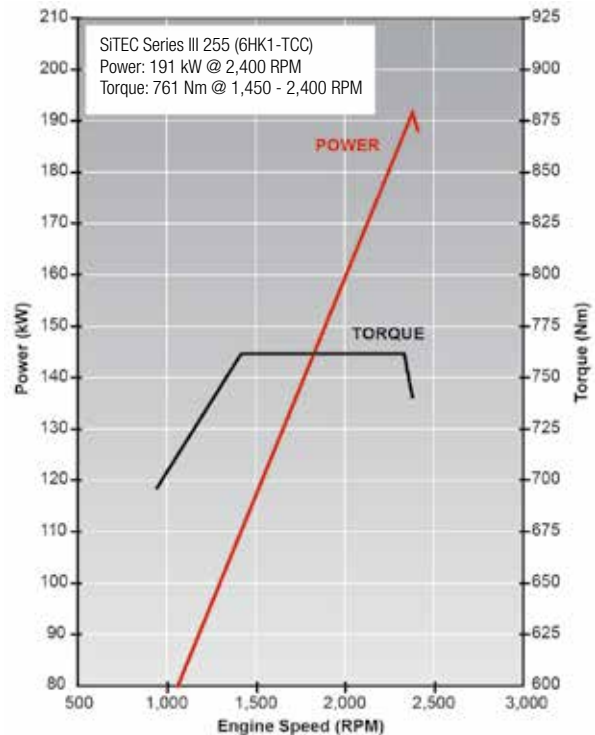

### BRAKES

- Dual circuit air over hydraulic front and rear drum brakes.
- ABS.
- ASR traction control - except auto model.
- Hill Start Aid (HSA) - except auto model.
- Front drum size: 370 x 150 mm
- Rear drum size: 370 x 150 mm
- Spring park brake.
- Air controlled exhaust brake.
- Air dryer.

### STEERING

- Power assisted recirculating ball steering.
- Gear ratio: 16:1 - 18.8:1
- Turns lock to lock: 4.1
- Maximum angle: 44° (inside wheel) / 34° (outside wheel)

### WHEELS AND TYRES

- 19.5 x 6.75 eight stud ISO standard steel wheels.
- 265/70R19.5 140/138M Michelin XZE2 Tubeless.
- Maximum tyre rating:
  - Steer axle: 5,000 kg
  - Drive axle: 9,440 kg
- Spare wheel and tyre assembly with winch type carrier.

### CHASSIS FRAME

- Cold rivetted ladder frame with parallel side rails. HT540A high tensile weldable steel sidemembers.
- Frame dimensions:
  - Side rail (mm): 225 x 70 x 6.0
  - Rear frame width (mm): 840

## FUEL TANK

- Frame mounted 200L steel fuel tank.
- Lockable fuel cap.

## ELECTRICAL SYSTEM

- 24 volt electrical system.
- 60 amp alternator.
- 24 Volt, 4.5 kW starter motor.
- 2 x 115E41L (651 CCA) batteries connected in series.
- Underdash CAN interface unit and connector. SAE J1939 protocol. Facilitates connection to a Fleet Management System (FMS) (not supplied).

## CABIN SPECIFICATIONS AND APPOINTMENTS

### CAB EXTERIOR

- All steel construction. High tensile steel used for cab underframe. Manual cab tilt to 45° with torsion bar assistance.
- Complies with ECE-R29 cab strength standard.
- Liquid filled front and rear cab mounts.
- Heavy duty non slip entry steps.
- 90° opening internally reinforced front doors.
- Water spray suppression guards and front mudflaps.
- Laminated windscreen with shade band.
- Two speed windscreen wipers with intermittent wipe mode.
- Halogen multi-reflector headlamps incorporating turn signals. Additional door mounted integrated side indicator/cornering lamps.
- Combination brake, turn, reverse and marker lamps, registration plate illumination lamps. Extended wiring harness. Reverse alarm.
- Roof-mounted clearance lamps.
- Heated and powered exterior main mirrors with flat glass and additional powered convex "spot" mirrors.
- **Except Premium Pack:** Body coloured grille. **Premium Pack:** Chrome grille.
- FUPD underbar - complies with ECE R93.
- Body coloured steel air dam bumper with front foglamps.

### CAB INTERIOR

- Isri 6860 air suspension driver's seat with pneumatic lumbar support, height, rake and automatic weight adjustment.
- Front passenger adjustable bucket seat and front centre seat with folding seat back.
- 3-point lap sash seatbelts in all outboard seating positions. Driver seatbelt with pretensioner integrated with driver seat. Outboard front passenger seatbelt fitted with pretensioner. Centre seat lap belts.
- ADR42 compliant sleeper.
- Driver and outboard front passenger airbag.
- **Premium Pack:** Driver's footrest.
- Door and roof pillar entry assist grips.
- Full interior trim, padded roof lining and vinyl floor covering. Driver and passenger windscreen header storage shelf.
- Tilt/Telescopic adjustable steering column, soft feel urethane steering wheel.
- Electric windows.
- Central locking with remote keyless entry and immobiliser.
- Twin cup holders. 24V cigarette lighter. Dashboard hook.
- Front door mounted storage pockets and driver's side ashtray.
- Centre console box with storage tray. Fold down storage tray behind centre seat backrest.
- Fully integrated air conditioning and heater/demister with 4-speed fan and outlets for windscreen, side windows, face and floor. **Except Premium Pack:** Manual control. **Premium Pack:** Auto control.
- Fluorescent type interior lamp with On/Door/Off switch.
- 2 DIN, two speaker radio/CD/DVD Digital Audio Visual Entertainment (DAVE) unit with 6.2" LCD touch screen DAB+ digital radio and fully integrated Bluetooth with

- voice recognition. 4GB internal storage for music files. USB/SD card and auxiliary input connection provisions.
- DIN sized compartment for storage or for CB radio installation.

### DRIVER CONTROLS

- Key-operated engine start/stop and steering lock. Engine idle speed control.
- HSA slow/fast engagement control and on/off switch - except auto model.
- ASR on/off - except auto model.
- DPD regeneration.
- **Premium Pack AMT:** AMT slow/fast gear engagement control, 1st gear start and normal/economy gear selection modes.
- T-bar gear selection control (Premium Pack auto model).
- **Left side combination stalk:** Windscreen wipers, washers and exhaust brake.
- **Right side combination stalk:** Turn signals, headlamps and cruise control.

### INSTRUMENTATION

- Electronically driven speedometer and tachometer. Digital odometer with integrated dual tripmeter. Engine coolant temperature, fuel level and air pressure gauges.
- **Warning lamps:** Check engine, oil pressure, ABS, SRS airbag, alternator charge, service brakes, park brake, seatbelt unfastened, low air pressure, low fuel level, cab lock. **Premium Pack AMT:** Check AMT.
- **Indicator lamps:** HSA (except auto model), warm up system, high beam, ASR (except auto model), DPD status, exhaust brake, turn signals, cruise control. **Premium Pack AMT:** Econo-mode, 1st gear start.
- **Premium Pack AMT:** Gear selection display.
- Multi-information display: Shows service interval, instantaneous and average fuel consumption, DPD bar chart, hourmeter, voltmeter, time/day/date and includes 40-120 km/h adjustable vehicle speed warning.

### OPTIONS AND GENUINE ACCESSORIES

Include the following (extra cost, request a brochure and further details from your Isuzu dealer):

#### Digital Audio Visual Entertainment unit:

- Isuzu satellite navigation including three years of free upgrades.
- Up to four reversing cameras - one with audio for reversing. Reversing sensors.
- Tyre pressure monitoring system.
- Cables for full iPod / iPhone / iPad compatibility and connection to other external audio visual devices.

#### Other:

- Airbag compatible bullbar.
- Air deflector.

## ISUZU CARE

Isuzu Care gives truck owners access to products and services including Roadside Assist, Service Agreements, Extended Care, Extended Isuzu Assist and the Isuzu Care Centre. Call 1800 035 640.

### WEIGHTS (kg)

Models	Ratings*		Loading Limit* (at ground)		Cab Chassis Mass #		
	GVM	GCM	Front	Rear	Front	Rear	Total
FSD 700-S / 850-S Long	12,000 / 14,000	18,000 / 20,000	5,000	9,000	2,545	1,505	4,050
FSD 700-S / 850-S Long Premium AMT	12,000 / 14,000	18,000 / 20,000	5,000	9,000	2,560	1,510	4,070
FSD 700-S / 850-S Long Premium Auto	12,000 / 14,000**	18,000** / 20,000**	5,000	9,000	2,550	1,505	4,055

\* Vehicle ratings and front/rear weight limits are subject to government regulatory requirements and weight distribution analysis. Consult your Isuzu dealer to select the correct vehicle for your specific application.

\*\* Pre-approved ratings as stated apply for general transport and distribution applications. For other applications approval from Allison is required. For example, GVM and GCM limits of 12,000kg apply for refuse application.

# Cab chassis only as supplied and including 10 litres of fuel.

### DIMENSIONS (mm)

Turn Circle (m)

Models	WB	OAL	FOH	ROH	EA	CE	RT	ORT	CH	FFA (unladen)	RFA (unladen)	RFH (unladen)	KERB TO KERB
FSD 700-S / 850-S	5,560	9,155	1,170	2,425	4,575	7,090	1,705	2,215	2,665	750	850	895	19.9

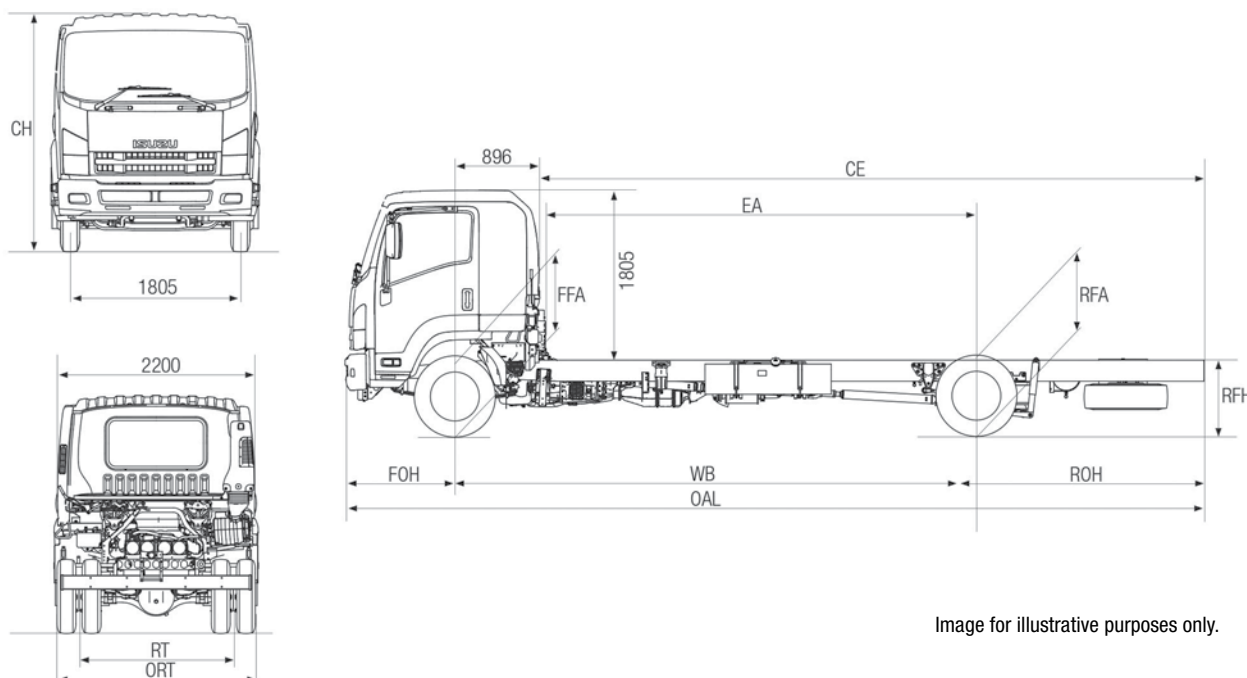

Image for illustrative purposes only.

### PERFORMANCE (calculated - typical paved road)

		Geared Speed* (top gear at peak power engine RPM)	Low Speed Gradeability (lowest forward gear assuming no wheel slip)	Engine Speed (top gear at 100km/h)
FSD 700-S	At 12,000 kg GVM	116 km/h @ 2,400 RPM	41%	2,070 RPM
FSD 700-S Auto	At 12,000 kg GVM	116 km/h @ 2,400 RPM	39%	2,065 RPM
FSD 850-S	At 14,000 kg GVM	116 km/h @ 2,400 RPM	35%	2,070 RPM
FSD 850-S Auto	At 14,000 kg GVM	116 km/h @ 2,400 RPM	33%	2,065 RPM

\* Maximum speed achievable depends on vehicle frontal area as well as other factors. Consult your Isuzu dealer for more detailed information. FSD 850-S models speed limited to 100km/h.

### ISUZU WARRANTIES

#### STANDARD<sup>1</sup>

New Vehicle 3 years • 150,000km • 2,500 hours

Cab Perforation Corrosion 3 years • unlimited km's

Isuzu Assist: 24 hour roadside assistance (3 years, unlimited km's)\*

#### EXTENDED CARE<sup>2</sup>

Extended Warranty: 5 years • 300,000km • 5,000 hours

Isuzu Assist: 24 hour roadside assistance (5 years, unlimited km's)

### ORDER CODES

Model	Code
FSD 700-S / 850-S Long	FH-FSDCH-D14
FSD 700-S / 850-S Long Premium AMT	FH-FSDDH-Z14
FSD 700-S / 850-S Long Premium Auto	FH-FSDDH-N14

<sup>1</sup> Subject to the conditions outlined in the IAL New Vehicle Warranty, the Isuzu FSD models carry a standard factory warranty which covers the owner: (i) for the entire vehicle, for the first 36 months or 150,000 km or 2,500 hrs (whichever comes first). (ii) against cab perforation corrosion, for 36 months and unlimited kilometres. <sup>2</sup> Extended Warranty as illustrated may be purchased to cover the owner against the failure of original components, but may exclude some components and expendable items such as oil, filters, etc. \*Valid for three years from the date of new vehicle purchases. All Isuzu warranties are subject to mandatory prescribed terms under Australian Consumer law including customer guarantees. For more details visit the Isuzu website which explains Isuzu warranties in more detail, or alternatively contact your local dealer. All warranties commence from date of delivery.

ISUZU AUSTRALIA LIMITED ABN 97 006 962 572 ("IAL"). The information in this spec sheet was correct at time of printing, but all measurements, specifications and equipment are subject to change without notice. Some equipment may have been changed and/or is available at extra cost. IAL may make changes at any time without notice, in prices, colours, materials, equipment and models. IAL makes all reasonable attempts to ensure the availability of all vehicles and equipment. The information in this spec sheet is general in nature. Your Isuzu dealer can confirm all measurements, specifications and vehicle / equipment availability upon request. To the extent permitted by the law, IAL is not liable to any person as result of reliance on the content of this spec sheet.

July 2014. ARK0762

We share the load.

**ISUZU**  
RELIABILITY IS EVERYTHING