

# ISUZU

## SPECIFICATIONS

# NQR 450

# Tipper AMT



AUSTRALIA'S TOP SELLING TRUCK BRAND SINCE 1989.

### AT A GLANCE

GVM	8,700 kg
GCM	12,200 kg
Power	139 kW @ 2,600 rpm
Torque	510 Nm @ 1,600 - 2,600 rpm

### ADVANCED TECHNOLOGY

Emissions: Euro V / ADR 80/03	Anti-lock Braking System (ABS)
Meets EEV emissions standard	Anti Skid Regulator (ASR)
Driver and passenger airbag with seatbelt pretensioner	Electric mirrors
ECE-R29 compliant cab	Front and rear stabiliser bars
	Cornering lamps



THE  
**one**

**ISUZU**  
RELIABILITY IS EVERYTHING

# NQR Tipper AMT

## DRIVELINE AND CHASSIS SPECIFICATIONS

### ENGINE: SITEC SERIES III 185 (ISUZU 4HK1-TCC)

- Type:** 4 cylinder 16 valve SOHC  
**Displacement:** 5,193 cc  
**Compression ratio:** 17.5:1  
**Bore x Stroke:** 115 mm x 125 mm  
**Max power (DIN - NET):** 139 kW (186 HP) @ 2,600 RPM  
**(JIS Gross):** 144 kW (193 HP) @ 2,600 RPM  
**Max torque (DIN - NET):** 510 Nm (376 lb.ft) @ 1,600 - 2,600 RPM  
**(JIS Gross):** 528 Nm (389 lb.ft) @ 1,600 - 2,600 RPM  
**Induction system:** Electronically controlled variable nozzle turbocharger with air-to-air intercooler.  
**Fuel injection:** Direct injection high pressure common rail system.  
**Emission control system:** Cooled EGR with exhaust Diesel Particulate Diffuser (DPD). ADR 80/03 (Euro V) compliant. EEV compliant.

### CLUTCH

- Fully automated hydraulically controlled wet clutch and fluid coupling with lock up.

### TRANSMISSION

#### Isuzu MZZ-6F

- 6 speed Automated Manual Transmission (AMT) with both fully automatic and clutchless manual operation modes.
- Gear ratios (:1)

1st	2nd	3rd	4th	5th	6th	Rev
6.369	3.767	1.966	1.355	1.000	0.782	6.369

### AXLES

#### Front: Isuzu F031

- Reverse Elliot I-beam. 3,100 kg capacity.

#### Rear: Isuzu R066

- Full floating Banjo type. Four differential pinions. 6,600 kg capacity.
- Drive ratio: 4.300:1

### SUSPENSION

#### Front:

- Single stage alloy steel taper leaf springs.
- Double acting hydraulic shock absorbers. Stabiliser bar.

#### Rear:

- Multi leaf main spring, multi leaf helper spring.
- Double acting hydraulic shock absorbers. Stabiliser bar.

### BRAKES

- Auto adjusting front disc and rear drum brakes with dual circuit hydraulic control, hydraulic pressure assistance and electronic brake force distribution (EBD).
- ABS and ASR traction control.
- Front disc diameter: 363 mm
- Rear drum size: 370 x 150 mm
- 203 mm diameter drum park brake mounted on rear of transmission.
- Vacuum controlled exhaust brake.

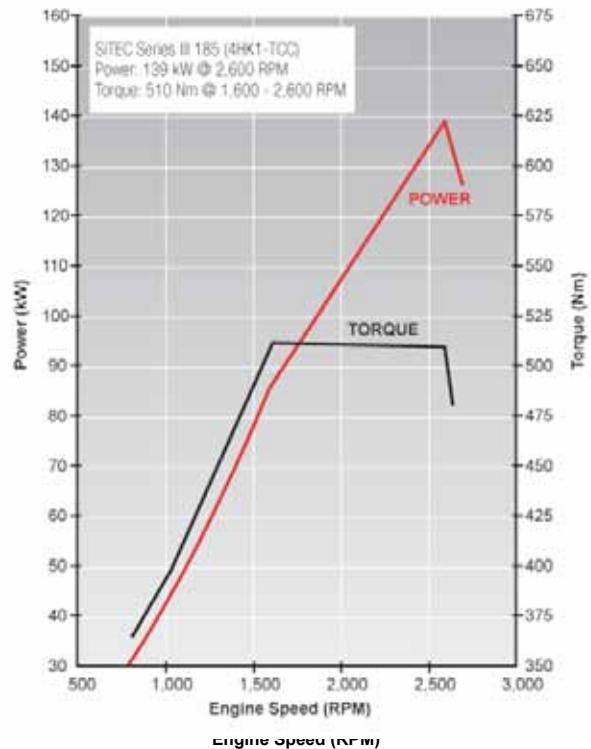

### STEERING

- Power assisted recirculating ball steering.
- Gear ratio: 20.9:1
- Turns lock to lock: 5.4
- Maximum angle: 43° (inside wheel) / 33° (outside wheel)

### WHEELS AND TYRES

- 19.5 x 6.00 six stud steel wheels.
- 225/70R 19.5 125/123L Michelin XZE Tubeless.
- Maximum tyre rating:
  - Steer axle: 3,300 kg
  - Drive axle: 6,200 kg
- 1 frame mounted spare wheel and tyre assembly.

### CHASSIS FRAME

- Cold rivetted ladder frame. SAPH440 weldable steel sidemembers. Parallel side rails and rivetless top flange.
- Frame dimensions:
  - Side rail (mm): 216 x 70 x 6.0
  - Rear frame width (mm): 850

### TIPPER BODY

- All steel body with drop sides. Auto release two-way tailgate.
- Auto release body lockdown hook.
- Shovel rack. LHS and RHS rope rails. Non-slip side steps.
- 20 second raise / 20 second lower time.
- Cubic volume: 3.6 m<sup>3</sup>
- Deck plate thickness: 4.5 mm
- Side / front / tail plate thickness: 3.2 mm

## FUEL TANK

- Frame mounted 140L steel fuel tank.
- Lockable fuel cap.

## ELECTRICAL SYSTEM

- 24 volt electrical system.
- 80 amp alternator.
- 4.5 kW starter motor.
- 2 x 80D26L (630 CCA) batteries connected in series.

## CABIN SPECIFICATIONS AND APPOINTMENTS

### CAB EXTERIOR

- All steel construction. High tensile steel used for cab underframe. Manual cab tilt to 45° with torsion bar assistance.
- Complies with ECE-R29 cab strength standard.
- Liquid filled front and rear cab mounts.
- Heavy duty non slip entry steps.
- 90° opening internally reinforced front doors.
- Water spray suppression guards and front mudflaps.
- Laminated windscreen with shade band.
- Two speed windscreen wipers with intermittent wipe mode.
- Halogen multi-reflector headlamps incorporating turn signals. Additional door mounted integrated side indicator/cornering lamps.
- Combination brake, turn, reverse and marker lamps, registration plate illumination lamps. Reverse alarm.
- Roof mounted clearance lamps.
- Heated and powered exterior main mirrors with flat glass and additional independantly adjustable convex "spot" mirrors.
- Body coloured grille.
- Body coloured impact resisting polycarbonate bumper with steel backing frame.

### CAB INTERIOR

- Contoured adjustable driver's bucket seat.
- Front passenger bench seat with 2 seat capacity.
- 3-point lap sash seatbelts in all outboard seating positions. Driver and outboard front passenger seatbelts fitted with pretensioner. Centre seat lap belts.
- Driver and outboard front passenger airbag.
- Driver's footrest.
- Door and roof pillar entry assist grips.
- Full interior trim, padded roof lining and vinyl floor covering. Driver and passenger windscreen header storage shelf.
- Tilt/Telescopic adjustable steering column, soft feel urethane steering wheel.
- Electric windows.
- Central locking with remote keyless entry and immobiliser.
- Twin cup holders. 24V cigarette lighter. Dashboard hook.
- Front door mounted storage pockets and driver's side ashtray.
- Centre console box with storage tray. Fold down storage tray behind centre seat backrest.
- Fully integrated air conditioning and heater/demister with 4-speed fan and outlets for windscreen, side windows, face and floor.
- Fluorescent type interior lamp with On/Door/Off switch.
- 2 DIN, two speaker radio/CD/DVD Digital Audio Visual Entertainment (DAVE) unit with 6.2" LCD touch screen. DAB+ digital radio and fully integrated Bluetooth with voice recognition. 4GB internal storage for music files. USB/SD card and auxilliary input connection provisions.
- DIN sized compartment for storage or for CB radio installation.

### DRIVER CONTROLS

- Key-operated engine start/stop and steering lock. Engine idle speed control.
- ASR on/off.
- DPD regeneration.
- AMT slow/fast gear engagement control, 1st gear start and normal/economy gear selection modes.
- **Left side combination stalk:** Windscreen wipers, washers and exhaust brake.
- **Right side combination stalk:** Turn signals and headlamps.
- PTO engage switch.
- Tip body raise and lower lever with safety release mechanism.

### INSTRUMENTATION

- Electronically driven speedometer and tachometer. Digital odometer with integrated dual tripmeter. Engine coolant temperature and fuel level gauges.
- **Warning lamps:** Check engine, oil pressure, ABS, SRS airbag, alternator charge, service brake failure, park brake, seat belt unfastened, low fuel level, check AMT.
- **Indicator lamps:** HSA, warm up system, high beam, ASR, DPD status, exhaust brake, turn signals, PTO engaged, econo-mode, 1st gear start.
- Gear selection display.

### OPTIONS AND GENUINE ACCESSORIES

Include the following (extra cost, request a brochure and further details from your Isuzu dealer):

#### Digital Audio Visual Entertainment unit:

- Isuzu satellite navigation including three years of free updates.
- Tyre pressure monitoring system.
- Cables for full iPod/iPhone/iPad compatibility and connection to other external audio visual devices.

#### Other:

- Airbag compatible bullbar.
- 3,500kg rated towbar.
- Air deflector.

## ISUZU CARE

Isuzu Care gives truck owners access to products and services including Roadside Assist, Service Agreements, Extended Care, Extended Isuzu Assist and the Isuzu Care Centre. Call 1800 035 640.

### WEIGHTS (kg)

Models	Ratings*		Loading Limit* (at ground)		Cab Chassis Mass #		
	GVM	GCM	Front	Rear	Front	Rear	Total
NQR 450 Tipper AMT	8,700	12,200	3,100	6,200	2,100	1,970	4,070

Maximum Gross Trailer Mass: 750 kg (unbraked), 3,500 kg (braked) \* Vehicle ratings and front/rear weight limits are subject to government regulatory requirements and weight distribution analysis. Consult your Isuzu dealer to select the correct vehicle for your specific application. # Cab chassis only as supplied and including 10 litres of fuel.

### DIMENSIONS (mm)

Models	WB	OAL	OAW	OAH	FOH	ROH	RT	ORT	CW	KERB TO KERB
NQR 450 Tipper AMT	3,365	5,870	2,360	2,280	1,110	1,285	1,670	2,150	1,995	12.4

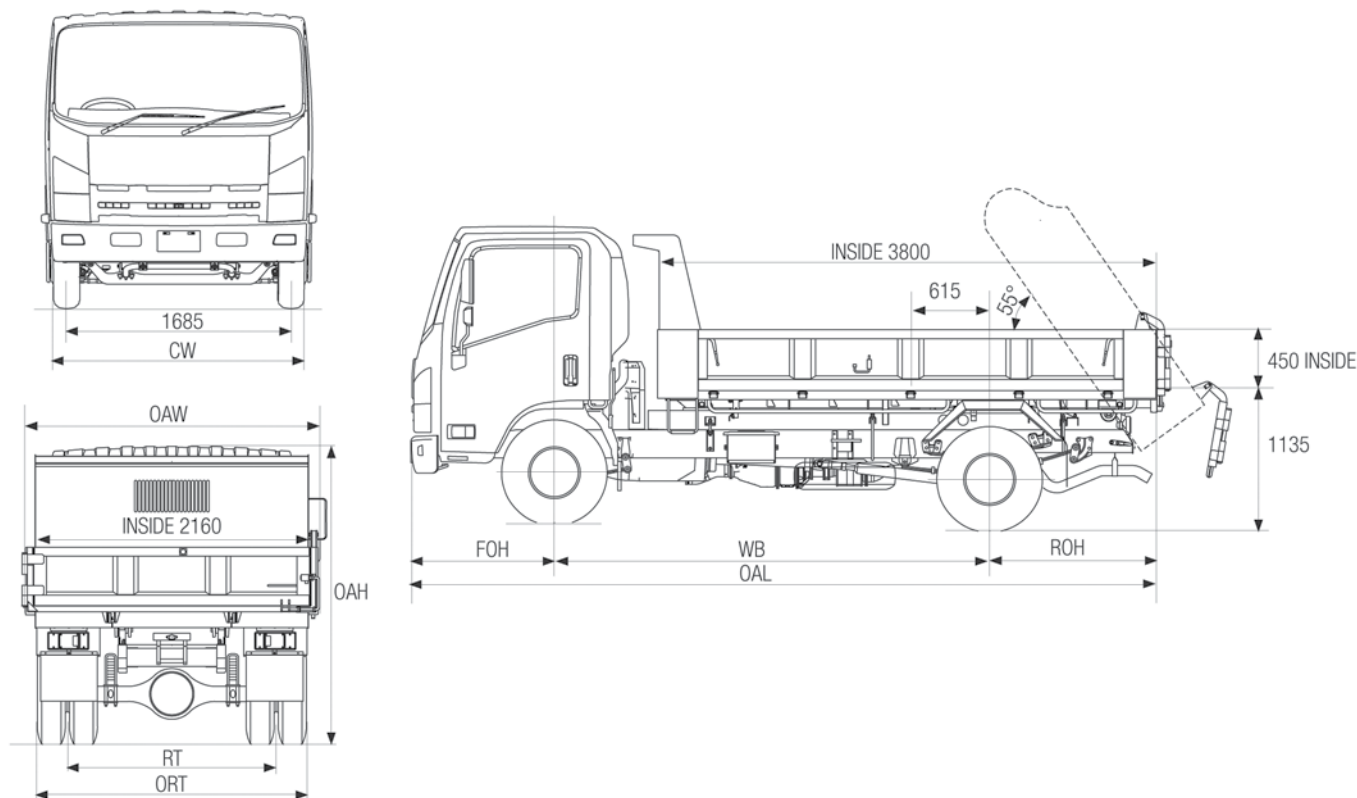

### PERFORMANCE (calculated - typical paved road)

	Geared Speed*	Low Speed Gradeability	Engine Speed
	(top gear at peak power engine RPM)	(lowest forward gear assuming no wheel slip)	(top gear at 100km/h)
NQR 450 Tipper AMT	At 8,700 kg GVM 116 km/h @ 2,600 RPM	37%	2,245 RPM

### ISUZU WARRANTIES

STANDARD <sup>1</sup>	
New Vehicle	3 years • 100,000km • 2,000 hours
Cab Perforation Corrosion	3 years • Unlimited km
Isuzu Assist: 24 hour roadside assistance (3 years, unlimited km's)*	
EXTENDED CARE <sup>2</sup>	
Extended Warranty: 5 years • 250,000km • 4,500 hours	
Isuzu Assist: 24 hour roadside assistance (5 years, unlimited km's)	

### ORDER CODES

Model	Code
NQR 450 Tipper AMT	NH-NQRZC-D13

<sup>1</sup> Subject to the conditions outlined in the IAL New Vehicle Warranty, the Isuzu NQR model carries a standard factory warranty which covers the owner: (i) for the entire vehicle, for the first 36 months or 100,000 km or 2,000 hrs (whichever comes first). (ii) against cab perforation corrosion, for 36 months and unlimited kilometres. <sup>2</sup> Extended Warranty as illustrated may be purchased to cover the owner against the failure of original components, but may exclude some components and expendable items such as oil, filters, etc. Please consult with your Isuzu Dealer for full details obtained from a dedicated brochure available to customers. \*Valid for three years from the date of new vehicle purchases. All Isuzu warranties are subject to mandatory prescribed terms under Australian Consumer law including customer guarantees. For more details visit the Isuzu website which explains Isuzu warranties in more detail, or alternatively contact your local dealer. All warranties commence from date of delivery.

ISUZU AUSTRALIA LIMITED ABN 97 006 962 572 ("IAL"). The information in this spec sheet was correct at time of printing, but all measurements, specifications and equipment are subject to change without notice. Some equipment may have been changed and/or is available at extra cost. IAL may make changes at any time without notice, in prices, colours, materials, equipment and models. IAL makes all reasonable attempts to ensure the availability of all vehicles and equipment. The information in this spec sheet is general in nature. Your Isuzu dealer can confirm all measurements, specifications and vehicle / equipment availability upon request. To the extent permitted by the law, IAL is not liable to any person as result of reliance on the content of this spec sheet.

January 2013. ARK0659



**ISUZU**  
RELIABILITY IS EVERYTHING