

# ISUZU NQR 450



**ISUZU**  
RELIABILITY IS EVERYTHING

## AT A GLANCE

GVM	8,500 kg
GCM	12,000 kg
Engine Type	Isuzu SiTEC 170
Displacement	4.8 L
Power	127 kW @ 2,700 rpm
Torque	458 Nm @ 2,000 - 2,400 rpm
Wheelbase	3,365 - 4,175 mm

# NQR 450

Medium / Long / Custom Long

## DRIVELINE & CHASSIS SPECIFICATIONS

### ENGINE: SITEC 170 (ISUZU 4HE1-XS)

Type: 4 cylinder, 4 stroke, SOHC, direct injection diesel.  
Turbocharged and air-to-air intercooled.  
Adjustable roller type rocker arms.  
Variable swirl system.

Displacement: 4,751 cc

Compression Ratio: 17.3:1

Bore x Stroke: 110 x 125 mm

Max power (DIN NET)/RPM: 127 kW @ 2,700 RPM

Max torque (DIN NET)/RPM: 458 Nm @ 2,000 - 2,400 RPM

Emissions Standard: ADR 80/00 (USEPA 1998)

- Plate type oil cooler. Oil capacity: 13.0 L. Combined full flow main filter and bypass oil filter.

### COOLING SYSTEM

- 6 blade, 440 mm diameter cooling fan with thermostatically controlled viscous clutch. Dual drive belts and thermostats. Radiator frontal area: 3,717 cm<sup>2</sup>. 12.5 L coolant capacity.

### AIR INTAKE SYSTEM

- Vertical air intake mounted on back of cab. 220 x 320 mm air cleaner element.
- 500 x 370 mm air-to-air intercooler.

### FUEL SYSTEM

- Zexel MI-TICS mechanically integrated in line injection pump. Fuel/water separator with warning lamp.
- 125 L steel tank.

### CLUTCH

- Self adjusting hydraulic control. Single plate. 325 mm diameter.
- Asbestos free lining material.
- Total lining area: 966 cm<sup>2</sup>

### TRANSMISSION

#### ISUZU MZZ-6U 6 Speed manual

- 6 forward speeds including overdrive.
- Synchromesh on all forward gears.
- 4.4 L oil capacity.
- PTO provision on LHS of transmission case. PTO drive from counter gear.
- Gear ratios (: 1)

1st	2nd	3rd	4th	5th	6th	Rev
6.369	3.767	2.234	1.442	1.000	0.782	6.369

### AXLES

#### FRONT: ISUZU FO31

- Reverse Elliot I-beam. 3,100 kg capacity.

#### REAR: ISUZU RO66

- Full floating Banjo type. Four differential pinions. 6,600 kg capacity.
- Drive ratio: 4.300:1

### SUSPENSION

#### FRONT

- Single stage, alloy steel, multi-leaf springs.
- Nominal size: 1,300 x 70 mm
- Total spring capacity (at ground): 3,630 kg
- Double acting, hydraulic shock absorbers. Stabiliser bar.

SITEC 170

Maximum Power : 127 kW @ 2,700 RPM

Maximum Torque : 458 Nm @ 2,000-2,400 RPM

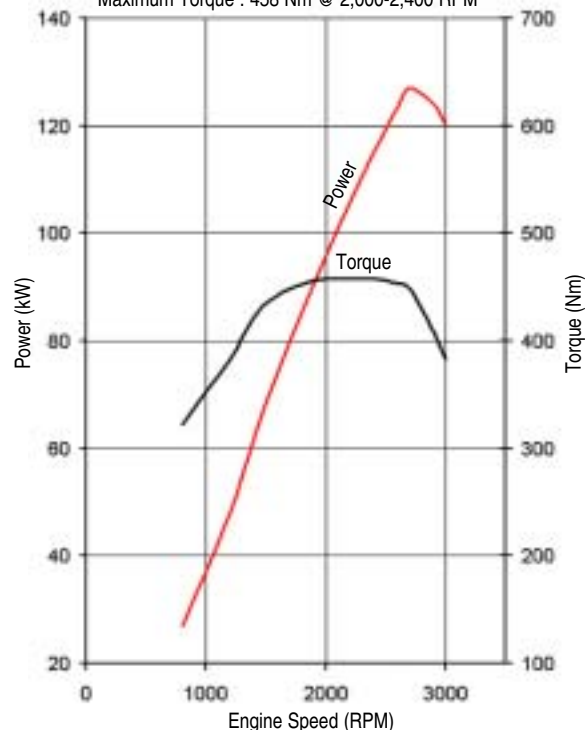

ISUZU SITEC 170 (4HE1-XS) ENGINE PERFORMANCE CHART

### REAR

- Two stage, alloy steel, multi-leaf springs.
- Nominal size: 1,350 x 70 mm
- Total spring capacity (at ground): 6,570 kg
- Double acting, hydraulic shock absorbers. Stabiliser bar.

### BRAKES

- Front and rear drum brakes with dual circuit hydraulic control, hydraulic pressure assistance and load sensing proportioning valve.
- Front drum diameter: 320 mm
- Rear drum diameter: 320 mm
- Swept area: 4,825 cm<sup>2</sup>
- Asbestos free lining material.
- 203 mm diameter drum park brake mounted on rear of transmission.
- Vacuum controlled exhaust brake.

### STEERING

- Power assisted recirculating ball steering.
- Gear ratio: 20.9:1
- Turns lock to lock: 4.9
- 42.5° wheel cut angle (inside wheel).

## WHEELS AND TYRES

- 6.00J x 17.5 Six stud wheels.
- 215/75R 17.5 Michelin XZE1 Tubeless tyres.
- Maximum tyre rating: 1,700 kg per tyre (single tyres).  
1,600 kg per tyre (dual tyres).
- 1 frame mounted spare wheel and tyre assembly.

## AXLE LOAD SUMMARY

	FRONT	REAR
Axle Capacity (kg):	3,100	6,600
Spring Capacity (kg):	3,630	6,570
Tyre Capacity (kg):	3,400	6,400
<b>Limit (kg):</b>	<b>3,100</b>	<b>6,400</b>

Note: Vehicle loading limit is determined by the combination of axle loading limit, GVM and GCM limit, and government regulatory requirements. Consult your Isuzu dealer to select the correct vehicle for your specific application.

## CHASSIS FRAME

- Cold riveted ladder frame. JIS-SAPH440 weldable steel. Parallel side rails and rivetless top flange.
- Frame dimensions  
Side rail (mm): 216 x 70 x 6.0  
Rear frame width (mm): 850

## ELECTRICAL SYSTEM

- 24 Volt electrical system.
- 24 Volt, 50 Amp alternator.
- 24 Volt, 4.5 kW starter motor.
- 2x 80D26R (582CCA) batteries connected in series.

# CABIN SPECIFICATIONS AND APPOINTMENTS

## CAB EXTERIOR

- All steel cab, side door impact protection beams. Outer body panels galvanised, corrosion resistant primer treated cab.
- Cab built to comply with ECE-R29 crash safety tests.
- Manual cab tilt to 45°.
- Access to fluid checkpoints without tilting cab.
- Four point tuned rubber cab mounting.
- Body coloured impact resisting polycarbonate front bumper, steel backing frame.
- Heavy duty aluminium non slip entry steps.
- 90° opening internally reinforced door.
- Water spray suppression guards, front mudflaps.
- Laminated windscreen.
- 2 speed windscreen wiper system, intermittent wipe mode, triple washer jets.
- Single piece halogen headlamps incorporating turn signals.
- Combination brake, turn, reverse and marker lamps, registration plate illumination lamps. Extended wiring harness. Reverse alarm.
- Roof-mounted clearance lamps.
- "West Coast" type rear view mirrors. Large flat mirror glass with additional, independently adjustable convex "spot" mirror on both sides.

## CAB INTERIOR

- Wide contoured driver's bucket seat, lumbar support, reclining back, fore-aft adjustment. Two person passenger bench seat, folding seat back. Seat tilts for access to engine. Durable, fire resistant cloth seat facing.
- 3-point, lap sash seatbelts with emergency locking belt retractors in all outboard seating positions.
- Door and "A" pillar entry assist grips.
- Full interior panel trim, padded roof lining, vinyl floor mats. Windscreen header storage shelf.
- Tilt/Telescopic adjustable steering column, soft feel urethane steering wheel.
- Electric windows.
- Central locking with remote keyless entry.
- Twin cup holders.

- Centre console box with two storage trays. Fold down storage tray behind centre seat backrest.
- Heater/Demister with 4-speed fan and outlets for windscreen, side windows, face and floor.
- Fore-aft adjustable roof vent.
- Standard fully integrated air conditioning.
- Interior lamp with On/Door/Off switch activated by either door.
- Two speaker Eurovox Radio/CD player with digital anti skip memory.
- Optional 10 stack CD player.
- DIN sized compartment below radio for storage or for CB radio installation.

## DRIVER CONTROLS

- Key-operated engine start/stop and steering lock. Engine idle speed control.
- Left side combination stalk: Windscreen wipers, washers and exhaust brake.
- Right side combination stalk: Turn signals and headlamps.

## INSTRUMENTATION

- Gauges: Electronically driven speedometer and tachometer. Digital odometer with integrated dual tripmeter. Engine coolant temperature and fuel level gauges.
- Warning lamps: Low battery charge, brake failure, low fuel level, glow plug/engine malfunction, low oil pressure, water separator.
- Indicator lamps: Turn signals, parking brake, high beam, exhaust brake engaged.

## CUSTOM CAB MODEL (LONG WHEELBASE ONLY) FEATURES REPLACING OR ADDITIONAL TO STANDARD CAB FEATURES

- Chrome radiator grille and headlamp surrounds.
- Gold "Custom" badging and emblem. Gold ISUZU badge.
- Distinctive trim throughout.
- "Shukra" brand driver seat with adjustable lumbar support and headrest. Adjustable passenger headrest.
- Carpet floor covering.
- Bumper mounted foglamps.

# NQR 450

## Medium / Long / Custom Long

8NV02-NSM

8NV02-NS1

8NV02-NSC

### PERFORMANCE (Calculated)

NQR 450	
Max Geared speed:	127 km/h @ 3,000 rpm
Gradeability (lowest gear):	36% at 8,500 kg GVM
Gradeability (top gear at 100 km/h):	0.6% (2.5 x 2.6 m van body at 8,500 kg GVM)
Engine speed (top gear at 100 km/h):	2,370 rpm

Performance figures quoted are representative only and based on typical dimensions, body styles and weights. Please consult your Isuzu dealer for an estimation based on your specific application.

### MODEL RATINGS AND DIMENSIONS

MODELS	RATINGS (kg)		TARE MASS <sup>#</sup> (kg)			DIMENSIONS (mm)												TURN CIRCLE KERB TO KERB
	GVM	GCM	TOTAL	FRONT	REAR	WB	OAL	FOH	ROH	CA	CE	RT	ORT	CH	CW	FFH LADEN	RFH LADEN	
Medium	8,500	12,000	2,620	1,710	910	3,365	5,955	1,085	1,505	2,840	4,345	1,650	2,115	2,265	1,995	685	795	12.4 m
Long/Custom	8,500	12,000	2,675	1,755	920	4,175	7,320	1,085	2,060	3,650	5,710	1,650	2,115	2,260	1,995	685	795	14.8 m

**TOWING CAPACITY** • Unbraked trailer: 750 kg • Braked trailer: 3,500 kg

<sup>#</sup> Estimated mass of cab/chassis with oil, water and fuel tank containing 10 litres of fuel and including spare wheel and tools.

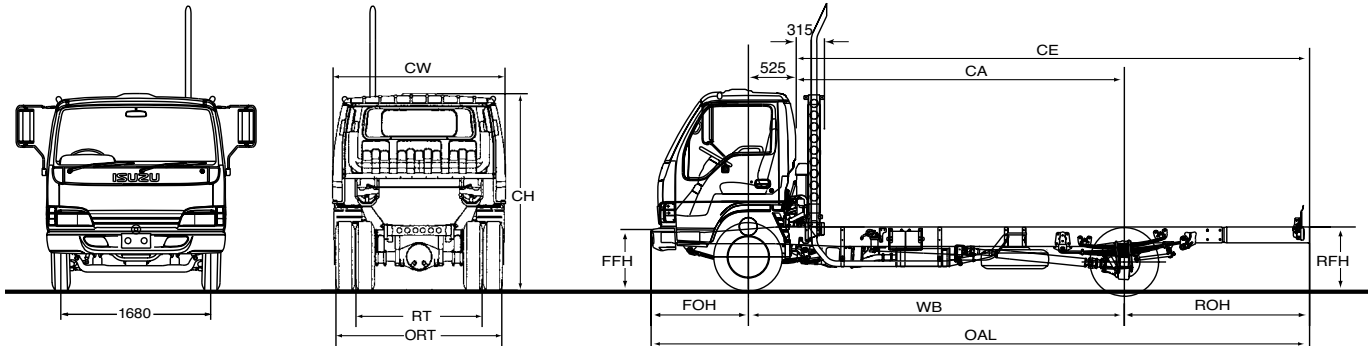

For further information regarding Cab/Chassis dimensions your Isuzu Dealer can access detailed Body Builders diagrams from the Isuzu Truck Technical Reference CD.

### ISUZU NEW TRUCK WARRANTIES

STANDARD TRUCKPOWER WARRANTY*			TRUCKPOWER EXTENDED WARRANTY OPTIONS <sup>#</sup>		
NEW VEHICLE	3 years	100,000 km	4 years / 200,000 km	5 years / 250,000 km	6 years / 300,000 km
DRIVETRAIN	3 years	100,000 km			
CAB CORROSION	3 years	unlimited			

#### Why have Isuzu Trucks been Australia's No. 1 choice since 1989? \*

- Widest range of models to suit most applications
- Premium componentry and Isuzu diesel engines
- Network of over 40 specialist Isuzu Dealerships and branches
- Sales, services and parts support
- Predictable operating costs through Dealer ISIS program
- Factory and range of extended warranties available
- High resale values
- Leading reputation for reliability

[www.isuzu.com.au](http://www.isuzu.com.au)

\* Source Truck Tracker 2002

\* Subject to the conditions outlined in the I-GM New Vehicle Warranty, the Isuzu NQR models carry a standard factory warranty which covers the owner: (i) for the entire vehicle, for the first 36 months or 100,000 km (whichever comes first). (ii) for the drivetrain, which runs concurrently, for 36 months or 100,000 km (whichever comes first). (iii) against cab corrosion, for 36 months and unlimited kilometres.

<sup>#</sup> A TruckPower Extended Warranty as illustrated is available by purchase to cover the owner against the failure of original components, but excludes some components and expendable items such as oil, filters, etc. Please consult with your Isuzu Dealer for full details obtained from a dedicated brochure available to customers.

ISUZU-GENERAL MOTORS AUSTRALIA LTD A.C.N. 006 962 572. PLEASE NOTE: as the policy of I-GM is one of continual product improvement, all specifications and equipment are subject to change without notice. No I-GM dealer or other person is authorised or permitted to give or make any statement, assertion or undertaking in relation to the quality, performance, characteristics, descriptions or fitness for any purpose of any I-GM product or in connection with the supply of any I-GM product which is at variance with any written statement, assertion or undertaking on any of these subjects given or made by I-GM in its published sales literature, and the company accepts no liability for any such unauthorised action. I-GM has franchised dealers in many parts of Australia, for the sale of service, parts and the provision of service to the owners of I-GM products. Every endeavour is made to ensure that such dealers carry adequate stocks of service parts and are equipped to provide satisfactory service, but makes no promise, other than that contained in the I-GM new vehicle warranty, that such parts or service facilities will be available or available at any specific location or at any particular time. A word about this specification sheet. We have tried to make it as comprehensive and factual as possible. However, since the time of printing some of the information you will find here may have been updated. Also, some of the equipment shown or described through this specification sheet may have been changed and/or is available at extra cost. And the right is reserved to make changes at any time without notice, in prices, colours, materials, equipment and models. Your I-GM dealer has details and before ordering, you should ask him/her to bring you up to date.

SEPTEMBER 2003. ARK/GM 0085

# ISUZU

**RELIABILITY IS EVERYTHING**