

700

FTS 700 4 x 4

GVM: 12,500kg
*GCM: 15,000/18,000kg
WHEELBASE: 4,200mm

ISUZU 6BG1 ENGINE PERFORMANCE

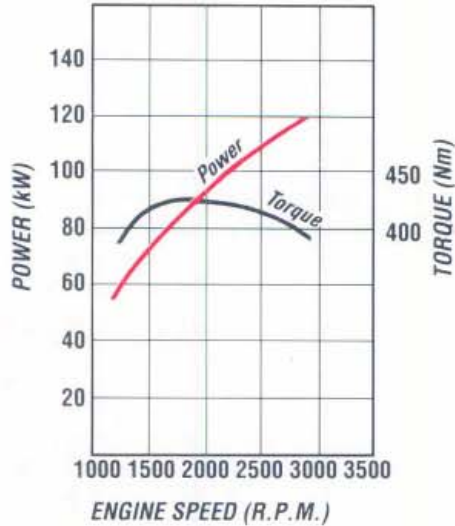

- Type: 6 cylinder OHV diesel, four stroke, direct injection
- Bore x Stroke (mm) 105 x 125
- Displacement 6494 (cc)
- Compression Ratio (:1) 17.0
- Output-Power (kW) 120 @ 2900 rpm (DIN Nett)
- Torque (Nm) 431 @ 1800 rpm (DIN Nett)

DIMENSIONS AND WEIGHTS

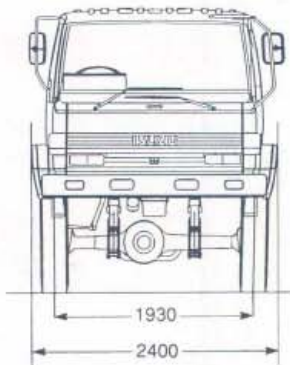
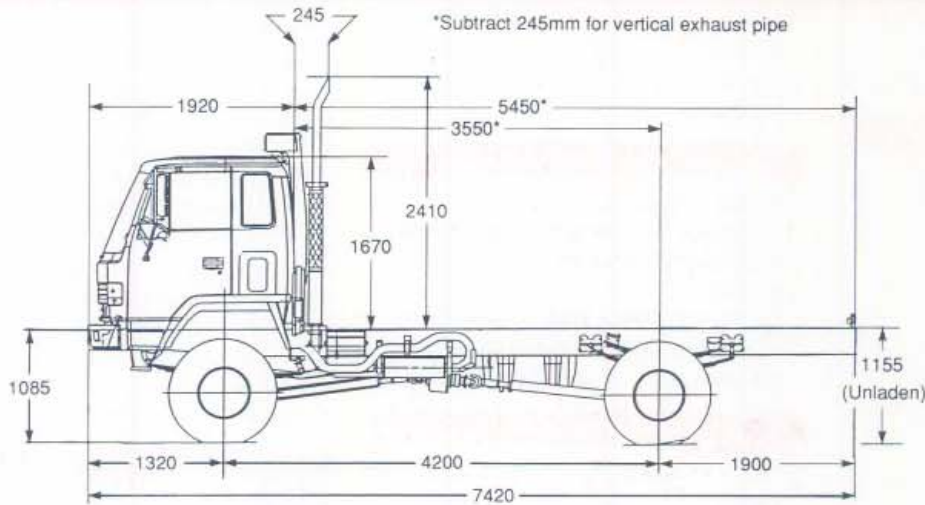

*ESTIMATED KERB MASS (kg)	
FRONT	2734
REAR	1758
TOTAL	4492
FRAME WIDTH (mm)	850
TURNING CIRCLE (m)	
Kerb to Kerb	18.0
BODY LENGTH (mm)	5480
Subject to weight distribution	

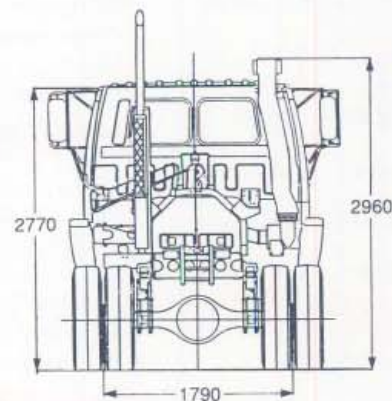

*Chassis and cab with oil, water and fuel tank containing 10 litres of fuel.
*15,000kg off road 18,000kg on road

ISUZU-GENERAL MOTORS AUSTRALIA LTD A.C.N. 006 962 572

12/50 WARRANTY. Every Isuzu Truck is covered by the I-GM new vehicle warranty which covers your vehicle for the first 12 months or 50,000 kilometres.

PLEASE NOTE: as the policy of Isuzu-General Motors Australia Motors is one of continual product improvement, all specifications and equipment are subject to change without notice. Body illustrated are not standard. No I-GM dealer or other person is authorised or permitted to give or make any statement, assertion or undertaking in relation to the quality performance characteristics descriptions or fitness for any purpose of any I-GM product or in connection with the supply of any I-GM product which is at variance with any written statement assertion or undertaking on any of these subjects given or made by Isuzu-General Motors Australia Limited in its published sales literature, and the company excepts no liability for any such unauthorised action. Isuzu-General Motors Australia Limited has franchised dealers in many parts of Australia. For the sale of service parts and the provision of service to owners of I-GM products. Every endeavour is made to ensure that such dealers carry adequate stocks of service parts, and are equipped to provide satisfactory service, but makes no promise, other than that contained in the New Vehicle Warranty given by Isuzu-General Motors Australia Limited, that such parts or service facilities will be available, or available at any specific location or any particular time.

CT2924-2/92

ISUZU





700

FTS 700 4 x 4

ORDERING CODE:
8EW02-521

ENGINE - ISUZU 6BG1

Lubrication:

- Pressure feed lubrication with full flow, paper element filter, oil cooler. Oil capacity 12.5 litres including filter.

Cooling System:

- Six blade plastic cooling fan, with thermatic clutch. Size 475 mm diameter.
- Tube and corrugated fin pressure type radiator size (mm) 622h x 559w x 53t, frontal area 0.348m² with bell mouth fan shroud.

FUEL SYSTEM

- Two stage paper element air cleaner, Donaldson 11" with high vertical air intake stack and rain head.
- In line plunger, Bosch 'A' type fuel injection pump with mechanical all speed governor.
- In line paper filter, see-through water separator with drain cock.
- Fuel tank capacity 200 litres.
- Horizontal exhaust muffler with vertical stack.

CLUTCH

- Hydraulic control, dry single plate with coil type cushioning springs. 350 mm (14") diameter, lining area 1164cm² (Both sides.)

TRANSMISSION - ISUZU MLD6D

- Six speed direct drive, constant mesh, synchromesh on gears 2-6. Oil capacity 6.5 litres.

Gear Ratios:1

1st	7.166
2nd	4.526
3rd	2.919
4th	1.954
5th	1.254
6th	1.000
Reverse	7.276

- Maximum geared speed 106 km/h
- Two speed transfer case, oil capacity 3 litres.

Ratios : 1

High - 1.000 Low - 2.091

- Three piece propeller shaft

	Diameter	Length
Transmission to transfer case	50mm	144mm
Transfer case to front axle	90mm	1,404.6mm
Transfer case to rear axle	90mm	1,317.5mm

REAR AXLE - CAPACITY 9,200kg

- Banjo type, fully floating, with no spin differential. Ratio 5.571:1
- Hypoid type ring gear, 398mm diameter Oil capacity 7.5 litres

REAR SUSPENSION - CAPACITY 14,600kg

- Semi elliptical, alloy steel, tapered, multi leaf springs. Fully wrapped eye with greasable shackles.

- Size: Length x width x thickness
Main: 1420 x 80 x 12mm - 1 leaf
1420 x 80 x 13mm - 6 leaves
Auxiliary: 1000 x 80 x 12mm - 9 leaves

FRONT AXLE CAPACITY - 4,700kg

- Banjo type, fully floating with Birfield type steering ball joint. Ratio 5.571:1
- Spiral bevel type ring gear, 365mm diameter Oil capacity 3.8 litres.

FRONT SUSPENSION - CAPACITY 7,500kg

- Semi elliptical, alloy steel, tapered, multi leaf springs. Fully wrapped eye with greasable shackles.
- Size: Length x width x thickness
1470 x 80 x 12 - 3 leaves
1470 x 80 x 13 - 4 leaves
1470 x 80 x 18 - 1 leaf
- Hydraulic, double acting, telescopic shock absorbers.

STEERING

- Fully integral, power assisted, recirculating ball type. Gear ratio :1 16.1-18.8 variable Turns lock to lock 4.6
- Gear driven vane type oil pump, oil capacity 2.0 litres.

BRAKES

- Air over hydraulic, dual circuit, front two leading, rear dual two leading, drum diameter front 400mm, rear 410mm. Total lining area 4210 cm².
- Spring parking brake acting on rear wheels.
- Butterfly, air controlled, exhaust brake system, activation switch on wiper/washer control stalk.

CHASSIS FRAME

- Parallel rail, ladder type, channel section, cold riveted.
- Side member dimensions 253 x 80 x 7.5mm
- Frame reinforcement 240 x 72.5 x 4.5mm at back of cab.
- High tensile steel, HT55 weldable frame material.

WHEELS AND TYRES

- 7.00T x 20 - 8 stud disc wheels front and rear. 20mm bolt size.
- 9.00R 20 - 14 ply Dunlop GB127 tubed radial tyres front and rear.
- Number of tyres 7, including spare.
- Tyre inflator hose and fitting.
- Winch type spare wheel carrier.

ELECTRICAL SYSTEM

- Batteries 2 x 12 Volt - 55 amp/hour, negative earth.
- Alternator 24 Volt - 40 amp.
- Starter motor 24 Volt - 4.5kW output.
- Rear stop and tail lamps and licence plate lamp with long leads for variable body mounting.

CAB EXTERIOR

- All steel cab, manual tilt to 45°. Cation electro deposition primer. Torsion bar counter balanced.
- Heavy duty bumper bar with four rectangular halogen headlamps inset.
- Access to engine fluid checks without tilting cab.
- Combination turn signal and park lamps.
- West Coast type rear view mirrors with clearance lamps.
- Laminated windshield, 2 speed wiper with intermittent mode and washers.
- Front and rear quarter vent windows.
- Corrosion resistant, non slip cab entry steps.
- Tool kit with 10,000kg capacity jack.

CAB INTERIOR

- Fully trimmed cab interior, cloth seat facings, formed roof lining and overhead parcel shelf with driver and passenger sunvisors.
- ISRI 5000 driver's seat with mechanical suspension, adjustment for seat back recline, seat slide and height control.
- Outboard passenger seat, folding centre seat back with lockable compartment and snack tray.
- Outboard lap/sash seat belts with emergency locking retractor, inboard lap seat belt.
- Tilt telescopic adjustable steering column, soft feel urethane steering wheel.
- Easy entry grab handles on 'A' and 'B' pillars.
- Heater demister with 4 speed fan, 4 outlet vents to screen, 5 fascia outlets, 5 foot outlets.
- AM/FM radio with digital clock, dash mounted.
- High low ratio selector, and 4 wheel drive selector.

INSTRUMENTATION

- Speedometer, odometer and tachometer.
- Gauges for coolant temperature, fuel level and brake air pressure.
- Dash illumination control.

INDICATOR LAMPS

- Turn signals, parking brake on, high beam on, exhaust brake engaged, brake fluid level, four wheel drive engaged.

WARNING LAMPS

- With warning bulb check switch.
- Battery charge, oil filter clogged, oil pressure, low air pressure, brake system, air cleaner clogged, stop and tail lamp failure.

SWITCHES

- Left side combination switch for exhaust brake, wipers and washers.
- Hazard lamp switch.
- Right side combination switch for headlamps, turn signals and headlamp dip.
- Key operation for engine stop and start, external engine crank switch for service when cab is tilted.
- 24 Volt 2 pin accessory plug on centre fascia panel.
- Three way switch for interior lamp, activated by driver and passenger doors.