

# ISUZU

SPECIFICATIONS

**NEW**  
NEW GENERATION ISUZU  
**GEN**

## FRR 500

## Tipper



AUSTRALIA'S TOP SELLING TRUCK BRAND SINCE 1989. Truck tracker 2007.

### AT A GLANCE

<b>GVM</b>	10,400 kg
<b>GCM</b>	16,000 kg
<b>Power</b>	154 kW @ 2,600 rpm
<b>Torque</b>	637 Nm @ 1,600 - 2,600 rpm

### UPGRADE OPTIONS

#### AMT Pack:

- Automated Manual Transmission (AMT)
- Instrument panel multi-information display
- Cruise control

### ADVANCED TECHNOLOGY

- Driver airbag with seatbelt pretensioner
- Anti-lock Braking System (ABS)
- Anti Skid Regulator (ASR)
- Hill Start Aid (HSA)
- Electric mirrors
- Front stabiliser bar
- ISRI 6860 seat with integrated seatbelt

RELIABILITY IS EVERYTHING **ISUZU**

## Driveline & Chassis Specifications

### ENGINE: SITEC SERIES II 205 (ISUZU 4HK1-TCS)

- Type:** 4 cylinder 16 valve SOHC
- Displacement:** 5,193 cc
- Compression Ratio:** 17.5:1
- Bore x Stroke:** 115 mm x 125 mm
- Max power** (DIN-NET): 154 kW (207 HP) @ 2,600 RPM  
(JIS Gross): 160 kW (214 HP) @ 2,600 RPM
- Max torque** (DIN-NET): 637 Nm (470 lb.ft) @ 1,600 - 2,600 RPM  
(JIS Gross): 659 Nm (486 lb.ft) @ 1,600 - 2,600 RPM
- Induction system:** Electronically controlled variable nozzle turbocharger with air-to-air intercooler.
- Fuel injection:** Direct injection high pressure common rail system.
- Emission control system:** Two-stage electronically controlled cooled EGR with exhaust Diesel Particulate Diffuser (DPD). ADR 80/02 (Euro IV) compliant.

### CLUTCH

#### MQ Model:

- Air assisted hydraulic control. Single plate 352 mm diameter.
- Total lining area: 1,164 cm<sup>2</sup>

#### AMT Pack:

- Fully automated hydraulically controlled wet clutch and fluid coupling with lock up.

### TRANSMISSION

#### Isuzu MZX-6P (except MQ model)

- 6 speed Automated Manual Transmission (AMT) with both fully automatic and clutchless manual operation modes.
- Synchromesh on gears 2-6. Triple cone synchromesh on 2nd and 3rd gears. Integral oil pump provides full pressure lubrication.

#### Gear ratios (: 1)

1st	2nd	3rd	4th	5th	6th	Rev
6.615	4.095	2.358	1.531	1.000	0.722	6.615

#### Isuzu MLD-6Q (MQ model)

- 6 speed manual with air assisted shift.
- Synchromesh on gears 2-6.

#### Gear ratios (: 1)

1st	2nd	3rd	4th	5th	6th	Rev
6.720	4.244	2.580	1.540	1.000	0.763	6.823

### AXLES

#### Front: Isuzu F041

- Reverse Elliot I-beam. 4,100 kg capacity.

#### Rear: Isuzu R077

- Full floating Banjo type. 7,700 kg capacity.
- Drive ratio: 5.125:1

### SUSPENSION

#### Front:

- Single stage alloy steel multi leaf springs.
- Double acting hydraulic shock absorbers. Stabiliser bar.

#### Rear:

- Multi leaf main spring, multi leaf helper spring.

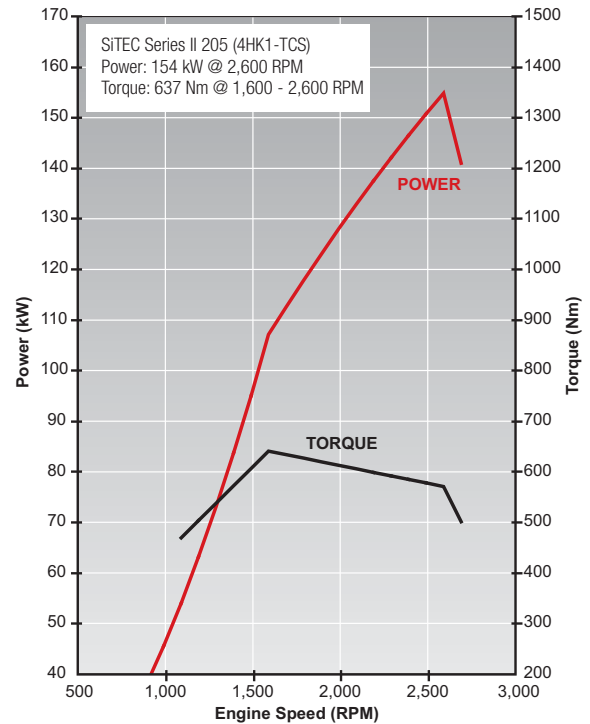

### BRAKES

- Dual circuit air over hydraulic front and rear drum brakes.
- ABS.
- ASR traction control.
- Hill Start Aid (HSA).
- Front drum size: 320 x 120 mm
- Rear drum size: 320 x 145 mm
- Spring park brake.
- Air controlled exhaust brake.
- Air dryer.

### STEERING

- Power assisted recirculating ball steering.
- Gear ratio: 16:1 - 18.8:1
- Turns lock to lock: 4.1
- Maximum angle: 52° (inside wheel) / 39° (outside wheel)

### WHEELS AND TYRES

- 17.5 x 6.00J six stud steel wheels.
- **Steer axle:** 9.5R17.5 129/127L Michelin XZA Tubeless
- **Drive axle:** 9.5R17.5 129/127L Michelin XZT Tubeless
- Maximum tyre rating:  
Steer axle: 3,700 kg  
Drive axle: 7,000 kg
- Spare wheel and tyre assembly supplied.

## CHASSIS FRAME

- Cold rivetted ladder frame with parallel side rails. HT540A high tensile weldable steel sidemembers.
- Frame dimensions:
  - Side rail (mm): 225 x 70 x 6.0
  - Rear frame width (mm): 840

## TIPPER BODY

- All steel body with drop sides. Auto release two-way tailgate.
- Auto release body lockdown hook.
- Shovel rack. LHS and RHS rope rails. Non-slip side steps.
- 20 second raise / 20 second lower time.
- Cubic volume: 3.8 m<sup>3</sup>

- Deck plate thickness: 6.0 mm
- Side / front / tail plate thickness: 3.2 mm

## FUEL TANK

- Frame mounted 200L steel fuel tank.
- Lockable fuel cap.

## ELECTRICAL SYSTEM

- 24 volt electrical system.
- 60 amp alternator.
- 24 Volt, 4.5 kW starter motor.
- 2 x 80D26L (630 CCA) batteries connected in series.

## Cabin Specifications and Appointments

### CAB EXTERIOR

- All steel construction. High tensile steel used for cab underframe. Manual cab tilt to 45° with torsion bar assistance.
- Liquid filled front and rear cab mounts.
- Heavy duty non slip entry steps.
- 90° opening internally reinforced front doors.
- Water spray suppression guards and front mudflaps.
- Laminated windscreen with shade band.
- Two speed windscreen wipers, with intermittent wipe mode.
- Halogen multi-reflector headlamps incorporating turn signals. Additional door mounted side indicator lamps.
- Combination brake, turn, reverse and marker lamps, registration plate illumination lamps. Reverse alarm.
- Heated and powered exterior main mirrors with flat glass and additional powered convex "spot" mirrors.
- Body coloured grille.
- Body coloured steel bumper with front foglamps.

### CAB INTERIOR

- Isri 6860 air suspension driver's seat with pneumatic lumbar support, height, rake and automatic weight adjustment.
- Front passenger adjustable bucket seat and front centre seat with folding seat back.
- 3-point lap sash seatbelts in all outboard seating positions. Driver seatbelt with pre-tensioner integrated with driver seat. Centre seat lap belts.
- Driver airbag.
- **AMT Pack:** Driver's footrest.
- Door and roof pillar entry assist grips.
- Full interior trim, padded roof lining and vinyl floor covering. Driver and passenger windscreen header storage shelf.
- Tilt/Telescopic adjustable steering column, soft feel urethane steering wheel.
- Electric windows.
- Central locking with remote keyless entry and immobiliser.
- Twin cup holders. 24V cigarette lighter. Dashboard hook.
- Front door mounted storage pockets and driver's side ashtray.
- Centre console box with storage tray. Fold down storage tray behind centre seat backrest.
- Front passenger glovebox.
- Fully integrated air conditioning and heater/demister with 4-speed fan and

- outlets for windscreen, side windows, face and floor.
- Fluorescent type interior lamp with On/Door/Off switch.
- Two speaker radio/CD player with clock.
- DIN sized compartment for storage or for CB radio installation.

### DRIVER CONTROLS

- Key-operated engine start/stop and steering lock. Engine idle speed control.
- HSA slow/fast engagement control and on/off switch.
- ASR on/off.
- DPD regeneration.
- **Left side combination stalk:** Windscreen wipers, washers and exhaust brake.
- **Right side combination stalk:** Turn signals and headlamps. **AMT Pack:** Cruise control.
- **AMT Pack:** AMT slow/fast gear engagement control, 1st gear start and normal/economy gear selection modes.
- PTO engage switch.
- Tip body raise and lower lever with safety release mechanism.

### INSTRUMENTATION

- Electronically driven speedometer and tachometer. Digital odometer with integrated dual tripmeter. Engine coolant temperature, fuel level and air pressure gauges.
- **Warning lamps:** Check engine, oil pressure, ABS, SRS airbag, alternator charge, service brakes, park brake, seat belt unfastened, low air pressure, low fuel level, cab lock. **AMT Pack:** Check AMT.
- **Indicator lamps:** HSA, warm up system, high beam, ASR, DPD status, exhaust brake, turn signals, PTO engaged. **AMT Pack:** Cruise control, econo-mode, 1st gear start.
- **AMT Pack:** Gear selection display.
- **AMT Pack:** Multi-information display. Shows service interval, instantaneous and average fuel consumption, DPD bar chart, hourmeter, voltmeter, time/day/date and includes 40-120 km/h adjustable vehicle speed warning.

### OPTIONS AND GENUINE ACCESSORIES

Include the following (extra cost, check with dealer for availability):

- Radio/CD multimedia unit.
- Radio/CD multimedia unit and module for Bluetooth/iPod input/SD card reader.
- Radio/CD multimedia unit and module for Bluetooth/iPod input/SD card reader/satellite navigation (includes NAVTEQ mapping).
- Airbag compatible bullbar.
- Cloth seat covers.

### Weights (kg)

Models	Ratings*		Loading Limit* (at ground)		Cab Chassis Mass#		
	GVM	GCM	Front	Rear	Front	Rear	Total
FRR 500 Tipper MQ	10,400	16,000	3,700	7,000	2,385	2,115	4,500
FRR 500 Tipper AMT	10,400	16,000	3,700	7,000	2,410	2,120	4,530

\* Vehicle ratings and front/rear weight limits are subject to government regulatory requirements and weight distribution analysis. Consult your Isuzu dealer to select the correct vehicle for your specific application.

# Cab chassis only as supplied and including 10 litres of fuel.

### Dimensions (mm)

Models	WB	OAL	OAW	OAH	FOH	ROH	RT	ORT	CW	Turn Circle (m)	
										KERB	TO KERB
FRR 500 Tipper	3,784	6,255	2,360	2,520	1,157	1,205	1,660	2,152	2,200	12.0	

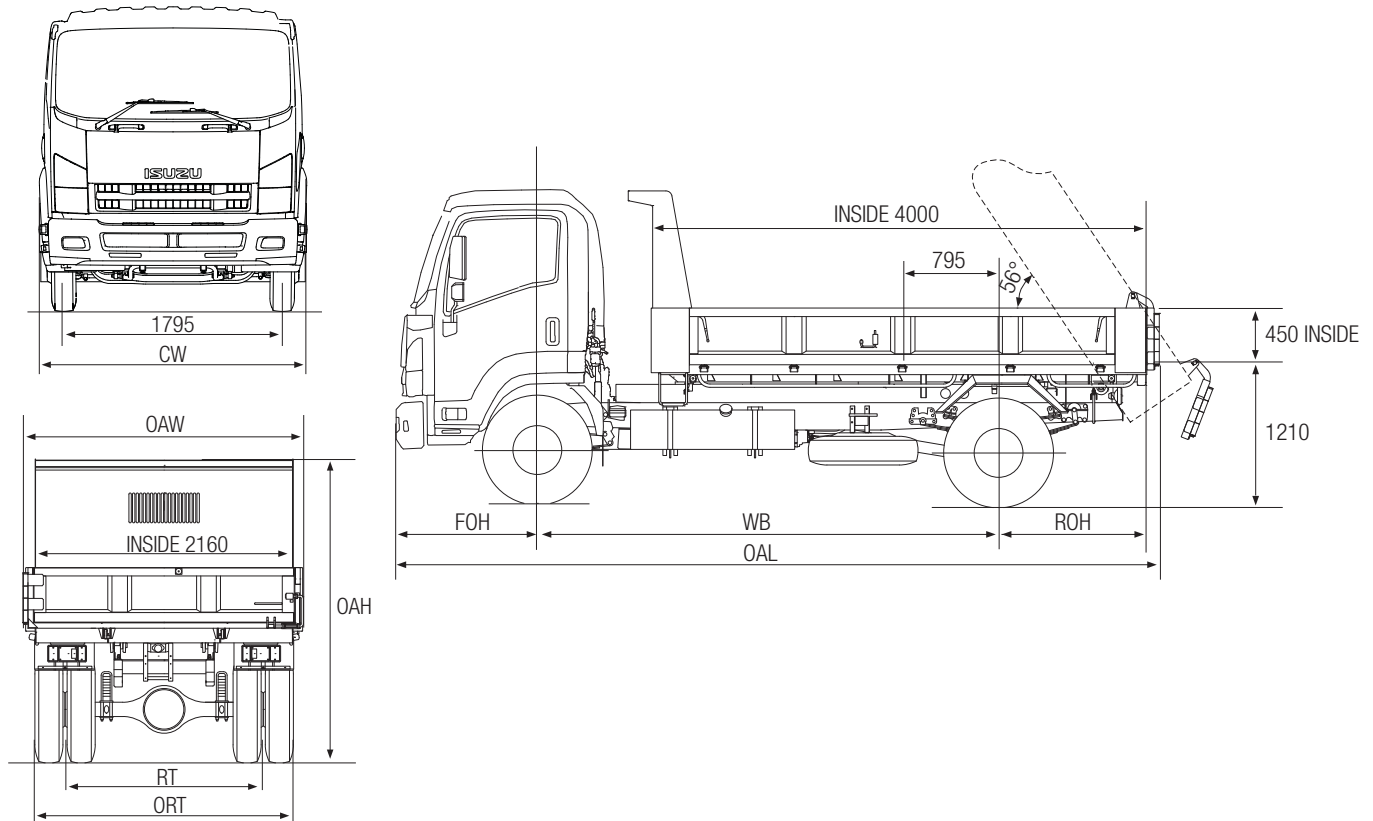

### Performance (calculated - typical paved road)

		Geared Speed* (top gear at peak power engine RPM)	Low Speed Gradeability (lowest forward gear assuming no wheel slip)	Engine Speed (top gear at 100 km/h)
FRR 500 Tipper MQ	At 10,400 kg GVM	103 km/h @ 2,600 RPM	47%	2,530 RPM
FRR 500 Tipper AMT Pack	At 10,400 kg GVM	109 km/h @ 2,600 RPM	46%	2,395 RPM

\* Maximum speed achievable depends on vehicle frontal area as well as other factors. Consult your Isuzu dealer for more detailed information.

### Isuzu Warranties

#### STANDARD<sup>1</sup>

New Vehicle	3 years   150,000 km   2,500 hrs
Cab Perforation Corrosion	3 years   Unlimited km

#### EXTENDED<sup>2</sup>

4 years   250,000 km	5 years   300,000 km	6 years   350,000 km
----------------------	----------------------	----------------------

<sup>1</sup> Subject to the conditions outlined in the IAL New Vehicle Warranty, the Isuzu FRR model carries a standard factory warranty which covers the owner: (i) for the entire vehicle, for the first 36 months or 150,000 km or 2,500 hrs (whichever comes first). (ii) against cab perforation corrosion, for 36 months and unlimited kilometres. <sup>2</sup> Extended Warranty as illustrated is available by purchase to cover the owner against the failure of original components, but may exclude some components and expendable items such as oil, filters, etc. Please consult with your Isuzu Dealer for full details obtained from a dedicated brochure available to customers.

ISUZU AUSTRALIA LIMITED ABN 97 006 962 572 ("IAL"). The information in this brochure was correct at time of printing, but all measurements, specifications and equipment are subject to change without notice. Some equipment may have been changed and/or is available at extra cost. IAL may make changes at any time without notice, in prices, colours, materials, equipment and models. IAL makes all reasonable attempts to ensure the availability of all vehicles and equipment. The information in this brochure is general in nature. Your Isuzu dealer can confirm all measurements, specifications and vehicle / equipment availability upon request.

July 2008. ARK0328