



ISUZU

FVR 950

FVD 950

9 Speed



ISUZU

ASSIST

24 hour (3 year) Isuzu Assist program standard on all new Isuzu F Series models (refer to your Isuzu Dealer for details).

AT A GLANCE

GVM	16,500 kg
GCM	26,000 kg
Engine Type	Isuzu SiTEC 255
Displacement	7.8 L
Power	191 kW @ 2,500 rpm
Torque	745 Nm @ 1,500 rpm
Wheelbase	4,250 - 6,250 mm

DRIVELINE & CHASSIS SPECIFICATIONS

ENGINE: SITEC 255 (ISUZU 6HK1-TCS)

Type: 6 cylinder, 4 stroke, 24 valve, SOHC, direct injection diesel. Turbocharged and air-to-air intercooled. Adjustable roller type rocker arms.

Displacement: 7,790 cc

Compression Ratio: 16.8:1

Bore x Stroke: 115 x 125 mm

Max power (DIN NET): 191 kW (256 HP) @ 2,500 RPM

Max torque (DIN NET): 745 Nm (549 lb.ft) @ 1,500 RPM

Emissions Standard: ADR 80/00 (Euro III)

- Plate type oil cooler. 13.5 L oil capacity. Combined full flow main filter and bypass oil filter.

COOLING SYSTEM

- 8 blade, 640 mm diameter cooling fan with thermostatically controlled viscous clutch. Dual drive belts and thermostats. Radiator frontal area: 5,088 cm². 23 L coolant capacity.

AIR INTAKE SYSTEM

- Vertical air intake mounted on back of cab. Two stage Donaldson air cleaner with 280 x 380 mm main element and 160 x 350 mm secondary element.
- 540 x 580 mm air-to-air intercooler.

FUEL SYSTEM

- Zexel MD-TICS in line injection pump. Separate fuel filter and water separator.
- 180 L steel tank.

CLUTCH

- Air assisted hydraulic control. Single plate 381 mm diameter. Asbestos free cerametallic lining material. Total lining area: 1,363 cm²

TRANSMISSION

EATON FS-8209A BBE 9 Speed manual

- 9 forward speeds. Direct drive.
 - Syncromesh on gears 1-8. Repeat 'H' shift pattern.
 - 8.5 L oil capacity.
 - Two SAE PTO openings on LHS of transmission case.
 - Gear ratios (: 1)
- | | | | | | | | | | |
|-------|------|------|------|------|------|------|------|------|-------|
| Low | 1st | 2nd | 3rd | 4th | 5th | 6th | 7th | 8th | Rev |
| 12.64 | 8.81 | 6.55 | 4.77 | 3.55 | 2.48 | 1.85 | 1.34 | 1.00 | 13.17 |

AXLES

FRONT: MERITOR FG941

- Reverse Elliot I-beam. 6,600 kg capacity.
- Oil bath lubricated front wheel hubs, see through oil level indicator.

REAR: MERITOR RS-23-161G

- Full floating Banjo type. 10,400 kg capacity.
- Drive ratio: 4.30:1
- Cross locks available as optional fitment.

SiTEC 255

Maximum Power : 191 kW @ 2,500 RPM

Maximum Torque : 745 Nm @ 1,500 RPM

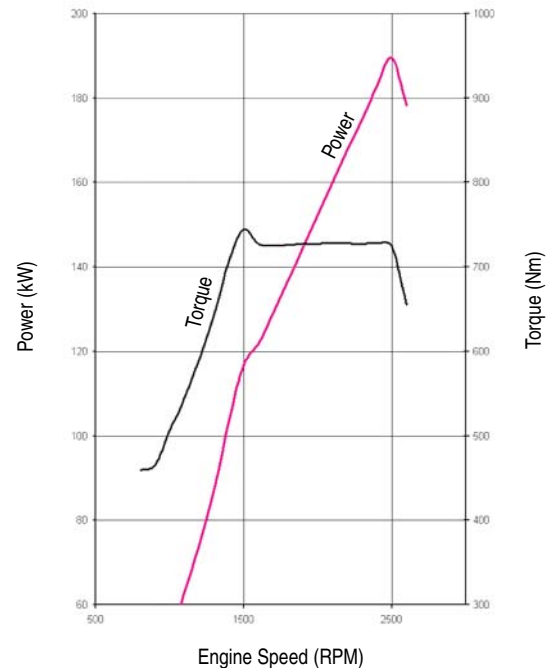

ISUZU SiTEC 255 (6HK1-TCS) ENGINE PERFORMANCE CHART

SUSPENSION

FRONT

- Single stage, alloy steel, taper leaf springs. Fully wrapped eye with greasable shackles.
- Nominal size: 1,600 x 80 mm
- Total spring capacity (at ground): 6,670 kg
- Double acting, hydraulic shock absorbers. Stabiliser bar.

REAR FVR 950

- Two stage, alloy steel, multi-leaf springs. Fully wrapped eye with greasable shackles.
- Nominal size: 1,420 x 100 mm
- Total spring capacity (at ground): 11,300 kg
- Stabiliser bar.

REAR FVD 950

- Hendrickson HAS230 airbag.
- Two rolling lobe air springs.
- Total spring capacity (at ground): 10,430 kg
- Outboard mounted, double acting shock absorbers.
- Height control valve.

BRAKES

- Meritor 'Q-Plus' Full air 'S-cam' brakes with automatic slack adjusters.
- Front drum diameter: 419 mm
- Rear drum diameter: 419 mm
- Swept area: 8,030 cm²
- Asbestos free lining material.
- Spring type parking brake acting on rear wheels.
- Air controlled exhaust brake.
- 78.5 L total air reservoir capacity.
- Air dryer.
- ABS sensor rings and sensor brackets fitted to steer and drive axles.

STEERING

- Power assisted recirculating ball steering.
- 22.4:1 gear ratio.
- 5.4 turns lock to lock.
- 45° wheel cut angle (inside wheel).

WHEELS AND TYRES

- 8.25 x 22.5 Ten stud ISO standard disc wheels.
- 295/80R22.5 152/148M Michelin XZE2 steer tyres.
Rating: 3,550 kg per tyre.
- 11R22.5 148/145L Michelin XDE2 drive tyres.
Rating: 2,900 kg per tyre (dual configuration).
- Frame mounted winch type spare wheel carrier.
Spare wheel and XZE2 tyre assembly supplied.

AXLE LOAD SUMMARY

FVR 950	FRONT	REAR
Axle Capacity (kg):	6,600	10,400
Spring Capacity (kg):	6,670	11,300
Tyre Capacity (kg):	7,100	11,600
Legal Limit (kg):	6,000	9,000
Limit (kg):	6,000	9,000

FVD 950

	FRONT	REAR
Axle Capacity (kg):	6,600	10,400
Spring Capacity (kg):	6,670	10,430
Tyre Capacity (kg):	6,300	11,600
Legal Limit (kg):	6,000	10,000
Limit (kg):	6,000	10,000

Note: Vehicle loading limit is determined by the combination of axle loading limit, GVM and GCM limit, and government regulatory requirements. Consult your Isuzu dealer to select the correct vehicle for your specific application.

CHASSIS FRAME

- Cold riveted ladder frame with parallel side rails.
- Frame material
Side rail (mm):
Rear frame width (mm):
- Frame reinforcement section.

	Medium	Long
HT540A		SAPH440
254 x 85 x 8		258 x 85 x 10
850		850

ELECTRICAL SYSTEM

- 24 Volt electrical system.
- 24 Volt, 60 Amp alternator.
- 24 Volt, 4.5 kW starter motor.
- 2 x 75D23R (520CCA) batteries connected in series.

CABIN SPECIFICATIONS AND APPOINTMENTS

CAB EXTERIOR

- All steel cab, side door impact protection beams. Outer body panels galvanised, corrosion resistant primer treated cab.
- Manual cab tilt to 45°. Access to fluid checkpoints without tilting cab. Front access panel for clutch, windscreen washer fluids and cab air filter screen. Four point silicone filled rubber cab mounting.
- Body coloured steel front bumper with step holes and integrated indicator and fog lamps.
- 90° opening internally reinforced door. Heavy duty aluminium non slip entry steps.
- Laminated windscreen. 2 speed windscreen wiper system, variable intermittent wipe mode, triple washer jets.
- Halogen headlamps. Park lamps and roof-mounted clearance lamps.
- Combination brake, turn, reverse and marker lamps, registration plate illumination lamps. Extended wiring harness. Reverse alarm.
- 'West Coast' type rear view mirrors. Large flat mirror glass with additional, independently adjustable convex 'spot' mirror on both sides.

CAB INTERIOR

- Isringhausen ISRI 6500/517 air suspension driver's seat, auto weight adjustment to 130 kg. Height, rake and backrest recline adjustment. Pneumatic lumbar support. Reclining passenger bucket seat, centre seat with folding seat back.
- 3-point, lap sash seatbelts with emergency locking belt retractors in all outboard seating positions. Centre lap seatbelt.
- 'A' pillar entry assist grips. Fluorescent dome interior lamp with On/Door/Off switch activated by either door.
- Full interior panel trim, padded roof lining, vinyl floor mats. Windscreen header storage shelf. DIN sized aperture in dash for CB.

- Tilt/Telescopic adjustable steering column, soft feel urethane steering wheel.
- 12 Volt, 100 Watt and 24 Volt, 2 pin accessory sockets located in centre console.
- Electric windows.
- Central locking with remote keyless entry.
- Centre facia pullout drinks holder. Lockable compartment on centre seat back. Cigarette lighter.
- Heater/Demister with 4-speed fan and outlets for windscreen, side windows, face and floor.
- Standard fully integrated air conditioning.
- Two speaker radio/CD player with clock. CD player compatible with standard (WAV)/MP3/WMA music file types.
- Remote seek/volume and mute switch located on dash to right of steering wheel.
- Optional 10 stack CD player.

DRIVER CONTROLS

- Key-operated engine start/stop and steering lock. Engine idle speed control.
- Left side combination stalk: Windscreen wipers, washers, exhaust brake and hazard lights.
- Right side combination stalk: Turn signals and headlamps.

INSTRUMENTATION

- Gauges: Electronically driven speedometer, odometer, tripmeter, tachometer. Gauges for coolant temperature and brake air pressure.
- Warning lamps: Warning bulb check switch. Battery charge, brake system, engine malfunction, oil pressure, stop and tail lamp failure.
- Indicator lamps: Turn signals, parking brake, high beam, exhaust brake engaged.

FVR 950 9 spd Medium / Long

FVD 950 9 spd Long

PERFORMANCE (Calculated)

	FVR 950 9 spd	FVD 950 9 spd
Max Geared speed:	114* km/h @ 2,600 rpm	114* km/h @ 2,600 rpm
Gradeability (lowest gear):	48% at 15,000 kg GVM	45% at 16,000 kg GVM
Gradeability (top gear at 100 km/h):	0.7% (2.5 x 3.4 m van body at 15,000 kg GVM)	0.6% (2.5 x 3.4 m van body at 16,000 kg GVM)
Engine speed (top gear at 100 km/h):	2,200 rpm	2,200 rpm

Performance figures quoted are representative only and based on typical dimensions, body styles and weights. Please consult your Isuzu dealer for an estimation based on your specific application. * Road speed limited to 100 km/h

MODEL RATINGS AND DIMENSIONS

MODELS	RATINGS (kg)		TARE MASS [#] (kg)			DIMENSIONS (mm)													TURN CIRCLE
	GVM*	GCM	TOTAL	FRONT	REAR	WB	OAL	FOH	ROH	EA	CE	RT	ORT	CH	CW	FFH	RFH	KERB TO KERB	
FVR 950 Medium	16,500	26,000	4,880	2,885	1,995	4,250	7,400	1,250	1,900	3,285	5,440	1,840	2,450	2,770	2,440	990	1,045	15.0 m	
FVR 950 Long	16,500	26,000	5,235	3,085	2,150	6,250	10,000	1,250	2,500	5,285	8,040	1,840	2,450	2,770	2,440	995	1,055	20.1 m	
FVD 950 Long	16,500	26,000	5,100	3,090	2,010	6,250	10,000	1,250	2,500	5,285	8,040	1,840	2,450	2,770	2,440	995	1,010	20.1 m	

*Maximum optional GVM rating. # Estimated mass of cab/chassis with oil, water and fuel tank containing 10 litres of fuel and excluding spare wheel (95 kg) and tools (30 kg).

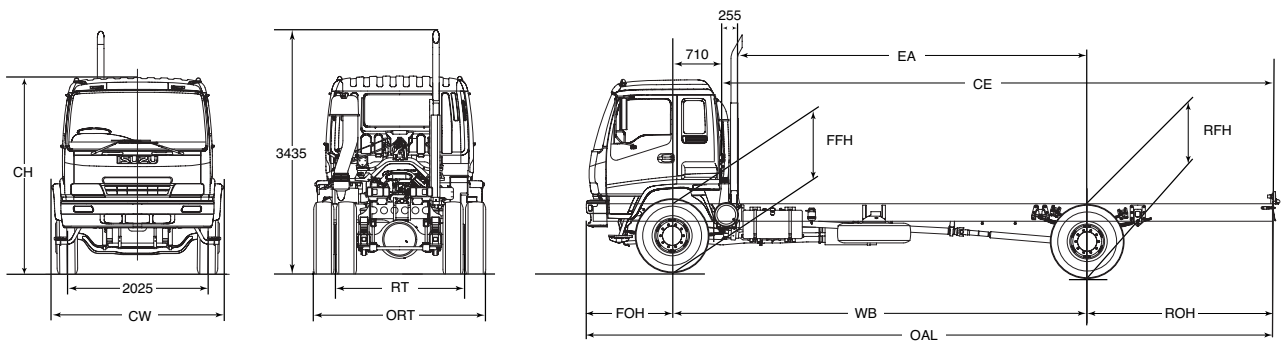

For further information regarding Cab/Chassis dimensions your Isuzu Dealer can access detailed Body Builders diagrams from the Isuzu Truck Technical Reference CD.

	Model	Medium	Long
ORDER CODES	FVR 950 9 spd	8FQ02-6G0 (MU6)	8FR02-6G0 (MU6)
	FVD 950 9 spd	N/A	8FR02-6G1 (MU6)

ISUZU NEW TRUCK WARRANTIES

STANDARD TRUCKPOWER WARRANTY*			TRUCKPOWER EXTENDED WARRANTY OPTIONS*		
New Vehicle	3 years	150,000 km	4 years 250,000 km	5 years 300,000 km	6 years 350,000 km
Drivetrain	3 years	150,000 km			
Cab Corrosion	3 years	unlimited			

* Subject to the conditions outlined in the IAL New Vehicle Warranty, the Isuzu FVR & FVD models carry a standard factory warranty which covers the owner: (i) for the entire vehicle, for the first 36 months or 150,000 km (whichever comes first). (ii) for the drivetrain, which runs concurrently, for 36 months or 150,000 km (whichever comes first). (iii) against cab corrosion, for 36 months and unlimited kilometres.

* A TruckPower Extended Warranty as illustrated is available by purchase to cover the owner against the failure of original components, but excludes some components and expendable items such as oil, filters, etc. Please consult with your Isuzu Dealer for full details obtained from a dedicated brochure available to customers.

ISUZU AUSTRALIA LIMITED A.C.N. 006 962 572. PLEASE NOTE: as the policy of IAL is one of continual product improvement, all specifications and equipment are subject to change without notice. No IAL dealer or other person is authorised or permitted to give or make any statement, assertion or undertaking in relation to the quality, performance, characteristics, descriptions or fitness for any purpose of any IAL product or in connection with the supply of any IAL product which is at variance with any written statement, assertion or undertaking on any of these subjects given or made by IAL in its published sales literature, and the company accepts no liability for any such unauthorised action. IAL has franchised dealers in many parts of Australia, for the sale of service, parts and the provision of service to the owners of IAL products. Every endeavour is made to ensure that such dealers carry adequate stocks of service parts and are equipped to provide satisfactory service, but makes no promise, other than that contained in the IAL new vehicle warranty, that such parts or service facilities will be available or available at any specific location or at any particular time. A word about this specification sheet. We have tried to make it as comprehensive and factual as possible. However, since the time of printing some of the information you will find here may have been updated. Also, some of the equipment shown or described through this specification sheet may have been changed and/or is available at extra cost. And the right is reserved to make changes at any time without notice, in prices, colours, materials, equipment and models. Your IAL dealer has details and before ordering, you should ask him/her to bring you up to date.

DECEMBER 2006. ARK 0221

ISUZU

RELIABILITY IS EVERYTHING