

# 9000

**FVR 900 MEDIUM**

**GVM: 16,000kg**  
**GCM: 24,000kg**  
**WHEELBASE: 4,200mm**

## ISUZU 6SA1 ENGINE PERFORMANCE

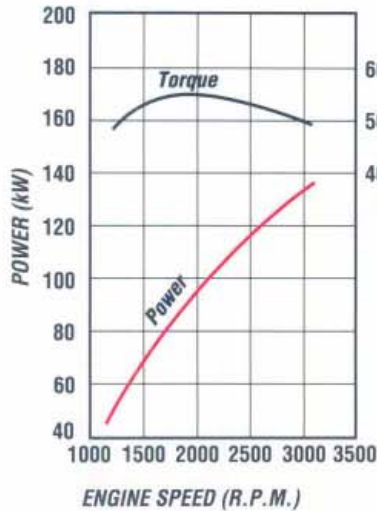

- Type: 6 cylinder, overhead camshaft diesel, four stroke, direct injection
- Bore x Stroke 115 x 135 mm
- Displacement 8413 cc
- Compression Ratio 16.5:1
- Output-Power 134 kW @ 2520 rpm (DIN Nett)
- Torque 560 Nm @ 1400 rpm (DIN Nett)

## DIMENSIONS AND WEIGHTS

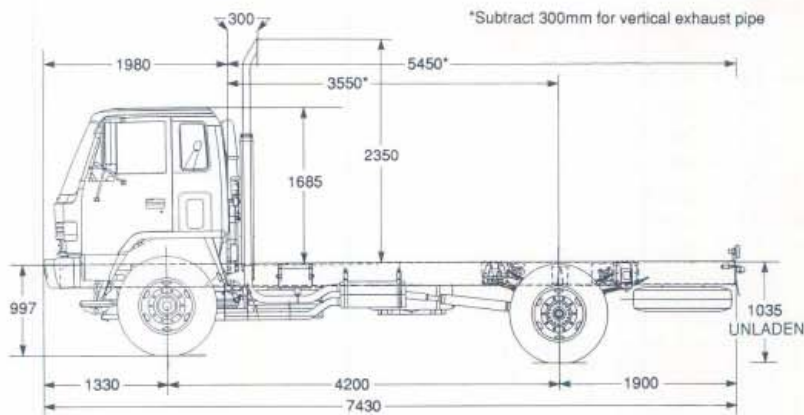

*ESTIMATED KERB MASS (kg)	
FRONT	2764
REAR	2066
TOTAL	4830
FRAME WIDTH (mm)	850
TURNING CIRCLE (m)	
Kerb to Kerb	15.5
BODY LENGTH (mm)	5486
Subject to weight distribution	

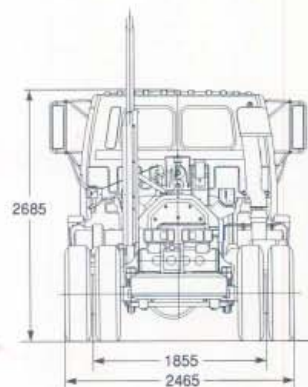

\*Chassis and cab with oil, water and fuel tank containing 10 litres of fuel.

ISUZU-GENERAL MOTORS AUSTRALIA LTD A.C.N. 006 962 572

12/50 WARRANTY. Every Isuzu Truck is covered by the I-GM new vehicle warranty which covers your vehicle for the first 12 months or 50,000 kilometres.

PLEASE NOTE: as the policy of Isuzu-General Motors Australia Motors is one of continual product improvement, all specifications and equipment are subject to change without notice. Body illustrated are not standard. No I-GM dealer or other person is authorised or permitted to give or make any statement, assertion or undertaking in relation to the quality performance characteristics descriptions or fitness for any purpose of any I-GM product or in connection with the supply of any I-GM product which is at variance with any written statement assertion or undertaking on any of these subjects given or made by Isuzu-General Motors Australia Limited in its published sales literature, and the company accepts no liability for any such unauthorised action. Isuzu-General Motors Australia Limited has franchised dealers in many parts of Australia. For the sale of service parts and the provision of service to owners of I-GM products. Every endeavour is made to ensure that such dealers carry adequate stocks of service parts, and are equipped to provide satisfactory service, but makes no promise, other than that contained in the New Vehicle Warranty given by Isuzu-General Motors Australia Limited, that such parts or service facilities will be available, or available at any specific location or any particular time.

CT3295 4/92

ISUZU



# ISUZU 900

## FVR 900 MEDIUM

**ORDERING CODE:**  
8FQ02-641

### ENGINE - ISUZU 6SA1

#### Lubrication:

- Pressure feed lubrication with full flow paper element and partial flow sub filter. Plate type oil cooler in water jacket. Oil capacity 16.0 litres including filter.

#### Cooling System:

- Six blade plastic cooling fan, size 475 mm diameter with thermatic fan clutch.
- Tube and corrugated fin pressure type radiator with bell mouth fan shroud. Size (mm) 622 h x 559 w x 71 t. Frontal area 0.348 m<sup>2</sup>.
- Coolant capacity 25 litres.

### FUEL SYSTEM

- Two stage paper element air cleaner, Donaldson 11" with vertical air intake stack and rain head.
- In line plunger, Bosch 'AD' type fuel injection pump with mechanical all speed governor.
- In line paper filter, see through water separator with drain cock.
- Fuel tank capacity 200 litres.
- Horizontal exhaust muffler with vertical exhaust stack.

### CLUTCH

- Hydraulic control dry single plate with coil type cushioning springs. 350 mm (14") diameter. Lining area 1164 cm<sup>2</sup> (each side).
- Air Servo assistance.
- Asbestos free lining material.

### TRANSMISSION ISUZU MLD7R

- Seven speed overdrive, constant mesh with synchromesh on gears 2-7 and power assisted shift control, oil capacity 8.3 litres.
- **Gear Ratios:1**

1st	8.181
2nd	5.167
3rd	3.333
4th	2.105
5th	1.347
6th	1.000
7th	0.863
Reverse	8.307
- Maximum geared speed 99 km/h.
- Two piece propeller shaft, 90 mm diameter Length:
 

1st section	696 mm
2nd section	1267 mm

### REAR AXLE - CAPACITY 10,500kg

- Banjo type, fully floating, single reduction. Ratio 5.571:1
- Hypoid type ring gear, 431 mm diameter Oil capacity 8 litres

### REAR SUSPENSION

- Semi-elliptical, alloy steel tapered multi leaf springs. Fully wrapped eye with greasable shackles.

- Size - length x width x thickness, No. leaves:
 

Main:	1420 x 100 x 12 mm - 8 leaves
Auxiliary:	980 x 100 x 10 mm - 2 leaves
	980 x 100 x 11 mm - 4 leaves
- Stabiliser bar.

### FRONT AXLE CAPACITY - 6,300kg

- Reverse Elliot I-beam type. King pin diameter 50 mm with cylindrical roller thrust bearing. Oil filled front hubs with demountable brake drums.

### FRONT SUSPENSION

- Semi-elliptical, alloy steel taper leaf springs. Fully wrapped eye with greasable shackles.
- Size - length x width x thickness, No. leaves:
 

	1470 x 80 x 20 mm - 1 leaf
	1470 x 80 x 22 mm - 2 leaves
- Stabiliser bar.
- Hydraulic, double acting, telescopic shock absorbers.

### STEERING

- Fully integral power assisted recirculating ball type. Gear ratio 22.4:1. Turns lock to lock 5.4.
- Gear driven vane type oil pump, oil capacity 3.5 litres.

### BRAKES

- Full air 'S', cam, dual circuit front and rear leading and trailing. Drum diameter 419 mm. Total swept area 8690.6 cm<sup>2</sup>.
- Air tank capacity 50 litres with air dryer.
- Compressor bore x stroke 85 x 60 mm driven at half engine speed.
- Spring parking brake acting on rear wheels.
- Butterfly, air controlled exhaust brake system. Activation switch on wiper/washer control stalk.

### CHASSIS FRAME

- Parallel rail, ladder type, channel section, cold rivetted.
- Side member dimensions 254 x 85 x 8 mm
- Frame reinforcement angle section 224 x 77 x 4.5 at back of cab
- Material SAPH45, mild steel.

### WHEELS AND TYRES

- 8.25T x 22.5 - 10 stud disc wheels, 22 mm bolt size.
- 11R 22.5 - 16 ply radial tyres.
- Number of tyres, 7 including spare.
- Winch type spare wheel carrier.

### ELECTRICAL SYSTEM

- Batteries - 2 x 12 volt - 55 amp/h, negative earth.
- Alternator - 24 volt - 40 amp.
- Starter motor - 24 volt - 5.5 kW output.
- Rear stop and tail lamps and licence plate lamp with long leads for variable body mounting. Turn signal side indicator lamps for body mounting.

### CAB EXTERIOR

- All steel cab, manual tilt to 45°, electro deposition primer, torsion bar counter balanced with silicon sealed hydraulic mountings.
- Heavy duty bumper bar with 4 rectangular halogen headlamps inset.
- Combination turn signal and park lamps.
- Laminated windshield, 2 speed wiper/washer with intermittent mode.
- Front and rear quarter vent windows.
- West Coast type rear view mirrors with clearance lamps.
- Corrosion resistant, non-slip cab entry steps.
- Access to fluid checks without tilting cab.
- Tool kit with 10,000 kg capacity jack.

### CAB INTERIOR

- Fully trimmed cab interior with cloth seat facings, formed roof lining and overhead parcel shelf with driver and passenger sun visors.
- ISRI 5000 drivers seat with mechanical suspension and lumbar support, adjustment for seat back recline, seat slide and height control.
- Outboard passenger seat, folding centre seat back with lockable compartment and snack tray.
- Outboard lap/sash seat belts with emergency locking retractors, inboard lap seat belt.
- Tilt telescopic adjustable steering column, soft feel urethane steering wheel.
- Easy entry grab handles on 'A' and 'B' pillars.
- Heater demister with 4 speed fan, 4 outlets to screen, 5 fascia outlets, 5 foot outlets.
- AM/FM radio with digital clock, dash mounted.
- Park brake activation lever beside drivers seat.

### INSTRUMENTATION

- Speedometer, odometer and tachometer.
- Gauges for coolant temperature, fuel level and brake air pressure.
- Dash illumination control.

### INDICATOR LAMPS

- Turn signals, parking brake on, high beam on, exhaust brake engaged.

### WARNING LAMPS

- With warning bulb check switch.
- Battery charge, oil filter clogged, oil pressure, low air pressure, air cleaner clogged, stop and tail lamp failure.

### SWITCHES

- Left side combination switch for exhaust brake, wipers and washer.
- Right side combination switch for headlamps, turn signals, and headlamp dip.
- Hazard lamp switch.
- Key operation for engine stop and start, external engine crank switch for service when cab is tilted.
- Three way switch for interior lamp activated by driver and passenger doors.
- 24 volt 2 pin accessory plug on centre fascia.