

ISUZU

SPECIFICATIONS

NEW
NEW GENERATION ISUZU
GEN

FTR 900

FTR 900 Crew



FTR 900 Crew



FTR 900

AUSTRALIA'S TOP SELLING TRUCK BRAND SINCE 1989. Truck tracker 2007.

AT A GLANCE

GVM	15,000 kg
GCM	24,000 kg**
Power	191 kW @ 2,400 rpm
Torque	761 Nm @ 1,450 - 2,400 rpm

UPGRADE OPTIONS

Premium Pack:

- Automated Manual Transmission (AMT)
- Instrument panel multi-information display
- Cruise control
- Auto control for airconditioning (except crew)

ADVANCED TECHNOLOGY

- Driver airbag with seatbelt pretensioner
- ADR 42 compliant sleeper with mattress
- Anti-lock Braking System (ABS)
- Hill Start Aid (HSA)
- Electric mirrors
- Electro-hydraulic cab tilt
- Coil spring cab suspension (except crew)
- Front and rear stabiliser bars
- ISRI 6860 seat with integrated seatbelt

** Refer to back page weights table for details.

RELIABILITY IS EVERYTHING **ISUZU**

Driveline & Chassis Specifications

ENGINE: SITEC SERIES II 255 (ISUZU 6HK1-TCC)

- Type:** 6 cylinder 24 valve SOHC
Displacement: 7,790 cc
Compression Ratio: 17.5:1
Bore x Stroke: 115 mm x 125 mm
Max power (DIN-NET): 191 kW (256 HP) @ 2,400 RPM
(JIS Gross): 198 kW (265 HP) @ 2,400 RPM
Max torque (DIN-NET): 761 Nm (561 lb.ft) @ 1,450 - 2,400 RPM
(JIS Gross): 788 Nm (581 lb.ft) @ 1,450 - 2,400 RPM
Induction system: Electronically controlled variable nozzle turbocharger with air-to-air intercooler.
Fuel injection: Direct injection high pressure common rail system.
Emission control system: Two-stage electronically controlled cooled EGR with exhaust Diesel Particulate Diffuser (DPD). ADR 80/02 (Euro IV) compliant.

CLUTCH

- Standard and MW model:**
- Air assisted hydraulic control. Single plate 381 mm diameter.
 - Total lining area: 1,363 cm²
- Premium Pack:**
- Fully automated hydraulically controlled wet clutch and fluid coupling with lock up.

TRANSMISSION

ISUZU MZX-6P (except MW model)

- Synchromesh on gears 2-6. Triple cone synchromesh on 2nd and 3rd gears. Integral oil pump provides full pressure lubrication.
 - Gear ratios (: 1)
- | 1st | 2nd | 3rd | 4th | 5th | 6th | Rev |
|-------|-------|-------|-------|-------|-------|-------|
| 6.615 | 4.095 | 2.358 | 1.531 | 1.000 | 0.722 | 6.615 |

Standard model:

- 6 speed manual with air assisted shift.

Premium Pack:

- 6 speed Automated Manual Transmission (AMT) with both fully automatic and clutchless manual operation modes.

ISUZU MLD-6W (MW model)

- 6 speed manual with air assisted shift.
- Synchromesh on gears 2-6.
- PTO provision on LHS of transmission case. PTO drive from counter gear.
- Gear ratios (: 1)

1st	2nd	3rd	4th	5th	6th	Rev
6.120	4.244	2.580	1.540	1.000	0.763	6.525

AXLES

Front: Isuzu F063

- Reverse Elliot I-Beam. 6,300 kg capacity.

Rear: Isuzu R092

- Full floating Banjo type. 9,200 kg capacity.
- Drive ratio: 5.571:1 (FTR 900, FTR 900 medium MW), 5.125:1 (FTR 900 long MW, FTR 900 crew MW)

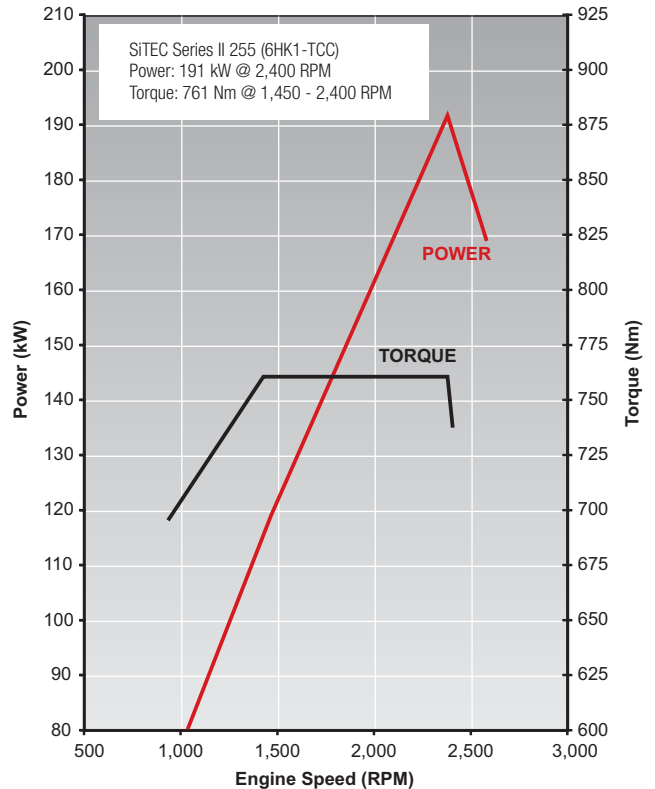

SUSPENSION

Front:

- Single stage alloy steel taper leaf springs.
- Double acting hydraulic shock absorbers. Stabiliser bar.

Rear:

- Multi leaf main spring, multi leaf helper spring. Stabiliser bar.

BRAKES

- Dual circuit full air taper roller front and rear drum brakes.
- ABS.
- Hill Start Aid (HSA).
- Front drum size: 410 x 160 mm
- Rear drum size: 410 x 180 mm
- Spring park brake.
- Air controlled exhaust brake.
- Air dryer.

STEERING

- Power assisted recirculating ball steering.
- Gear ratio: 22.4:1
- Turns lock to lock: 4.8
- Maximum angle: 49° (inside wheel) / 37° (outside wheel)

WHEELS AND TYRES

- 22.5 x 8.25 ten stud steel wheels.
- 275/70R22.5 148/145M Michelin XZE2 Tubeless.
- Maximum tyre rating:
Steer axle: 6,300 kg
Drive axle: 11,600 kg
- Spare wheel and tyre assembly with winch type carrier.

CHASSIS FRAME

- Cold rivetted ladder frame with parallel side rails. HT540A high tensile weldable steel sidemembers.
- Frame dimensions:
Side rail (mm): 254 x 85 x 8.0
Rear frame width (mm): 850

FUEL TANK

- Frame mounted 200L steel fuel tank.
- Lockable fuel cap.

ELECTRICAL SYSTEM

- 24 volt electrical system.
- **Single cab:** 60 amp alternator. **Crew cab:** 90 amp alternator.
- 24 Volt, 4.5 kW starter motor.
- 2 x 80D26L (630 CCA) batteries connected in series.

Cabin Specifications and Appointments

CAB EXTERIOR

- All steel construction with electro-hydraulic cab tilt. High tensile steel used for cab underframe.
- **Single cab:** Full floating cab with coil spring suspension. **Crew cab:** Rubber cab mounts.
- Heavy duty non slip entry steps.
- 90° opening internally reinforced front doors.
- Water spray suppression guards and front mudflaps.
- Laminated windscreen with shade band.
- Two speed windscreen wipers with intermittent wipe mode.
- Halogen multi-reflector headlamps incorporating turn signals and front foglamps. Additional door mounted side indicator lamps.
- Combination brake, turn, reverse and marker lamps, registration plate illumination lamps. Extended wiring harness. Reverse alarm.
- Roof-mounted clearance lamps.
- Heated and powered exterior main mirrors with flat glass and additional powered convex "spot" mirrors.
- Body coloured grille.
- Body coloured steel air dam bumper.

CAB INTERIOR

- Isri 6860 air suspension driver's seat with pneumatic lumbar support, height, rake and automatic weight adjustment.
- Front passenger adjustable bucket seat and front centre seat with folding seat back.
- **Crew cab:** Rear bench seat with 4 seat capacity.
- 3-point lap sash seatbelts in all outboard seating positions. Driver seatbelt with pre-tensioner integrated with driver seat. Centre seat lap belts.
- **Single cab:** ADR 42 compliant sleeper with mattress.
- Driver airbag.
- **Premium Pack:** Driver's footrest.
- Door and roof pillar entry assist grips. **Crew cab:** Full width rear grab rail with ashtray.
- Full interior trim, padded roof lining and vinyl floor covering. Driver and passenger windscreen header storage shelf.
- Tilt/Telescopic adjustable steering column, soft feel urethane steering wheel.
- Electric windows.
- Central locking with remote keyless entry and immobiliser.
- Twin cup holders. 24V cigarette lighter. Dashboard hook.
- Front door mounted storage pockets and driver's side ashtray.

- Centre console box with storage tray. Fold down storage tray behind centre seat backrest.
- Front passenger glovebox.
- Fully integrated air conditioning and heater/demister with 4-speed fan and outlets for windscreen, side windows, face and floor. **Except single cab Premium Pack:** Manual control. **Single cab Premium Pack:** Auto control.
- Fluorescent type interior lamp with On/Door/Off switch.
- 2 DIN, two speaker radio/CD multimedia unit.
- DIN sized compartment for storage or for CB radio installation.

DRIVER CONTROLS

- Key-operated engine start/stop and steering lock. Engine idle speed control.
- HSA slow/fast engagement control and on/off switch.
- DPD regeneration.
- **Premium Pack:** AMT slow/fast gear engagement control, 1st gear start and normal/economy gear selection modes.
- **Left side combination stalk:** Windscreen wipers, washers and exhaust brake.
- **Right side combination stalk:** Turn signals and headlamps. **Premium Pack:** Cruise control.

INSTRUMENTATION

- Electronically driven speedometer and tachometer. Digital odometer with integrated dual tripmeter. Engine coolant temperature, fuel level and air pressure gauges.
- **Warning lamps:** Check engine, oil pressure, ABS, SRS airbag, alternator charge, service brakes, park brake, seat belt unfastened, low air pressure, low fuel level, cab lock. **Premium Pack:** Check AMT.
- **Indicator lamps:** HSA, warm up system, high beam, DPD status, exhaust brake, turn signals. **Premium Pack:** Cruise control, econo-mode, 1st gear start.
- **Premium Pack:** Gear selection display.
- **Premium Pack:** Multi-information display. Shows service interval, instantaneous and average fuel consumption, DPD bar chart, hourmeter, voltmeter, time/day/date and includes 40-120 km/h adjustable vehicle speed warning.

OPTIONS AND GENUINE ACCESSORIES

Include the following (extra cost, check with dealer for availability):

- Module for Bluetooth/iPod input/SD card reader.
- Module for Bluetooth/iPod input/SD card reader/satellite navigation (includes NAVTEQ mapping).
- Up to two reversing cameras.
- Cloth seat covers.

Weights (kg)

Models	Ratings*		Loading Limit* (at ground)		Cab Chassis Mass#		
	GVM	GCM	Front	Rear	Front	Rear	Total
FTR 900 Medium	15,000	24,000**	6,300	9,200	3,040	1,730	4,770
FTR 900 Medium MW	15,000	24,000**	6,300	9,200	3,085	1,735	4,820
FTR 900 Long	15,000	24,000**	6,300	9,200	3,230	1,800	5,030
FTR 900 Long MW	15,000	24,000**	6,300	9,200	3,270	1,820	5,090
FTR 900 Long Premium	15,000	24,000**	6,300	9,200	3,240	1,800	5,040
FTR 900 Crew	15,000	24,000**	6,300	9,200	3,290	1,900	5,190
FTR 900 Crew MW	15,000	24,000**	6,300	9,200	3,330	1,905	5,235
FTR 900 Crew Premium	15,000	24,000**	6,300	9,200	3,300	1,900	5,200

* Vehicle ratings and front/rear weight limits are subject to government regulatory requirements and weight distribution analysis. Consult your Isuzu dealer to select the correct vehicle for your specific application.
 ** For tow couplings with a rating over 4,500 kg brake performance matching with trailer is required to ensure compatibility under ADR 35/01. # Cab chassis only as supplied and including 10 litres of fuel.

Dimensions (mm)

Models	WB	OAL	FOH	ROH	EA	CE	RT	ORT	CH	FFA (unladen)	RFA (unladen)	RFH (unladen)	Turn Circle (m)
													KERB TO KERB
FTR 900 Medium	4,250	7,405	1,440	1,715	3,550	5,340	1,820	2,430	2,725	945	1,025	1,050	14.1
FTR 900 Long	6,500	10,740	1,440	2,800	5,800	8,675	1,820	2,430	2,725	935	1,010	1,040	21.6
FTR 900 Crew	6,050	10,005	1,440	2,515	4,625	7,248	1,820	2,430	2,725	935	1,015	1,055	20.1

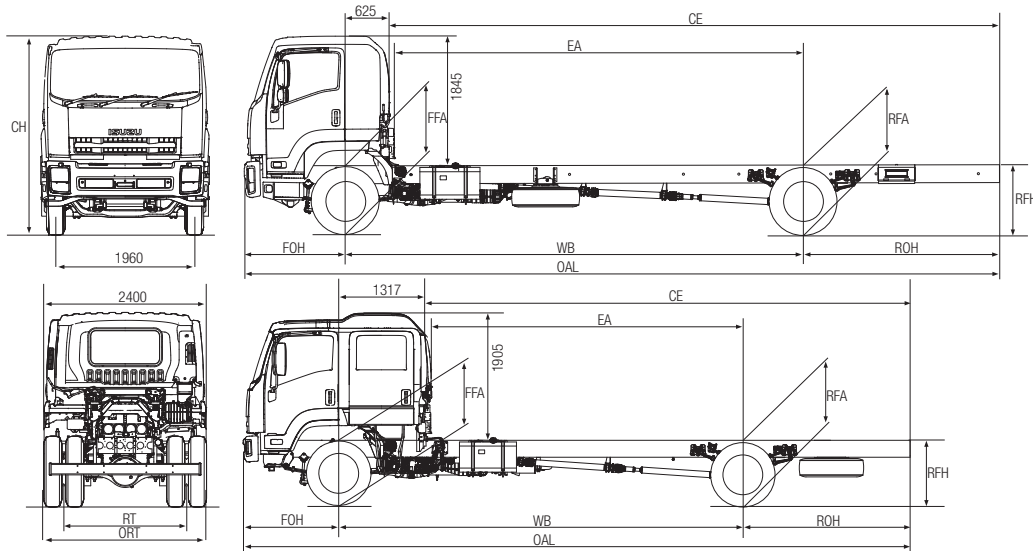

Performance (calculated - typical paved road)

	Geared Speed* (top gear at peak power engine RPM)	Low Speed Gradeability (lowest forward gear assuming no wheel slip)	Engine Speed (top gear at 100 km/h)
FTR 900	At 15,000 kg GVM 106 km/h @ 2,400 RPM	36%	2,275 RPM
FTR 900 Medium MW	At 15,000 kg GVM 100 km/h @ 2,400 RPM	33%	2,400 RPM
FTR 900 Long MW / Crew MW	At 15,000 kg GVM 109 km/h @ 2,400 RPM	31%	2,210 RPM

* Maximum speed achievable depends on vehicle frontal area as well as other factors. Consult your Isuzu dealer for more detailed information. Vehicle is speed limited to 100km/h.

Isuzu Warranties

STANDARD ¹		
New Vehicle	3 years 150,000 km 2,500 hrs	
Cab Perforation Corrosion	3 years Unlimited km	
EXTENDED ²		
4 years 250,000 km	5 years 300,000 km	6 years 350,000 km

Order Codes

Model	Code	Model	Code
FTR 900 Medium	FH-FTRJH-B01	FTR 900 Long Premium	FH-FTRKH-Z01
FTR 900 Medium MW	FH-FTRJH-T01	FTR 900 Crew	FH-FTRLH-C01
FTR 900 Long	FH-FTRJH-D01	FTR 900 Crew MW	FH-FTRLH-W01
FTR 900 Long MW	FH-FTRJH-X01	FTR 900 Crew Premium	FH-FTRMH-C01

¹ Subject to the conditions outlined in the IAL New Vehicle Warranty, the Isuzu FTR models carry a standard factory warranty which covers the owner: (i) for the entire vehicle, for the first 36 months or 150,000 km or 2,500 hrs (whichever comes first). (ii) against cab perforation corrosion, for 36 months and unlimited kilometres. ² Extended Warranty as illustrated is available by purchase to cover the owner against the failure of original components, but may exclude some components and expendable items such as oil, filters, etc. Please consult with your Isuzu Dealer for full details obtained from a dedicated brochure available to customers.

ISUZU AUSTRALIA LIMITED ABN 97 006 962 572 ("IAL"). The information in this brochure was correct at time of printing, but all measurements, specifications and equipment are subject to change without notice. Some equipment may have been changed and/or is available at extra cost. IAL may make changes at any time without notice, in prices, colours, materials, equipment and models. IAL makes all reasonable attempts to ensure the availability of all vehicles and equipment. The information in this brochure is general in nature. Your Isuzu dealer can confirm all measurements, specifications and vehicle / equipment availability upon request.

July 2008. ARK0333