

ISUZU FRR 550

MEDIUM/PTO/LONG

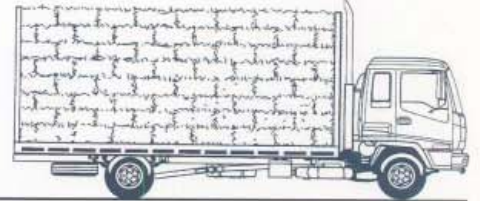
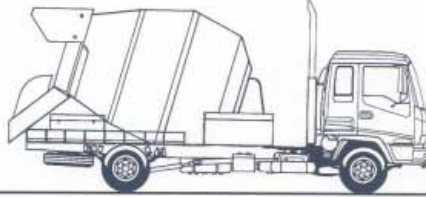

ENGINE ISUZU 6HH1-N

- Type:** 6 cylinder, overhead camshaft, 4 stroke, direct injection, diesel.
- Bore x Stroke:** 115 mm x 132 mm.
- Displacement:** 8226 cc.
- Compression Ratio:** 18.5 : 1.
- Output - Power:** 129 kW @ 2800 RPM. (ISO 1585)
- Torque:** 490 Nm @ 1700 RPM. (ISO 1585)

CLUTCH

- Hydraulic control dry single plate. 325 mm (13") diameter.
- Asbestos free lining material. Total lining area (both sides) 966 cm².

TRANSMISSION ISUZU MBJ6T

- 6 speed overdrive, constant mesh with synchromesh on gears 2-6. Oil capacity 5.3 litres.
- Gear ratios (: 1)

1st	2nd	3rd	4th	5th	6th	Rev
6.378	3.627	2.307	1.452	1.000	0.787	6.595
- Maximum geared speed 116 km/h.
- 2 piece propeller shaft, 90 mm diameter.

REAR AXLE ISUZU R077 CAPACITY 7700 KG

- Banjo type, fully floating, single reduction. Ratio 5.125 : 1.
- Hypoid type ring gear 343 mm diameter. Oil capacity 5.5 litres.

BRAKES

- Air over hydraulic, dual circuit, front two leading, rear dual two leading. Drum diameter front and rear 320 mm. Total swept area 5127 cm².
- Air dryer.
- Asbestos free lining material.
- Spring park brake acting on rear wheels.

FLYWHEEL POWER TAKE OFF*

- Drive ratio: 0.7 : 1. *FRR550 PTO model only.
- Maximum Output Torque: 353 Nm.
- Output flange rotates in same direction as engine.

MODEL	WHEELBASE	GVM	GCM	ORDERING CODE
FRR 550 MEDIUM	4250mm	10000kg	16000kg	8FE02-261
FRR 550 PTO	4250mm	10000kg	16000kg	8FE02-263
FRR 550 LONG	4850mm	10000kg	16000kg	8FF02-261

KERB MASS (kg)*

	Front	Rear	Total
FRR 550 MEDIUM	2,090	1,020	3,110
FRR 550 PTO	2,130	1,030	3,160
FRR 550 LONG	2,130	1,040	3,170

*Estimated mass of chassis cab with oil, water and fuel tank containing 10 litres of fuel. Excluding spare wheel and tools.

DIMENSIONS (mm) *

	FRR 550 MED.	FRR 550 PTO	FRR 550 LONG
Wheelbase (WB)	4,250	4,250	4,850
Overall Length (OAL)	7,220	7,220	8,170
Rear Overhang (ROH)	1,785	1,785	2,135
Cab To Axle (CA)	3,455	3,455	4,055
Cab To End Of Frame (CE)	5,240	5,240	6,190
Front Frame Height, Unladen (FFH)	790	790	790
Front Frame Height, Laden (FFH)	761	761	761
Rear Frame Height, Unladen (RFH)	865	865	900
Rear Frame Height, Laden (RFH)	799	799	835
Turning Circle (Kerb To Kerb)	13.4m	13.4m	14.9m
Nominal Max. Body Length [†]	5,600	5,600	6,560

*Except Turning Circle: metres. *Subject to weight distribution

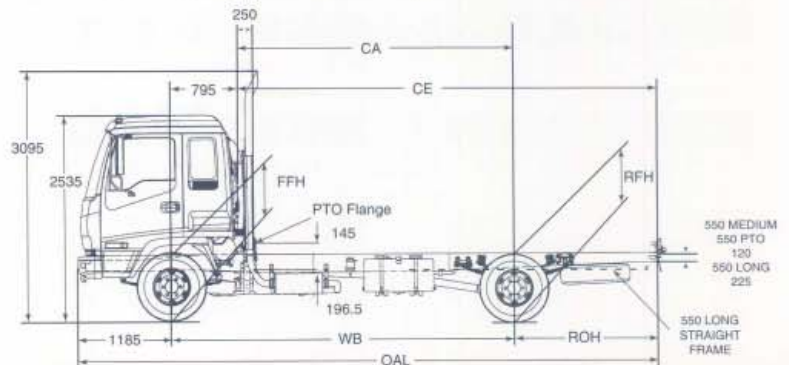
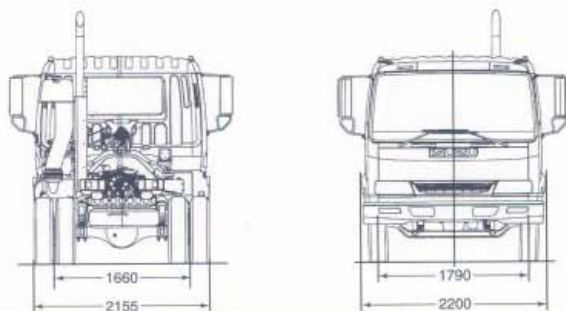

IN 21 GENERAL MOTORS AUSTRALIA LTD A.C.N. 069 062 572 21/100/000 BARRANTY. Subject to the conditions of the GCM New Vehicle Warranty, every Isuzu truck carries a warranty which covers some vehicle for the first 24 months or 100,000 kms whichever comes first, a 36 months or 150,000 kms (whichever comes first) power train warranty and a 100,000 kms or 24 months whichever comes first 24 months warranty on the chassis and all mechanical components. GCM, as the maker of ICM, is in a state of continual product improvement. All specifications and equipment are subject to change without notice. All loads described are in a standard equipment. No ICM dealer or other person is authorised to provide any statements, opinions or undertakings in relation to the quality, performance, (that includes) descriptions or fitness for any purpose of any ICM product or in connection with the supply of any ICM product which is in a state of continual improvement. Attention on such matters should be made by the purchaser of ICM or its authorised sales literature, and the purchaser accepts no liability for any such statements, opinions, ICM has authorised dealers to issue parts of, manuals, for the sale of service, parts and the provision of ICM to its customers at ICM products. There are no means made to ensure that such dealers carry adequate stocks of service parts and are equipped to provide satisfactory service, but makes no promise, other than that contained in the ICM New Vehicle Warranty, that such parts or service facilities will be available or available at any specific location or at any particular time. A word about this specific warranty. You have used the word "warranty" and "warranty" is a legal term. However, since the time of printing some of the instructions you will find here may have been replaced. Also some of the equipment shown or described may not be the same as that which you have seen. It may have been changed and/or replaced at any time, but the right is reserved to make changes at any time without notice. In general, unless otherwise stated, the ICM dealer has details and before ordering, you should call him for a more complete list.

ISUZU
RELIABILITY IS EVERYTHING

AIR CLEANER

- Donaldson 11" two stage with vertical air intake stack and rain head.

CHASSIS FRAME

- Parallel rail, ladder type channel section, cold riveted.
- Straight frame for easy body mounting. Frame width 840 mm.
- Side member dimensions 225 mm x 70 mm x 6 mm.
- Frame reinforcement angle section 203 mm x 64 mm x 4.5 mm at back of cab.
- Material HT540A high tensile, weldable steel.

COOLING SYSTEM

- 6 blade plastic cooling fan 500 mm diameter with thermatic fan clutch.
- Corrugated fin radiator with fan shroud. Frontal area 3820 cm². Coolant capacity 23.3 litres.

ELECTRICAL SYSTEM

- Batteries - 2 x 12 volt / 65 amp/h, negative earth.
- Alternator - 24 volt / 40 amp.
- Starter motor - 24 volt / 4.5 kW.
- Rear stop and tail lamps and licence plate lamp with long leads for variable body mounting.

EXHAUST SYSTEM

- Horizontal exhaust muffler with vertical exhaust stack.
- Exhaust brake, air controlled.

FRONT AXLE ISUZU F036 CAPACITY 3600 KG

- Reverse Elliot I-beam type. King pin diameter 35 mm with cylindrical roller thrust bearing.

FRONT SUSPENSION

- Semi-elliptical, alloy steel tapered multi-leaf springs. Fully wrapped eye with greaseable shackles.
- **Length x Width x Thickness x No. leaves**
1200 mm x 70 mm x 10 mm x 8
- Hydraulic, double acting, telescopic shock absorbers.

FUEL SYSTEM

- In line plunger, Bosch 'AD' type fuel injection pump with mechanical all speed governor. In line filter, see through water separator with drain cock. Single fuel tank, capacity 180 litres.

LUBRICATION SYSTEM

- Pressure feed lubrication with combination full flow and partial flow by-pass filter. Plate type oil cooler in water jacket. Oil capacity 13.5 litres including filter.

REAR SUSPENSION

- Semi-elliptical, alloy steel tapered multi-leaf springs. Fully wrapped eye with greaseable shackles.
- **Length x Width x Thickness x No. leaves**
Main: 1300 mm x 70 mm x 11 mm x 8
Aux: 850 mm x 70 mm x 10 mm x 3
850 mm x 70 mm x 11 mm x 4

STEERING

- Fully integral, power assisted, recirculating ball type.
- Gear ratio 16.1 ~ 18.8 : 1. Turns lock to lock 4.1.
- Gear driven vane type oil pump. Oil capacity 1.5 litres.

TOOLS

- Lockable tool box with 7000 kg capacity jack and wheel changing tools, tool kit.

WHEELS AND TYRES

- 6.00 x 17.5, 6 stud disc wheels, 225/90R17.5-14 ply tubeless tyres front and rear.
- Number of wheels and tyres 7, including spare. Winch type spare wheel carrier.

CAB EXTERIOR

- All steel cab with welded strengthening ribs and side door impact beams. Torsion bar assisted manual tilt to 45°.
- 4 silicon filled rubber cab isolators.
- Cation electrodeposition primer.
- Bumper bar with step holes and footplate.
- Halogen headlamps, hinged for easy bulb replacement. Park lamps and cab clearance lamps.
- Turn signal lamps in front bumper and doors.
- 2 speed wiper/washer with variable intermittent mode. Triple washer jets mounted on wiper arms.
- Tinted, laminated windshield; tinted, toughened side and rear glass.
- West Coast type rear view mirrors. Convex mirror surface on passenger side.
- Alloy non-slip cab entry steps.
- Lift up front access panel for clutch and windscreen washer fluids, cab air filter screen. Engine and brake fluid check points at rear of cab.

CAB INTERIOR

- Fully trimmed cab interior with cloth seat facings, formed roof lining. Overhead storage lockers. Driver and passenger sun visors.
- Pull out drinks holder in centre fascia, cigarette lighter with ash trays in doors.
- Driver's seat with mechanical suspension and 3 way lumbar support. Adjustment for seat back recline, seat slide and weight control.
- Outboard reclining passenger seat with under-seat storage drawer. Folding centre seat back with lockable compartment and tray.
- Outboard lap/sash seat belts with emergency locking retractors, centre lap seat belt.
- Tilt/telescopic adjustable steering column, soft feel urethane steering wheel.
- Easy entry grab handles on 'A' pillars.
- Heater demister with 4 speed fan, 4 outlet vents to screen, 5 fascia outlets, 5 foot outlets, demister ducts to door glass.
- AM/FM radio cassette with digital clock, dash mounted.
- DIN standard aperture in dash for CB radio.
- Park brake activation lever at left side of driver's seat.
- Rear vision mirror.
- Passenger side assist grip.
- Driver's left foot rest.
- Cab exhaust vents rear/upper cab.
- Business card clip. Coat hook at rear of cab.
- Elastic mesh pocket on driver's door.

INSTRUMENTATION

- Speedometer, odometer, trip meter and tachometer.
- Gauges for coolant temperature, fuel level and brake air pressure.

INDICATOR LAMPS

- Turn signals, parking brake on, high beam on, exhaust brake engaged.
- Reversing lamp and beeper.

WARNING LAMPS

- With warning bulb check switch.
- Battery charge, oil pressure, low air pressure, brake system, stop and tail light failure.

CONTROLS

- Left side combination stalk switch for exhaust brake, windscreen wipers and washer, hazard lamps.
- Right side combination stalk switch for headlamps, high beam and turn signals.
- Engine idle speed adjust control.
- Key operation for engine start and stop, external engine crank switch for service when cab is tilted.
- 3 way switch for interior lamp activated by driver and passenger doors.
- 24 volt-2 pin accessory plug in centre console.

FRR 550

MEDIUM/PTO/LONG

ISUZU

RELIABILITY IS EVERYTHING