

ISUZU

SPECIFICATIONS

FVD 165-300 4X2 DUAL CONTROL

Now with
Sat Nav fitted
as standard*



Image for illustrative purposes only.

* Satellite Navigation functions and maps provided at no extra cost, with up to four quarterly updates provided by user free download for the first three years of ownership, after which updates can be purchased at additional cost.

AUSTRALIA'S TOP SELLING TRUCK BRAND SINCE 1989.

AT A GLANCE*

GVM	16,500 kg
GCM	32,000 kg
Power	221 kW @ 2,400 rpm
Torque	981 Nm @ 1,450 rpm

* Refer to back page for detailed weight rating information

ADVANCED TECHNOLOGY

Emissions: Euro V / ADR 80/03
Meets EEV emissions standard
Driver and passenger airbag with seatbelt pretensioner
ADR 42 compliant sleeper with mattress
Anti-lock Braking System (ABS)
Electric mirrors
Electro-hydraulic cab tilt

Coil spring cab suspension
Front stabiliser bar
Cruise control
LHS and RHS ISRI 6860 seats with integrated seatbelt
Cornering lamps
High visibility entry steps and hand grips
Digital body control interface unit



ISUZU TRUCKS

DRIVELINE AND CHASSIS SPECIFICATIONS

ENGINE: ISUZU 6HK1-TCS

Type: 6 cylinder 24 valve SOHC
Displacement: 7,790 cc
Compression Ratio: 17.5:1
Bore x Stroke: 115 x 125 mm
Max power (DIN-NET): 221 kW (296 HP) @ 2,400 RPM
(JIS Gross): 228 kW (306 HP) @ 2,400 RPM
Max torque (DIN-NET): 981 Nm (724 lb.ft) @ 1,450 RPM
(JIS Gross): 1,014 Nm (748 lb.ft) @ 1,450 RPM
Induction system: Electronically controlled variable nozzle turbocharger with air-to-air intercooler.
Fuel injection: Direct injection high pressure common rail system.
Emission control system: Cooled EGR with exhaust Diesel Particulate Diffuser (DPD). ADR 80/03 (Euro V) compliant. EEV compliant.

TRANSMISSION

ALLISON 3000 SERIES

- 6 speed automatic. 5th generation electronic controls with adaptive shift.
- Allison long life TranSynd synthetic fluid.
- Gear ratios (:1)

1st	2nd	3rd	4th	5th	6th	Rev
3.49	1.86	1.41	1.00	0.75	0.65	5.03
- LHS mounted Isuzu/Hydreco PA4823JBL11G33IS Hot Shift PTO
 - Torque output rating: 730Nm standard duty (PTO only) / 615Nm standard duty (considering Allison limits)
 - 107.17% ratio
 - Rotation direction same as engine
 - SAE 1410 output flange

AXLES

Front: MERITOR

- FG941 reverse Elliot I-beam. 6,600 kg capacity.

Rear: MERITOR

- RS-23-161G. 10,400 kg capacity.
- Drive ratio: 6.428:1

SUSPENSION

Front:

- Single stage alloy steel taper-leaf springs.
- Double acting hydraulic shock absorbers. Stabiliser bar.

Rear:

- Hendrickson HAS230 airbag. 10,400 kg capacity at ground.
- Outboard mounted double acting shock absorbers.

BRAKES

- Meritor 'Q-Plus' dual circuit full air 'S-cam' front and rear drum brakes with auto slack adjusters.
- Dual air control valves for LHS and RHS driving positions
- ABS
- Front drum size: 419 x 127 mm
- Rear drum size: 419 x 178 mm
- Spring park brake.
- Air controlled exhaust brake.
- Air dryer.

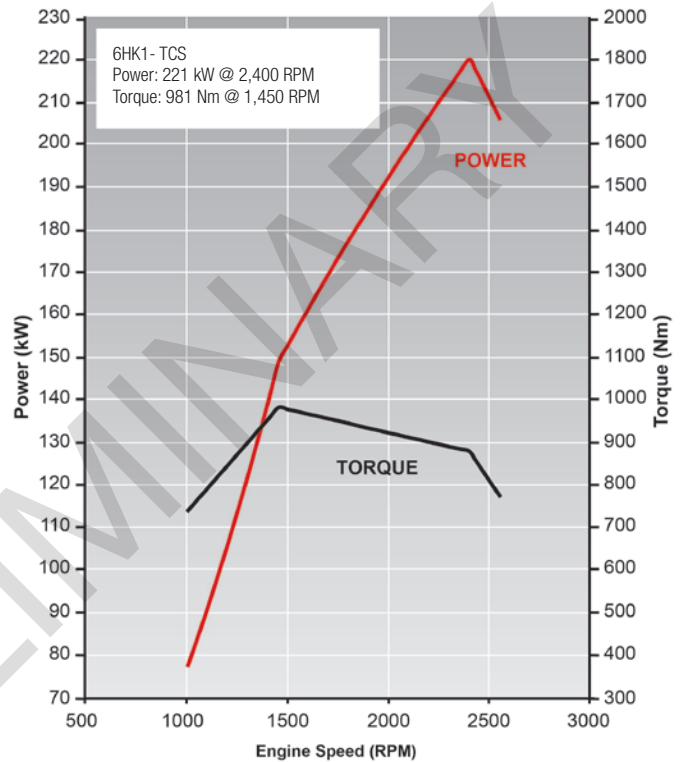

STEERING

- Power assisted recirculating ball steering. LHS and RHS control positions linked by gear driven cross shaft.
- Gear ratio: 22.4:1
- Turns lock to lock: 5.4
- Maximum angle: 45° (inside wheel) / 35° (outside wheel)

WHEELS AND TYRES

- 22.5 x 8.25 ten stud ISO standard steel wheels.
- **Steer axle:** 295/80R22.5 152/148M Michelin X Multi Z Tubeless
- **Drive axle:** 11R22.5 148/145L Michelin X Multi D Tubeless
- Maximum tyre rating:
 - Steer axle: 7,100 kg
 - Drive axle: 11,600 kg
- Spare wheel and X Multi Z tyre assembly with winch type carrier.

CHASSIS FRAME

- Cold rivetted ladder frame with parallel side rails. SAPH440 weldable steel sidemembers.
- Frame dimensions:
 - Side rail (mm): 258 x 85 x 10
 - Rear frame width (mm): 850

FUEL TANK

- Frame mounted 200L steel fuel tank.
- Lockable fuel cap.

ELECTRICAL SYSTEM

- 24 volt electrical system.
- 90 amp alternator.
- 24 Volt, 5.0 kW starter motor.
- 2 x 115E41L (651 CCA) batteries connected in series.

- Digital body controller interface. Activated by body builder and incorporates features including:
 - PTO and engine speed control
 - Airbag suspension dump control
 - Speed limiting during bin lift operations
 - CAN output for various vehicle states
 - Power connection points from vehicle lights, park brake and reverse gear selection switches, 10A battery and ignition switch supply circuits.

CABIN SPECIFICATIONS AND APPOINTMENTS

CAB EXTERIOR

- All steel construction with electro-hydraulic cab tilt. High tensile steel used for cab underframe.
- Full floating cab with coil spring suspension and hydraulic shock absorbers.
- Heavy duty high visibility safety yellow entry steps. Top step with replaceable non slip insert.
- 90° opening internally reinforced front doors.
- Water spray suppression guards and front mudflaps.
- Laminated windscreen with shade band.
- Two speed windscreen wipers, with intermittent wipe mode.
- Halogen multi-reflector headlamps incorporating turn signals and front foglamps. Additional door mounted side indicator lamps.
- Combination brake, turn, reverse and marker lamps, registration plate illumination lamps. Extended wiring harness. Reverse alarm.
- Roof-mounted clearance lamps.
- Heated and powered exterior main mirrors with flat glass and additional powered convex "spot" mirrors.
- Body coloured grille.
- Body coloured steel air dam bumper with side cornering lamps.
- FUPD underbar - complies with ECE R93
- "DUAL CONTROL" labelling at front of cab

CAB INTERIOR

- Isri 6860 air suspension driver's seat for LHS and RHS control positions. Pneumatic lumbar support, height, rake and automatic weight adjustment.
- Front passenger adjustable bucket seat and front centre seat with folding seat back.
- 3-point lap sash seatbelts integrated with seats in all outboard seating positions. RHS driver seatbelt fitted with pre-tensioner.
- ADR 42 compliant sleeper.
- RHS driver airbag
- High visibility safety yellow door pillar entry assist grips. Roof pillar assist grips.
- Full interior trim, padded roof lining and vinyl floor covering. LHS and RHS windscreen header storage shelf.
- Electrically adjustable tilt steering columns, soft feel urethane steering wheels.
- Electric windows.
- Central locking with remote keyless entry and immobiliser.
- Twin cup holders. 24V cigarette lighter.
- Front door mounted storage pockets and RHS ashtray.
- Fully integrated air conditioning and heater/demister with 4-speed fan and outlets for windscreen, side windows, face and floor.
- Fluorescent type interior lamp with On/Door/Off switch.
- 2 DIN, two speaker multimedia unit with 6.2" LCD capacitive touch screen. 1.6GHz processor with Android operating system. DAB+ digital radio and fully integrated Bluetooth with voice recognition. Inbuilt PDF, photo and movie viewer. Internet radio accessible via smartphone. 32GB internal file storage. USB and auxiliary input connection provisions. Firmware and map updates possible via smartphone.
- DIN sized compartment for storage or for CB radio installation.

SATELLITE NAVIGATION

Integrated with radio/CD multimedia unit. Displayed information includes:

- Points of interest and Isuzu truck dealer locations.
- Road safety alerts.
- Speed limits and traffic signals.
- Route selection based on entered information such as vehicle weight and dimensions.

DRIVER CONTROLS

- Key-operated centrally mounted engine start/stop. Engine idle speed control.
- Centrally mounted LHS or RHS driving position selection switch.
- DPD regeneration.
- Pushbutton gear selection control.
- **Left side combination stalk:** Windscreen wipers, washers and exhaust brake.
- **Right side combination stalk:** Turn signals, headlamps and cruise control.

INSTRUMENTATION

- Dual LHS and RHS instrument clusters operating in parallel. Electronically driven speedometer and tachometer. Digital odometer with integrated dual tripmeter. Engine coolant temperature, fuel level and air pressure gauges.
- **Warning lamps:** Check engine, oil pressure, low coolant level, ABS, SRS airbag, alternator charge, service brakes, park brake, seat belt unfastened, low air pressure, low fuel level, cab lock.
- **Indicator lamps:** Warm up system, high beam, DPD status, exhaust brake, turn signals, cruise control, LHS driver position activated.
- Gear selection display.
- Multi information display. Shows service intervals, vehicle systems status, instantaneous and average fuel consumption, DPD bar chart, hourmeter, voltmeter, time/day/date and includes 40-120km/h adjustable vehicle speed warning.

OPTIONS AND GENUINE ACCESSORIES

Include the following (extra cost, request a brochure and further details from your Isuzu dealer):

Multimedia unit:

- Supports up to five camera inputs. One digital camera with infra red and rear microphone input active when reversing. Four analogue cameras.
- Reversing sensors
- Tyre pressure monitoring system

Other:

- Roof mounted amber warning beacon with light bar
- Fire extinguisher
- Airbag compatible bullbar
- Air deflector

ISUZU CARE

Isuzu Care gives truck owners access to products and services including Roadside Assist, Service Agreements, Extended Care, Extended Isuzu Assist and the Isuzu Care Centre. Call 1800 035 640.

WEIGHTS (kg)

Models	Ratings*		Loading Limit* (at ground)		Cab Chassis Mass #		
	GVM	GCM	Front	Rear	Front	Rear	Total
FVD 165-300 MLWB Dual Control	16,500	32,000	6,600	10,400	3,695**	1,815**	5,510**

* Vehicle ratings and front/rear weight limits are subject to government regulatory requirements and weight distribution analysis. 16,500kg is maximum optional GVM rating. Consult your Isuzu dealer to select the correct vehicle for your specific application.**Calculated estimates. # Cab chassis only as supplied and including 10 litres of fuel.

DIMENSIONS (mm)

Models	WB	OAL	FOH	ROH	EA	CE	RT	ORT	CH	FFA (unladen)	RFA (unladen)	RFH (unladen)	Turn Circle (m)
													KERB TO KERB
FVD 165-300 MLWB Dual Control	5,550	9,255	1,440	2,265	4,850	7,190	1,840	2,445	2,850	1,000	1,010	1,010	19.4

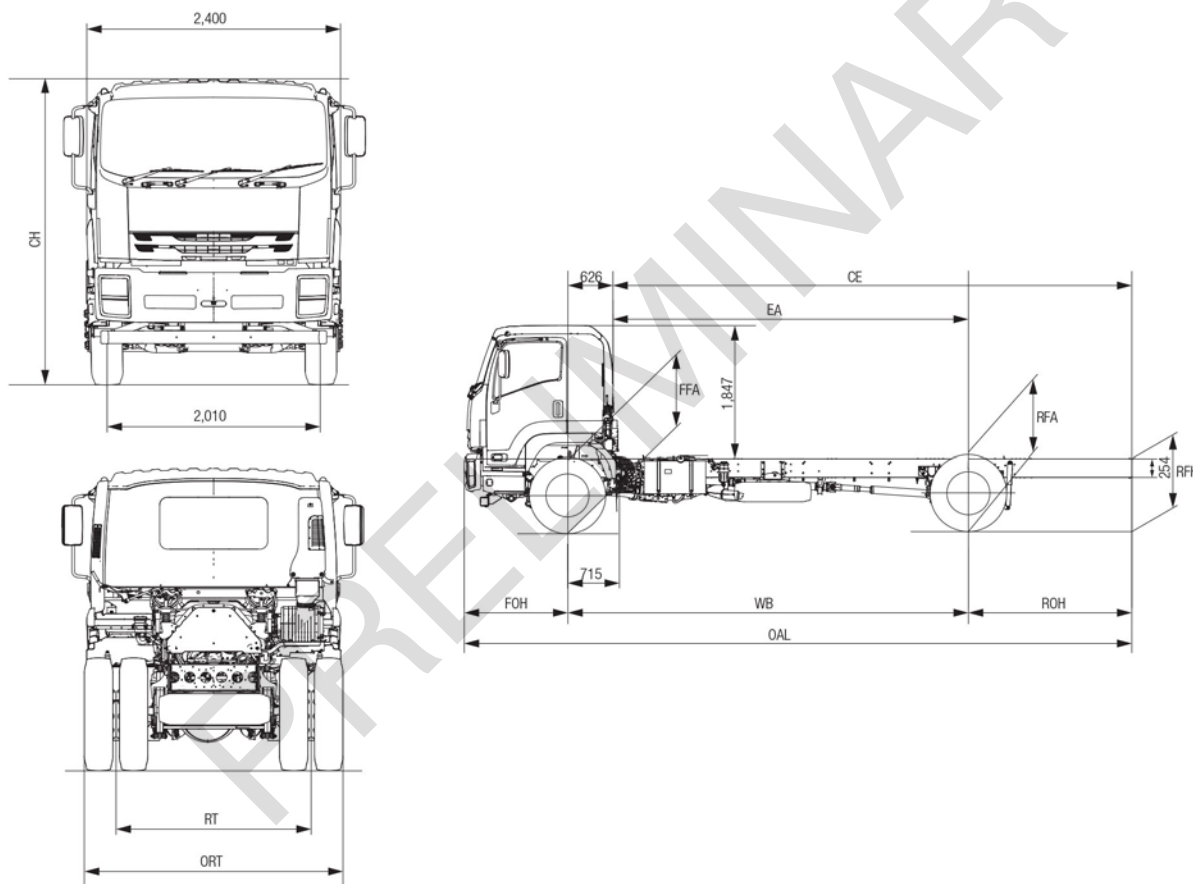

PERFORMANCE (calculated - typical paved road)

		Geared Speed* (top gear at peak power engine RPM)	Low Speed Gradeability (lowest forward gear assuming no wheel slip)	Engine Speed (top gear at 100km/h)
FVD 165-300 Dual Control	At 16,500 kg GVM	111 km/h @ 2,400 RPM	47%	2,160 RPM

* Maximum speed achievable depends on vehicle frontal area as well as other factors. Consult your Isuzu dealer for more detailed information. Vehicle is speed limited to 100km/h

ISUZU WARRANTIES

STANDARD ¹	
New Vehicle	3 years • 200,000km • 3,000 hours
Cab Perforation Corrosion	3 years • unlimited km
Isuzu Assist: 24 hour roadside assistance (3 years, unlimited km)*	
EXTENDED CARE ²	
Extended Warranty: 5 years • 350,000km • 5,500 hours	
Isuzu Assist: 24 hour roadside assistance (5 years, unlimited km)	

ORDER CODES

Model	Code
FVD 165-300 MLWB DUAL CONTROL	FH-FVDTZ-M20

¹ Subject to the conditions outlined in the IAL New Vehicle Warranty, the Isuzu FVR and FVD models carry a standard factory warranty which covers the owner: (i) for the entire vehicle, for the first 36 months or 200,000 km or 3,000 hrs (whichever comes first), (ii) against cab perforation corrosion, for 36 months and unlimited kilometres. ² Extended Warranty as illustrated may be purchased to cover the owner against the failure of original components, but may exclude some components and expendable items such as oil, filters, etc. *Valid for three years from the date of new vehicle purchases. All Isuzu warranties are subject to mandatory prescribed terms under Australian Consumer law including customer guarantees. For more details visit the Isuzu website which explains Isuzu warranties in more detail, or alternatively contact your local dealer. All warranties commence from date of delivery. ISUZU AUSTRALIA LIMITED ABN 97 006 962 572 ("IAL"). The information in this spec sheet was correct at time of printing, but all measurements, specifications and equipment are subject to change without notice. Some equipment may have been changed and/or is available at extra cost. IAL may make changes at any time without notice, in prices, colours, materials, equipment and models. IAL makes all reasonable attempts to ensure the availability of all vehicles and equipment. The information in this spec sheet is general in nature. Your Isuzu dealer can confirm all measurements, specifications and vehicle / equipment availability upon request. To the extent permitted by the law, IAL is not liable to any person as result of reliance on the content of this spec sheet.