

Model	NPR250/300
GVM	4,490kg / 6,200kg
GCM	7,990kg / 9,700kg
Engine Type:	Isuzu SiTEC 120
Displacement:	4,570 cc
Power*:	89 kW @ 3,000 RPM
Torque*:	325 Nm @ 1,800 RPM



Cab/Chassis specification as at July 2001

CABIN SPECIFICATIONS AND APPOINTMENTS

CABIN EXTERIOR

- All steel cabin with manual tilting to 45°.
- Extended front wheel arch spray suppression guards.
- 90° opening, internally reinforced doors.
- Aluminium, non-slip entry steps.
- "West Coast" type rear view mirrors. Flat mirror glass with additional, independently adjustable convex "spot" mirror on both sides.
- Access to fluid check points without tilting cab.
- Tinted and laminated windshield.
- 2-speed windshield wiper system with intermittent wipe mode. Windshield washer system with triple washer jets on each wiper arm.
- Single-piece headlamps, incorporating turn signals.
- Roof-mounted clearance lamps.

CABIN INTERIOR

- Entry assist handles on 'A' pillars.
- Passenger side assist grip.
- Driver's bucket seat with reclining back and fore-aft adjustment. 2-person passenger bench seat with folding seat back. Seat cushion tilts for access to engine. Fire resistant cloth seat facings.
- 3-point, lap-sash seatbelts with emergency locking belt retractors in outboard seating positions. 2-point lap seatbelt in centre seating position.
- Driver and passenger fold-down sun visors.
- Interior rear-vision mirror.
- Full interior panel trim with padded roof lining and vinyl floor mats. Windscreen header storage shelf.
- "Glove" compartment with door.
- "Soft feel" urethane steering wheel.
- Steering column with tilt and telescopic adjustment.
- Heater / Demister with 4-speed fan and windscreen, face and floor outlets. Fore-aft adjustable roof vent.
- Optional fully integrated air conditioning.
- AM / FM Stereo Radio / Cassette with integrated digital clock.
- Optional 6 stack CD player.
- Centre fascia pull-out drinks holder.
- Easy access fuse panel (behind glove compartment door).
- Windshield washer reservoir under glove compartment.

- Centre fascia and driver's doorash trays.
- Interior lamp with On / Door / Off switch, activated by either door.

CONTROLS

- Key-operated engine start / stop and steering lock. Engine fast-idle vernier.
- Left Side Combination Stalk: Windshield wipers and washer.
- Right Side Combination Stalk: Turn signals; position, main and high beam lamps. Hazard flash switch.
- Additional interior lamp switch on instrument panel adjacent to driver's door.

INSTRUMENTATION

- Gauges: Electronically driven speedometer and tachometer. Digital odometer with integrated, dual tripmeter. Engine coolant temperature and fuel level.
- Warning Lamps: Low battery charge, brake failure, low fuel level, glow plug, water separator.
- Indicator Lamps: Turn signals, parking brake, high beam.

TOOLS

- Chassis frame mounted spare wheel and tyre winch. Wheel changing tools including 4,000 kg capacity hydraulic jack. Hand tools in kit bag.
- Externally mounted tool box with foam insert to support jack.

ISUZU NEW TRUCK WARRANTIES

	STANDARD TRUCKPOWER WARRANTY*		TRUCKPOWER EXTENDED WARRANTY OPTIONS#		
NEW VEHICLE	2 years	50,000km	3 years / 100,000km	4 years / 150,000km	5 years / 200,000km
DRIVETRAIN	3 years	100,000km			
CAB CORROSION	3 years	unlimited			

* Subject to the conditions outlined in the I-GM New Vehicle Warranty, the Isuzu NPR models carry a standard factory warranty which covers the owner: (i) for the entire vehicle, for the first 24 months or 50,000km (whichever comes first) (ii) for the powertrain, which runs concurrently, for 36 months or 100,000km (whichever comes first) (iii) against cab corrosion, for 36 months and unlimited kilometres.

A TruckPower Extended Warranty as illustrated is available by purchase to cover the owner against the failure of original components, but excludes some components and expendable items such as oil, filters, etc. Please consult with your Isuzu Dealer for full details obtainable from a dedicated brochure available to customers.

ISUZU
RELIABILITY IS EVERYTHING

ISUZU-GENERAL MOTORS AUSTRALIA LTD A.C.N. 006 962 572. PLEASE NOTE: as the policy of I-GM is one of continual product improvement, all specifications and equipment are subject to change without notice. No I-GM dealer or other person is authorised or permitted to give or make any statement, assertion or undertaking in relation to the quality, performance, characteristics, descriptions or fitness for any purpose of any I-GM product or in connection with the supply of any I-GM product which is at variance with any written statement, assertion or undertaking on any of these subjects given or made by I-GM in its published sales literature, and the company accepts no liability for any such unauthorised action. I-GM has franchised dealers in many parts of Australia, for the sale of service, parts and the provision of service to the owners of I-GM products. Every endeavour is made to ensure that such dealers carry adequate stocks of service parts and are equipped to provide satisfactory service, but makes no promise, other than that contained in the I-GM new vehicle warranty, that such parts or service facilities will be available or available at any specific location or at any particular time. A word about this specification sheet. We have tried to make it as comprehensive and factual as possible. However, since the time of printing some of the information you will find here may have been updated. Also, some of the equipment shown or described through this specification sheet may have been changed and/or is available at extra cost. And the right is reserved to make changes at any time without notice, in prices, colours, materials, equipment and models. Your I-GM dealer has details and before ordering, you should ask him/her to bring you up to date.

DRIVELINE SPECIFICATIONS

ENGINE: SİTEC 120 TURBO (ISUZU 4HG1-T)

Type: 4 cylinder, 4 stroke, overhead camshaft, turbocharged, direct injection diesel.

Bore x Stroke: 115 mm x 110 mm

Displacement: 4,570 cc

Compression Ratio: 19.0:1

Output Power*: 89 kW @ 3,000 RPM

Torque*: 325 Nm @ 1,800 RPM

Emissions Standard: Euro 2

* Engine performance to EEC 80/1269 (Nett).

- Integral engine oil cooler.
- Electronically controlled Exhaust Gas Recirculation (EGR) system.
- Separate full-flow and bypass engine oil filters.
- Bosch 'A' type fuel injection pump with 'RLD' all-speed governor. Quick-start glow plug cold starting aid.

COOLING SYSTEM

- Pressurised cooling system. Tube and corrugated fin type radiator with 2,447 cm² frontal area.
- 10-blade, plastic, 430 mm diameter cooling fan with thermostat / viscous type clutch.

AIR INTAKE SYSTEM

- Chassis mounted, cartridge type, 197 mm diameter air filter. Vertical air intake stack and resonator mounted at cabin rear.

EXHAUST SYSTEM

- Horizontal exhaust silencer. Chassis mounted, vertical exhaust stack.

FUEL SYSTEM

- Cylindrical, steel fuel tank with 115 litre liquid capacity and 10 litre expansion space. Total:125L
- Fuel / water separator with warning lamp.
- Single stage fuel filter.

CLUTCH

- Hydraulically actuated, 300 mm diameter, dry single plate with 8 coil cushioning springs, single diaphragm pressure spring. Asbestos free clutch lining material. Total lining area 847 cm².
- Automatic clutch adjuster (manual models).

TRANSMISSION: ISUZU MXA-5R MANUAL:

- 5 forward speeds including overdrive, 1 reverse speed, synchromesh on all gears. P.T.O. opening left hand side.

Gear Ratios:

1st	2nd	3rd	4th	5th	Rev
4.987:1	2.870:1	1.594:1	Direct	0.728:1	4.774:1

- Maximum Geared Speed:116 km/h @ 3,400 RPM
- 2-piece propeller shaft with 82.6 mm tube diameter.

TRANSMISSION: JATCO JR 403E AUTOMATIC:

- Electronically controlled automatic transmission with 4 forward speeds including overdrive, 1 reverse speed, torque converter clutch. Floor mounted control lever that may be folded down in "Park" position. Driver selectable, "Laden" and "Unladen" gear shift schedules and overdrive ratio lockout. P.T.O. opening left hand side. P.T.O. gear driven by torque converter turbine.
- 300mm diameter torque converter. 2.01:1 Converter Stall Ratio.
- Gear Ratios:

1st	2nd	3rd	4th	Rev
3.068:1	1.570:1	Direct	0.724:1	2.625:1

- Maximum Geared Speed: 117 km/h @ 3,400 RPM
- 2-piece propeller shaft with 82.6 mm tube diameter.

FRONT AXLE: ISUZU F027

- Reverse Elliot I-Beam with 2,700 kg capacity.
- 30 mm diameter king-pin with ball type thrust bearing.

REAR AXLE: ISUZU R050

- Banjo type with full floating axle shafts.
- Axle tube size: 106 mm x 106 mm x 6 mm
- Rated capacity: 5,000 kg
- Single reduction, hypoid gearing with 292 mm ring gear and 4-pinion differential. Drive ratio: 5.857:1

CHASSIS SPECIFICATIONS

CHASSIS FRAME

- Parallel I section rails with cold rivetted cross members forming ladder type frame. Top flange of chassis rail is rivetless.
- Rail dimensions:
Web mm: 216 x 6.0
Flanges mm: 70 x 6.0
- Frame width: 850 mm

SUSPENSION

FRONT

- Alloy steel, multi-leaf springs with fully wrapped eye and metalastic bushes. Nominal size: 1,300 mm x 70 mm
- Hydraulic, double acting, telescopic shock absorbers.
- Stabiliser bar.

REAR

- Alloy steel, multileaf, two-stage springs. Fully wrapped main spring eyes with metalastic bushes. Nominal spring lengths: Main spring: 1,350 mm x 70 mm
Auxiliary spring: 850 mm x 70 mm
- Hydraulic, double acting, telescopic shock absorbers.

BRAKES - MANUAL TRANSMISSION

- Front and rear drum brakes with dual circuit hydraulic control,

vacuum assistance and load sensing proportioning valve.

Front Drum Diameter: 320 mm

Rear Drum Diameter: 320 mm

- Slave cylinder / shoe types:
Front: Two leading, manual adjust.
Rear: Dual two leading, manual adjust.
- Asbestos free brake linings.
- Lining size (per wheel end):
Front: 2 x 307 mm x 75 mm x 9.6 mm
Rear: 2 x 307 mm x 75 mm x 9.6 mm

BRAKES - AUTOMATIC TRANSMISSION

- Front ventilated disc brakes with twin piston calipers. Rear drum brakes. Dual circuit hydraulic control, vacuum assistance and load sensing proportioning valve. Front Disc Outer Diameter: 293 mm
Rear Drum Diameter: 320 mm
- Rear slave cylinder / shoe type: Dual two leading with automatic adjustment. Asbestos free brake pad and shoe lining material.
- Lining size (per wheel end):
Front Pads: 2 x 180 cm² x 14.0 mm
Rear: 2 x 335 mm x 100 mm x 11.0 mm

Exhaust brake

- Electro-vacuum controlled, butterfly type, 70 mm diameter exhaust brake.

- Drum parking brake on transmission output shaft. Control lever floor-mounted LHS of drivers seat.

STEERING

- Integral power assisted, recirculating ball type steering. Lube-for-life drag link. Gear driven, vane type oil pump.
- Gear ratio: 20.9:1
- Turns lock to lock: 4.9

WHEELS AND TYRES

- 6.00GS x 16 JIS 5 stud disc wheels.
- 7.50R16LT 8 P.R. Goodyear G114A tyres.
- Total of 7 wheels and tyres supplied including 1 spare wheel and tyre assembly.

ELECTRICAL SYSTEM

- Batteries: 2 x 12 Volt / 65 Amp-Hour batteries in series for 24 Volt, negative ground system. Alternator: Hitachi 24 Volt / 50 Amp brushless type.
- Starting Motor: Hitachi 24 Volt / 4.0 kW reduction geared type.
- Rear brake, turn, reverse and marker lamp assemblies and rear registration plate lamp with additional wiring lengths. Reversing alarm.

MODEL RATINGS AND DIMENSIONS

TOWING CAPACITY

750kg (Unbraked trailer)

3,500kg (Braked trailer)

MODELS	RATINGS		TARE MASS [#]			DIMENSIONS (mm)											TURNING CIRCLE
	GVM	GCM	TOTAL	FRONT	REAR	WB	OAL	FOH	ROH	CA	CE	CW	CH	FFH LADEN	RFH LADEN	KERB TO KERB	
NPR250 Medium	4,490kg	7,990kg	2,370kg	1,570kg	800kg	3,365	5,955	1,085	1,505	2,640	4,345	1,995	2,240	685	770	12.3m	
NPR300 Medium	6,200kg	9,700kg	2,370kg	1,570kg	800kg	3,365	5,955	1,085	1,505	2,640	4,345	1,995	2,240	685	770	12.3m	
NPR250 Auto	4,490kg	7,990kg	2,430kg	1,610kg	820kg	3,365	5,955	1,085	1,505	2,640	4,345	1,995	2,240	685	770	12.3m	
NPR300 Auto	6,000kg	9,500kg	2,430kg	1,610kg	820kg	3,365	5,955	1,085	1,505	2,640	4,345	1,995	2,240	685	770	12.3m	

[#]Estimated mass of cab/chassis with oil, water and fuel tank containing 10 litres of fuel and including spare wheel and tools.

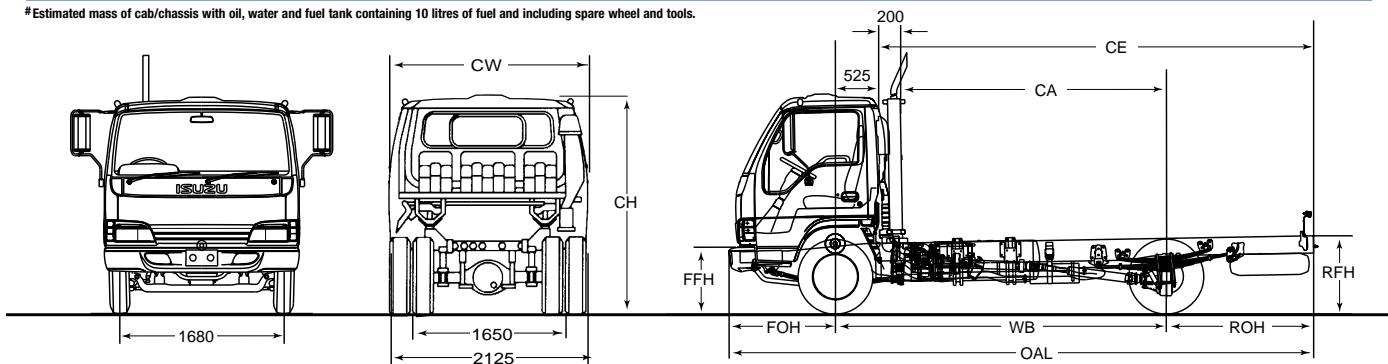

For further information regarding Cab/Chassis dimensions your Isuzu Dealer can access detailed Body Builders diagrams from the Isuzu Truck Data Manual.