

# ISUZU FVR Turbo 950

- LONG
- LO-PROFILE

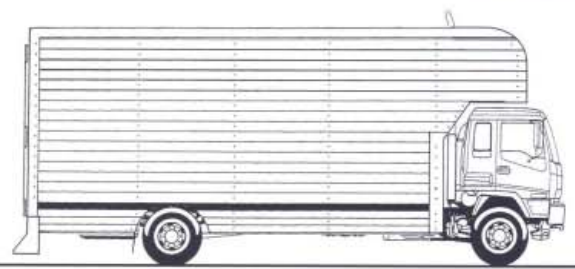
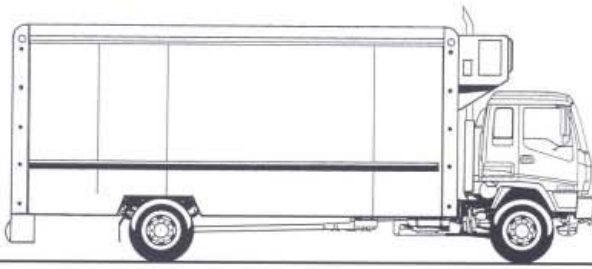

## ENGINE ISUZU 6SD1-TC

**Type:** 6 cylinder, in line, overhead camshaft, direct injection, four stroke, diesel engine. Turbocharged and Air-To-Air Intercooled.

**Bore x Stroke:** 120 mm x 145 mm

**Displacement:** 9839 cc

**Compression Ratio:** 16.5:1

**Output - Power:** 199 kW @ 2200 RPM (ISO 1585)

**Torque:** 1,000 Nm @ 1500 RPM (ISO 1585)

## CLUTCH

- Hydraulic control dry single plate with cushioning springs. Coil type pressure springs. Clutch disc diameter: 381 mm (15").
- Pneumatic clutch release assistance.
- Asbestos free lining material. Total lining area 1,363 cm<sup>2</sup>.

## TRANSMISSION EATON FS-8209

- Direct drive transmission. 8 synchronised, regular usage forward speeds. One forward crawler speed. 1 reverse speed.
- 'Repeat-H' shift pattern. Pre-selected and synchronised range change. Oil capacity 8.5 litres.

Gear ratios (:1)

<b>Low</b>	<b>1st</b>	<b>2nd</b>	<b>3rd</b>	<b>4th</b>
12.64	8.81	6.55	4.77	3.55
<b>Rev</b>	<b>5th</b>	<b>6th</b>	<b>7th</b>	<b>8th</b>
13.21	2.48	1.85	1.34	1.00

- Maximum geared speed:  
FVR 950 TURBO LONG 115 km/h.  
FVR 950 TURBO LO-PROFILE 105 km/h.
- Electronically road speed limited to 100 km/h.

## REAR AXLE ROCKWELL RS-23-160 CAPACITY 10,500 KG

- Banjo, fully floating, single reduction type. Final drive ratio 3.909:1
- Hypoid type ring gear 457 mm diameter. Oil capacity 15.0 litres.

## BRAKES

- Rockwell 'Q-Plus' full air, 'S'-cam, dual circuit brake system with front and rear leading and trailing shoes. Asbestos free brake shoe lining material. Drum diameters (front and rear): 419 mm.
- Brake drum swept areas:  
8,688 cm<sup>2</sup> total: 4,002 cm<sup>2</sup> front, 4,686 cm<sup>2</sup> rear.
- Air reservoir capacities:  
Supply Tank Front Service Tank Rear Service Tank  
28.5 litres 19.5 litres 19.5 litres
- Parking Brake Tank  
11.0 litres.
- Air Compressor 85 mm Bore x 60 mm Stroke (340 cm<sup>3</sup> / revolution), gear driven at half engine speed, water cooled.
- Nylon brake air tubing.
- Spring park brake acting on rear wheels.
- Air controlled, butterfly type exhaust brake.

FVR 950 MODEL:	WHEELBASE	GVM	GCM	ORDERING CODE
LONG	6,050 mm	16,000 kg	32,000 kg	SFS02-681
LO-PROFILE	6,050 mm	16,000 kg	32,000 kg	SFS02-684

## KERB MASS (kg)\*

\*Estimated mass of chassis cab with oil, water and fuel tank containing 10 litres of fuel. Excluding spare wheel and tools.

FVR 950 Model:	Front	Rear	Total
LONG	3,175	2,180	5,355
LO-PROFILE	3,155	2,150	5,305

## DIMENSIONS (mm) \*

	LONG	LO-PROFILE
Wheelbase (WB)	6,050	6,050
Overall Length (OAL)	10,020	10,020
Rear Overhang (ROH)	2,700	2,700
Cab To Axle (CA)	5,340	5,340
Cab To End Of Frame (CE)	8,040	8,040
Front Frame Height, Unladen (FFH)	950	910
Front Frame Height, Laden (FFH)	905	865
Rear Frame Height, Unladen (RFH)	1,045	1,005
Rear Frame Height, Laden (RFH)	980	940
Turning Circle (Kerb To Kerb)	22.5m	22.5m
Nominal Max. Body Length*	8,395	8,395

\*Except Turning Circle: metres. \*Subject to weight distribution

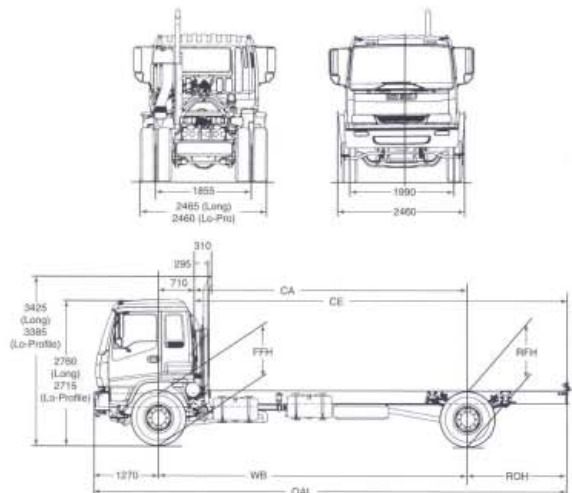

ISUZU GENERAL IMPORTS AUSTRALIA (Pty) Ltd, 900 900 372. Subject to the conditions of the ISUZU New Vehicle Warranty, every Isuzu Turbo F-Series Truck carries a warranty which covers your vehicle for the first 24 months or 120,000 km (whichever comes first). A 36 month or 200,000 km (whichever comes first) power train warranty (includes engine and transmission) will be given (with the maximum of 24 months or 120,000 km) on all Isuzu Turbo F-Series Trucks. PLEASE NOTE: as the policy of ISUZU is one of continual product improvement, all specifications and equipment are subject to change without notice. All body illustrations are based on the standard equipment. No ISUZU dealer or other person is authorized or permitted to give or make any statement, assertion or undertaking in relation to the quality, performance, characteristics, description or fitness for any purpose of any ISUZU product or to assume responsibility for the quality of any ISUZU product which is or may be used with any other machine, accessories or undertaking or use of these vehicles, parts or tools. ISUZU are published sales literature, and the company accepts no liability for any such misstatements or omissions. ISUZU has franchise dealers in many parts of Australia, for the sale of new parts and the provision of services to the owners of ISUZU products. Every endeavour is made to ensure that such dealers carry adequate stocks of service parts and are equipped to provide satisfactory service, but makes no guarantee, other than that contained in the ISUZU new vehicle warranty, that such parts or services facilities will be available or available at any specific location or at any particular time. A warning about this specification sheet: We have tried to make it as comprehensive and factual as possible. However, since the time of printing some of the information may well have been updated. Also, some of the equipment shown or described through this specification sheet may have been changed and/or is available at extra cost. And the right is reserved to make changes at any time without notice, to prices, colours, materials, equipment and models. Your ISUZU dealer has details and before ordering, you should ask him/her to bring you up to date.

# ISUZU

RELIABILITY IS EVERYTHING



## AIR INTAKE SYSTEM

- Donaldson 13" diameter, dry element, two stage filter. Vertical intake stack with rain head. Turbocharger and Air-To-Air Intercooler. Intercooler dimensions: 540 mm x 470 mm x 53 mm. Total intercooler frontal area 2,540 cm<sup>2</sup>.

## CHASSIS FRAME

- Parallel rail, ladder type, channel section, cold riveted.
- Straight frame for easy body mounting. 850 mm frame width.
- Rear crossmember and spring hanger brackets bolted to frame allowing easy wheelbase modification. Frame side member dimensions: 258 mm x 85 mm x 10 mm.
- Frame reinforcement angle section: 224 x 85 x 4.5 mm.
- Frame material: SAPH440 weldable mild steel.

## COOLING SYSTEM

- 6 blade plastic cooling fan 600 mm diameter with bell-mouth fan shroud and dual drive belts. Bimetallic controlled, thermatic fan clutch.
- Tube and corrugated fin, pressure type radiator. Dimensions: 800 mm x 636 mm x 54 mm. Frontal area 5,088 cm<sup>2</sup>. Coolant capacity 29.0 litres.

## ELECTRICAL SYSTEM

- Batteries: 2 x 12 Volt / 65 Amp/h, negative earth.
- Alternator: 24 Volt / 40 Amp.
- Starting Motor: 24 Volt / 5.5 kW.
- Rear stop, turn, reverse and tail lamp assemblies and licence plate lamp with long leads for variable body mounting.

## EXHAUST SYSTEM

- Horizontal muffler with vertical exhaust pipe.
- Air controlled, butterfly type exhaust brake.

## FRONT AXLE ISUZU F063 CAPACITY 6,300 KG

- Reverse Elliot I-beam type.
- King Pin diameter 50 mm with cylindrical roller thrust bearing. Oil bath lubricated front wheel hubs with see-through oil level indicator.

## FRONT SUSPENSION CAPACITY 6,000 KG

- Semi-elliptical, alloy steel tapered multi-leaf springs. Fully wrapped spring eye with greasable shackles.

Length	x	Width	x	Thickness	x	No. leaves
1,470 mm	x	80 mm	x	12 mm	x	2
		80 mm	x	13 mm	x	5
		80 mm	x	11 mm	x	2

- Stabiliser bar.
- Hydraulic, double acting, telescopic shock absorbers.

## FUEL SYSTEM

- In line plunger, Bosch 'AP' type fuel injection pump with 'RLD' mechanical all-speed governor. Electronic road speed limiter.
- In line, paper element filter. See-through water separator with drain cock. Fuel Tank Fitment:  
FVR 950 TURBO LONG Dual 180 litre capacity.  
FVR 950 TURBO LO-PRO Single 180 litre capacity.

## LUBRICATION SYSTEM

- Pressure feed lubrication system. Gear driven, gear type oil pump. Full-flow and partial-flow bypass oil filter canisters.
- Plate type oil cooler in engine water jacket.
- Oil capacity 28.5 litres (including filters).

## PROPELLER SHAFT

- 3-piece, 114.3 mm diameter propeller shaft with 2 support bearing assemblies. 1st Section Length: 977 mm  
2nd Section Length: 1,357 mm  
3rd Section Length: 1,339 mm

## REAR SUSPENSION CAPACITY 10000 KG

- Semi-elliptical, alloy steel tapered multi-leaf springs. Fully wrapped spring eye with greasable shackles.
- |            | Length   | x | Width  | x | Thickness | x | No. leaves |
|------------|----------|---|--------|---|-----------|---|------------|
| Main:      | 1,420 mm | x | 100 mm | x | 12 mm     | x | 8          |
| Auxiliary: | 980 mm   | x | 100 mm | x | 10 mm     | x | 2          |
|            |          |   | 100 mm | x | 11 mm     | x | 4          |

- Stabiliser bar.

## STEERING

- Fully integral power assisted recirculating ball and nut type. Gear ratio 22.4:1. Turns lock to lock: 4.5. Gear driven, vane type oil pump. See-through oil reservoir.
- Oil capacity 2.5 litres (including reservoir).

## TOOLS

- Lockable tool box with 10,000 kg capacity jack. Wheel changing tools. Tool kit.

## WHEELS AND TYRES

- 8.25 x 22.5 - 10 stud ISO standard (hub piloted) disc wheels. Stud size: 22 mm. Offset: 165 mm. Goodyear G391 tubeless radial tyres fitted front and rear.
- Tyre Size:  
FVR 950 TURBO LONG 11R22.5-16 Ply Rating.  
FVR 950 TURBO LO-PRO 275/70R22.5-16 Ply Rating.
- Winch type spare wheel carrier, mounted on chassis frame on passenger side. Number of wheels and tyres: 7 (including spare).

## CABIN EXTERIOR

- All steel cab with welded strengthening ribs and side door impact beams. Torsion bar assisted cabin tilt to 45°.
- Four point cabin suspension utilising silicone filled rubber isolators.
- Cation electrodeposition primer.
- Heavy duty bumper bar with step holes and footplate.
- Halogen headlamps, hinged for easy bulb replacement.
- Park lamps and cabin clearance lamps.
- Turn signal lamps in front bumper and over wheel arches.
- 2 speed windscreen wiper / washer system with variable intermittent mode. Triple washer jets mounted on wiper arms.
- Tinted and laminated windscreen. Tinted and toughened side and rear glass.
- 'West Coast' type rear view mirrors. Convex mirror surface on passenger side.
- Alloy, non-slip cabin entry steps.
- Lift-up front panel for access to clutch and windscreen washer fluids without tilting the cabin. Engine fluid check points at rear of cabin.

## CAB INTERIOR

- Fully trimmed cab interior with cloth seat facings, formed roof lining and overhead storage lockers. Driver and passenger sun visors.
- Pull-out drinks holder in centre fascia. Cigarette lighter (24 Volt). Ash trays in doors.
- Driver's seat with mechanical suspension and 3-position lumbar support mechanism. Adjustment for fore-aft position, seat back recline and driver weight.
- Outboard reclining passenger seat with under seat storage drawer. Folding centre seat back with lockable compartment and tray.
- Outboard lap/sash seat belts with emergency locking retractors, centre lap seat belt.
- Tilt/telescopic adjustable steering column with single release lever. Soft feel urethane steering wheel with zero offset to driver's seat.
- Easy entry grab handles on 'A' and 'B' pillars.
- Heater/Demister with 4 speed fan, 4 outlet vents to screen, 5 fascia outlets, 5 foot outlets, demister ducts to door glass.
- Optional fully integrated air conditioning.
- Dash mounted AM/FM Radio Cassette with digital clock.
- DIN standard aperture in dash for CB radio.
- Park brake activation lever at left side of driver's seat.
- Combination passenger-side dash storage tray/fuse panel cover.
- Interior rear vision mirror.
- Passenger side assist grip.
- Driver's left foot rest.
- Exhaust vents at rear/upper of cabin.
- Business card clip. Coat hook at rear of cabin.
- Elastic mesh pocket on driver's door.
- 24 Volt, 2-Pin accessory plug in centre console.

## INSTRUMENTATION

- Speedometer, Odometer, Trip Meter and Tachometer.
- Coolant Temperature and Fuel Level Gauges. Dual brake air pressure gauge.

## INDICATOR LAMPS

- Turn Signals On; Parking Brake On; High Beam On; Exhaust Brake Enabled.

## WARNING LAMPS AND ALARMS

- Warning lamps for: Low Battery Charge; Low Engine Oil Pressure; Low Air Pressure; Stop And/Or Tail Lamp Failure.
- Warning lamp bulb check switch.
- Reversing Lamps and audible alarm.

## CONTROLS

- Left side combination stalk control for exhaust brake, windscreen wipers and washers and hazard lamps.
- Right side combination stalk control for headlamps, high beam and turn signals.
- Engine idle speed adjust control.
- Key operation for engine start and stop. External engine crank switch for service when cab is tilted.
- Three way switch for interior lamp (Off / On / On By Driver Or Passenger Door).

**FVR 950 TURBO** • Long  
• Lo-Profile

**ISUZU**  
RELIABILITY IS EVERYTHING