



Isuzu JCR 420S/500S



Chassis/Cab Turbocharged

GVM 12,850 kg – 13,350 kg with 9.00 x 20 – 14 ply tyres

Engine:

Model: Isuzu 6BDIT Diesel engine.
 Type: Four cycle, water cooled, overhead valve, in-line, direct injection, with turbocharger: AiResearch model T04B.
 No. of cylinders: 6.
 Bore and stroke: 102 mm x 118 mm.
 Displacement: 5785 cm³ (353 CID).
 Max. net power: 128 kW @ 3,000 rpm (DIN).
 Max. net torque: 431 Nm @ 1,900 rpm (DIN).
 Compression ratio: 17.5:1.
 RAC rating: 39.

Air Cleaner:

Vertical air intake system. Donaldson air cleaner.

Axle, Front:

Capacity: 5,000 kg.
 Type: Reverse Elliot, I-beam.

Axle, Rear:

2 speed.
 Capacity: 9,200 kg.
 Type: Fully floating axle shafts.
 Ratio: 6.018/7.631 two-speed control-air shift with electric solenoid actuation.

Brakes, Service:

Type: Hydraulic with air assisted, front-two leading, rear-dual two leading type.
 Total lining area: 3944 cm².

Brake, Parking:

Type: Mechanical internal expanding at rear of transmission.

Clutch:

Type: Dry single plate with 6 cushioning springs hydraulically operated.
 Total frictional area: 966 cm².
 Size: Outside diameter 350 mm.

Cooling System:

Radiator: Tube and corrugated fin, pressured type.
 Frontal area, radiator: 2959 cm².
 Core Thickness: 70 mm.

Drive Line:

Type: Tubular shaft, needle bearing universal joint.

Electric System:

Battery: 2 x 12 volt.
 Capacity: 65 amp./hr. each battery. Negative earth.
 Alternator: 24 volt/400 watt – 24 volt/480 watt.
 Starter: 24 volt/3.7 kW.

Frame:

Type: Ladder type channel section.
 Frame width: Front 840 mm. Rear: 800 mm.
 Side member dimensions: Depth x Width x Thickness – 225 mm x 70 mm x 6 mm.
 Frame reinforcement: Full inner channel plating in area or rear axle. Inner upright "L" plating to the rear of the cab.

Engine Lubrication:

Pressure feed with full-flow paper element. Oil cooler.
 Capacity: 14.5 litres.

Fuel System:

Injection pump: Reformed Bosch in-line with mechanical governor.
 Fuel tank capacity: 200 litres.

Springs:

Type: Semi-elliptical alloy steel leaf-springs.
 Size: Length x width. No. of leaves.
 Front: 1300 mm x 70 mm – 8.
 Rear: 1420 mm x 80 mm – 9.
 Rear auxiliary: 1000 mm x 80 mm – 7.
 Shock absorbers: Hydraulic double acting telescopic at front.

Steering:

Type: Recirculating ball with integral power assistance.
 Gear ratio: 20.8:1.

Transmission: Isuzu MBF5C

2-speed rear axle. 5 speed synchromesh on 2nd, 3rd, 4th, 5th gears. Floor mounted remote control. Power take-off with control cable.

Ratios: (to 1).

1st	2nd	3rd	4th	5th	Reverse
6.890	3.918	2.419	1.569	1.000	6.304

Wheels and Tyres:

Dual rear wheels.
 Wheels and rims: 7.00 x 20, 8 stud disc.
 Tyres: 9.00 x 20 – 12 ply. Optical: 9.00 x 20 – 14 ply.
 Spare wheel and tyre standard.

Standard Equipment:

All steel cab (tilt type) with wide windshield. Adjustable driver seat. Two-speed windshield wiper. Windshield washer. Hazard warning flasher. Dual Tone electric horn. Hydraulic jack and wheel wrench. Floor mat. Speedometer with odometer. Meter for fuel, water, temperature. Warning lamp for charging, oil pressure, and clogged oil filter, instruments for measuring air pressure and an air pressure warning lamp. Indicator lamp for turn signal, main beam, parking brake. Starter heater control. Laminated windshield glass. Spare tyre carrier. Heater and demister. Radio, General hand tools. Front wheel steps. Seat belts. External West Coast rear view mirrors.

GMH 12/20 Warranty:

Every Isuzu is covered by the GMH Warranty which covers your vehicle for the first 12 months or 20,000 kilometres.



Reliability is Everything

Isuzu JCR 420S/500S

DIMENSIONS/CHASSIS WEIGHTS

	JCR 420S		JCR 500S	
LENGTHS:		mm		mm
Wheelbase	WB	4200		5000
Front overhang	FOH	1260		1260
Rear overhang	ROH	1900		2200
Bumper - back of cab	BBC	2075		2075
Vert. exhaust-axle	VA	3150		4250
Vert. exhaust-to end of frame	VE	5050		6450
Overall length	OAL	7360		8460

WIDTHS: JCR 420S/500S			
Frame width	FW		800
Front track	FT		1920
Inside rear track	IRT		1450
Outside rear track	ORT		2285
Overall width	OAW		2370

HEIGHTS:			
Overall height (approx.)	OAH		2475
Rear axle clearance (approx.)	B		245
Frame height	FH		980

TURNING CIRCLE:			
Kerb to kerb			metres 16.8

For the most effective utilisation of this vehicle, the following guidelines should be observed to ensure that the unit is correctly applied and design limits are not exceeded.

1. The trucks are primarily designed for rigid application, but have sufficient power for occasional trailer towing.
2. Due to modern design, the low tare weight of the truck allows capacity over 9 tonnes for body, equipment and payload, within its standard G.V.M. rating.
3. This model has excellent power from its fuel-efficient, direct injection, turbocharged engine. However, large frontal area and high speed requires a great deal of power, and so the total height by width of the vehicle should generally not exceed 7.5 square metres, except for special applications.
4. High centre of gravity of bodies and loads tends to induce leaning on cornering at speed or on transverse slopes.

5. If these models are to be used as tippers, frame modifications should be made in accordance with GMH instructions. Refer to your Dealer for details.

6. Wheelbase alterations require GMH approval.

7. When P.T.O. equipment is fitted, design limits for the specified Isuzu P.T.O. must not be exceeded.

8. Special application approval from GMH Sales Department is required in writing for any deviation from standard specification, GMH wish to keep a record of special application vehicles.

Calculated maximum rolling (restart) gradeability at 12,850 kg
GVM = 30% (20%) 18,850 kg GCM = 20% (11%)

Note that restart gradeability relies on less quantifiable factors such as driver skill, frequency of restarts, vehicle condition, road surface, etc.

Maximum body dimensions	JCR 420S	JCR 500S
Length	5550 mm	6750 mm
Width	2500 mm	2500 mm
Height (as van body)	2100 mm	2100 mm

PLEASE NOTE: As the policy of General Motors-Holden's is one of continual product improvement, all specifications and equipment are subject to change without notice. Bodies illustrated are not standard.

No GMH Dealer or other person is authorised or permitted to give or make any statement assertion or undertaking in relation to the quality performance characteristics descriptions or fitness for any purpose of any GMH product or in connection with the supply of any GMH product, which is at variance with any written statement assertion or undertaking on any of these subjects given or made by General Motors-Holden's Limited or General Motor-Holden's Sales Pty. Ltd. in its published sales literature, and neither company accepts any liability for any such unauthorised action.

General Motors-Holden's Limited and General Motors-Holden's Sales Pty. Ltd. have franchised dealers in many parts of Australia for the sale of service parts and the provision of service to owners of GMH's products. Every endeavour is made to ensure that such dealers carry adequate stocks of service parts, and are equipped to provide satisfactory service, but neither General Motors-Holden's Ltd. nor General Motors-Holden's Sales Pty. Ltd. makes any promise, other than that contained in the New Vehicle Warranty given by General Motors-Holden's Sales Pty. Ltd., that such parts or service facilities will be available, or available at any specific location or any particular time.

General Motors Holden's Sales Pty. Ltd.

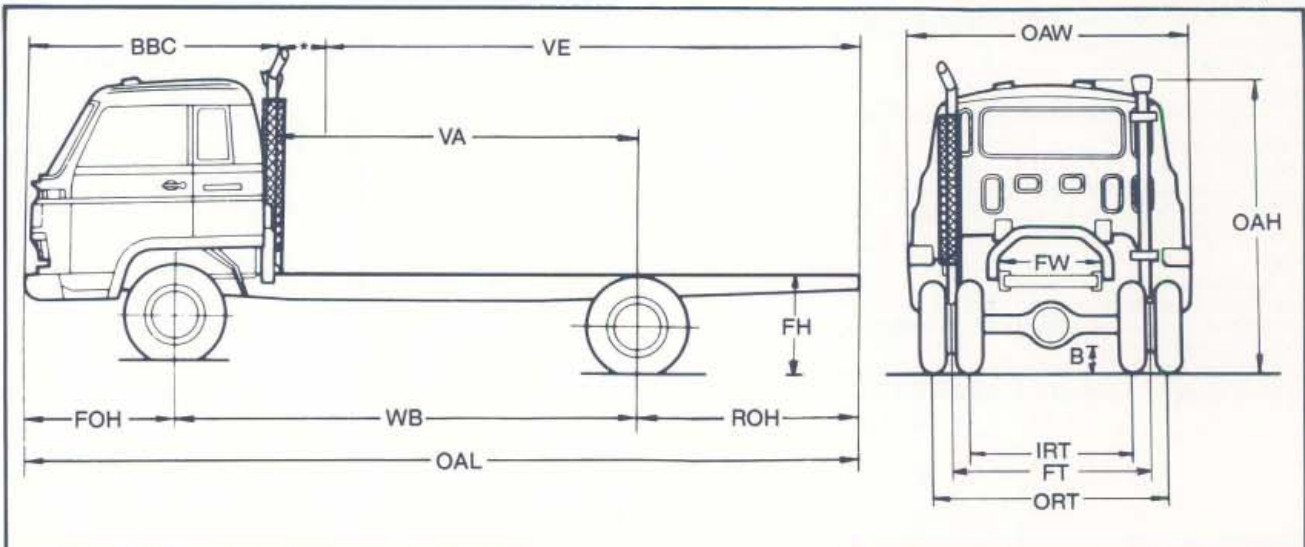

GVM	GCM	Tyres	ESTIMATED KERB WEIGHTS CHASSIS AND CAB (with oil, water and full fuel tank in kg).	Front	Rear	Total
JCR 420S 12,850	18,500	9.00x20-12 ply		JCR 420S 2185	1435	3620
JCR 500S 13,350	18,500	9.00x20-14 ply		JCR 500S 2240	1450	3690