

ISUZU FVZ 1400 FVY 1400



ISUZU
RELIABILITY IS EVERYTHING

AT A GLANCE

GVM	24,000 kg
GCM	36,000 kg
Engine Type	Isuzu SiTEC 275
Displacement	9.8 L
Power	206 kW @ 2,000 rpm
Torque	1,030 Nm @ 1,400 rpm
Wheelbase	4,410 - 6,470 mm

DRIVELINE & CHASSIS SPECIFICATIONS

ENGINE: SITEC 275 (ISUZU 6SD1-TC)

Type: 6 cylinder, 4 stroke, SOHC, direct injection diesel.
Variable Geometry Turbocharger (VGT) and air-to-air intercooler. Adjustable roller type rocker arms.

Displacement: 9,839 cc

Compression Ratio: 16.0:1

Bore x Stroke: 120 x 145 mm

Max power (DIN NET): 206 kW @ 2,000 RPM

Max torque (DIN NET): 1030 Nm @ 1,400 RPM

Emissions Standard: ADR 80/00 (Euro III)

- Plate type oil cooler. 28.4 L oil capacity. Separate full flow main filter and bypass oil filter.

COOLING SYSTEM

- 6 blade, 600 mm diameter cooling fan with thermostatically controlled viscous clutch. Dual drive belts.
- Radiator frontal area: 5,088 cm².
- 29 L coolant capacity.

AIR INTAKE SYSTEM

- Vertical air intake mounted on back of cab. Two stage Donaldson air cleaner with 280 x 380 mm main element and 160 x 350 mm secondary element.
- 610 x 540 mm air-to-air intercooler.

FUEL SYSTEM

- Denso common rail fuel injection. Separate fuel filter and water separator.
- 400 L aluminium tank (Long models).
- 180 L steel tank (FVZ Medium, PTO & Auto models).

ENGINE DRIVEN PTO (FVZ MEDIUM PTO MODEL ONLY)

- Constant mesh flywheel driven. PTO rotates @ 1.1 x engine speed.
- 440 Nm maximum output torque.
- Anti-clockwise rotation when viewed from rear of engine.

CLUTCH

- Air assisted hydraulic control. Single plate 381 mm diameter. Asbestos free cerametallic lining material. Total lining area: 1,363 cm²

TRANSMISSION

EATON RT-7608LL 10 Speed manual (Medium/Long)

- 10 forward speeds. Direct drive.
 - Repeat 'H' shift pattern.
 - 11.1 L oil capacity.
 - SAE PTO opening on RHS and bottom of transmission case.
 - Gear ratios (: 1)
- | | | | | | | | | | |
|---------|-------|-------|------|------|------|------|------|------|------|
| L-Low | Low | 1st | 2nd | 3rd | 4th | 5th | 6th | 7th | 8th |
| 18.81 | 12.31 | 8.24 | 6.07 | 4.51 | 3.32 | 2.48 | 1.83 | 1.36 | 1.00 |
| Reverse | L-Low | Low | High | | | | | | |
| | 17.87 | 11.69 | 3.52 | | | | | | |

ALLISON MD 3560P 6 Speed automatic (Auto models)

- Electronically controlled automatic transmission with adaptive shift. 6 forward speeds including overdrive.
 - 27 L oil capacity.
 - SAE PTO opening on LHS & RHS of transmission bellhousing.
 - Gear ratios (: 1)
- | | | | | | | |
|------|------|------|------|------|------|------|
| 1st | 2nd | 3rd | 4th | 5th | 6th | Rev |
| 4.59 | 2.25 | 1.54 | 1.00 | 0.75 | 0.65 | 5.00 |

Sitec 275

Maximum Power : 206 kW @ 2,000 RPM

Maximum Torque : 1,030 Nm @ 1,400 RPM

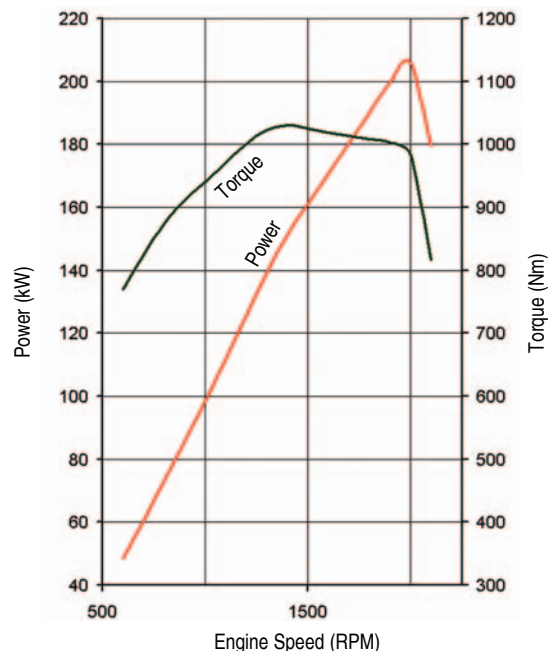

ISUZU SITEC 275 (6SD1-TC) ENGINE PERFORMANCE CHART

AXLES

FRONT: MERITOR FG941

- Reverse Elliot I-beam. 6,600 kg capacity.
- Oil bath lubricated front wheel hubs, see through oil level indicator.

REAR: MERITOR RT-40-145G TANDEM AXLE SET.

- 18,100 kg capacity.
- Drive ratios: Manual: 3.909:1, Auto: 5.857:1
- 1,300 mm tandem axle spacing.
- Air operated inter-axle differential lock.
- Cross locks available as optional fitment.

SUSPENSION

FRONT

- Single stage, alloy steel, taper leaf springs. Fully wrapped eye with greasable shackles.
- Nominal size: 1,600 x 80 mm
- Total spring capacity (at ground): 6,670 kg
- Double acting, hydraulic shock absorbers. Stabiliser bar.

FVZ 1400 REAR

- Alloy steel, multi-leaf springs. Isuzu 6 rod and trunnion location system.
- Nominal size: 1,300 x 90 mm
- Total spring capacity (at ground): 20,740 kg

FVY 1400 REAR

- Hendrickson HAS400 airbag.
- Four rolling lobe air springs.
- Total spring capacity (at ground): 18,140 kg
- Outboard mounted double acting shock absorbers.
- Height control valve.

BRAKES

- Meritor 'Q-Plus' full air 'S-cam' brakes with automatic slack adjusters.
- Front drum diameter: 419 mm
- Rear drum diameter: 419 mm
- Swept area: 12,716 cm²
- Asbestos free lining material.
- Spring type parking brake acting on rear wheels.
- Air controlled exhaust brake.
- 96.9 L total air reservoir capacity.
- Air dryer.

STEERING

- Power assisted recirculating ball steering.
- 22.4:1 gear ratio.
- 5.4 turns lock to lock.
- 45° wheel cut angle (inside wheel).

WHEELS AND TYRES

- 8.25 x 22.5 Ten stud ISO standard disc wheels.
- 295/80R22.5 152/148 Michelin XZE2 steer tyres. Rating: 3,550 kg per tyre.
- 11R22.5 148/145L Michelin XDE2 drive tyres. Rating: 2,900 kg per tyre (dual configuration).
- Frame mounted winch type spare wheel carrier (Except FVZ auto). Spare wheel and XZE2 tyre assembly supplied.

AXLE LOAD SUMMARY

	FRONT	REAR
FVZ 1400		
Axle Capacity (kg):	6,600	18,100
Spring Capacity (kg):	6,670	20,740
Tyre Capacity (kg):	7,100	23,200
Legal Limit (kg):	6,000	16,500
Limit (kg):	6,000	16,500
FVY 1400		
Axle Capacity (kg):	6,600	18,100
Spring Capacity (kg):	6,670	18,140
Tyre Capacity (kg):	7,100	23,200
Legal Limit (kg):	6,000	17,000
Limit (kg):	6,000	17,000

Note: Vehicle loading limit is determined by the combination of axle loading limit, GVM and GCM limit, and government regulatory requirements. Consult your Isuzu dealer to select the correct vehicle for your specific application.

CHASSIS FRAME

- Cold riveted ladder frame with parallel side rails.
- | | FVZ Med./PTO/Auto | FVZ Long/FVY Long/FVY Auto |
|--------------------------|-------------------|----------------------------|
| • Frame material | HT540A | SAPH440 |
| • Side rail (mm): | 254 x 85 x 8 | 258 x 85 x 10 |
| • Rear frame width (mm): | 850 | 850 |
- Frame reinforcement section.
 - Front and rear tow hooks (except FVZ PTO model)

ELECTRICAL SYSTEM

- 24 Volt electrical system, 60 Amp alternator, 5.5 kW starter motor.
- 2 x 75D23R (520CCA) batteries connected in series.

CABIN SPECIFICATIONS AND APPOINTMENTS

CAB EXTERIOR

- All steel cab, side door impact protection beams. Outer body panels galvanised, corrosion resistant primer treated cab.
- Manual cab tilt to 45°. Access to fluid checkpoints without tilting cab. Front access panel for clutch, windscreen washer fluids and cab air filter screen. Four point silicone filled rubber cab mounting.
- Body coloured steel front bumper with step holes and footplate.
- 90° opening internally reinforced door. Heavy duty aluminium non slip entry steps.
- Tinted, laminated windscreen. 2 speed windscreen wiper system, variable intermittent wipe mode, triple washer jets.
- Halogen headlamps. Park lamps and roof-mounted clearance lamps.
- Combination brake, turn, reverse and marker lamps, registration plate illumination lamps. Extended wiring harness. Reverse alarm.
- 'West Coast' type rear view mirrors. Large flat mirror glass with additional, independently adjustable convex 'spot' mirror on both sides.
- Dual tone air horn.

CAB INTERIOR

- Isringhausen ISRI 6500/517 air suspension driver's seat, auto weight adjustment to 130 kg. Height, rake and backrest recline adjustment. Pneumatic lumbar support. Reclining passenger bucket seat. Centre seat with folding seat back (except auto and PTO models).
- 3-point, lap sash seatbelts with emergency locking belt retractors in all outboard seating positions. Centre lap seatbelt (except auto and PTO models).
- 'A' pillar entry assist grips. Fluorescent dome interior lamp with On/Door/Off switch activated by either door.
- Full interior panel trim, padded roof lining, vinyl floor mats. Windscreen header storage shelf. DIN sized aperture in

- dash for CB. Overhead console fitted with harness for CB.
- Tilt/Telescopic adjustable steering column, soft feel urethane steering wheel.
- 12 Volt, 100 Watt and 24 Volt, 2 pin accessory sockets located in centre console.
- Electric windows.
- Central locking with remote keyless entry.
- Centre facia pullout drinks holder. Lockable centre storage compartment. Cigarette lighter.
- Heater/Demister with 4-speed fan and outlets for windscreen, side windows, face and floor.
- Standard fully integrated air conditioning.
- Two speaker Eurovox Radio/CD player with digital anti skip memory.
- Remote seek/volume and mute switch located on dash to right of steering wheel.
- Optional 10 stack CD player.

DRIVER CONTROLS

- Key-operated engine start/stop and steering lock. Electronic throttle control. Engine idle speed control.
- Left side combination stalk: Windscreen wipers, washers, exhaust brake and hazard lights.
- Right side combination stalk: Turn signals and headlamps.
- Pushbutton gear selection (automatic models).

INSTRUMENTATION

- Gauges: Electronically driven speedometer, odometer, tripmeter, tachometer. Gauges for coolant temperature and brake air pressure.
- Warning lamps: Warning bulb check switch. Battery charge, brake system, engine malfunction, oil pressure, stop and tail lamp failure.
- Indicator lamps: Turn signals, parking brake, high beam, exhaust brake engaged.

FVZ 1400 Medium / PTO / Long / Auto
 8FU02-7E0 (MU1) 8FU02-7E2 (MU1) 8FV02-7E0 (MU1) 8FV02-7F0 (MU1)

FVY 1400 Long / Auto
 8FV02-7E1 (MU1) 8FV02-7F1 (MU1)

PERFORMANCE (Calculated)

	FVY 1400 MEDIUM / LONG	FVY 1400 AUTO	FVZ 1400 MEDIUM / PTO
Max Geared speed:	105* km/h @ 2,100 rpm	108* km/h @ 2,100 rpm	105* km/h @ 2,100 rpm
Gradeability (lowest gear):	58% at 23,000 kg GVM	38% at 23,000 kg GVM	59% at 22,500 kg GVM
Gradeability (top gear at 100 km/h):	0.8% (2.5 x 3.4 m van body at 23,000 kg GVM)	1.0% (refuse truck at 23,000 kg GVM)	1.1% (concrete agitator at 22,500 kg GVM)
Engine speed (top gear at 100 km/h):	2,000 rpm	1,950 rpm	2,000 rpm

Performance figures quoted are representative only and based on typical dimensions, body styles and weights. Please consult your Isuzu dealer for an estimation based on your specific application. * Road speed limited to 100 km/h

MODEL RATINGS AND DIMENSIONS

MODELS	RATINGS (kg)		TARE MASS [#] (kg)			DIMENSIONS (mm)											TURN CIRCLE	
	GVM	GCM	TOTAL	FRONT	REAR	WB	OAL	FOH	ROH	CA	CE	RT	ORT	CH	CW	FFH		RFH
FVZ Med./PTO	24,000	36,000	6,575	3,130	3,445	4,410	7,600	1,250	1,940	3,700	5,640	1,855	2,465	2,790	2,440	985	1,060	15.3 m
FVZ Long	24,000	36,000	7,060	3,345	3,715	6,470	11,145	1,250	3,425	5,760	9,185	1,855	2,465	2,785	2,440	985	1,060	21.3 m
FVZ Auto	24,000	36,000	6,645	3,155	3,490	5,300	9,195	1,270	2,625	4,590	7,215	1,855	2,465	2,785	2,440	985	1,060	18.0 m
FVY Long	24,000	36,000	6,855	3,340	3,515	6,470	11,145	1,250	3,425	5,760	9,185	1,840	2,450	2,785	2,440	985	1,020	21.3 m
FVY Auto	24,000	36,000	6,770	3,285	3,485	6,470	11,145	1,250	3,425	5,760	9,185	1,840	2,450	2,785	2,440	985	1,020	21.3 m

[#] Estimated mass of cab/chassis with oil, water and fuel tank containing 10 litres of fuel and excluding spare wheel (95 kg) and tools (30 kg). PTO adds approx. 50 kg to tare mass.

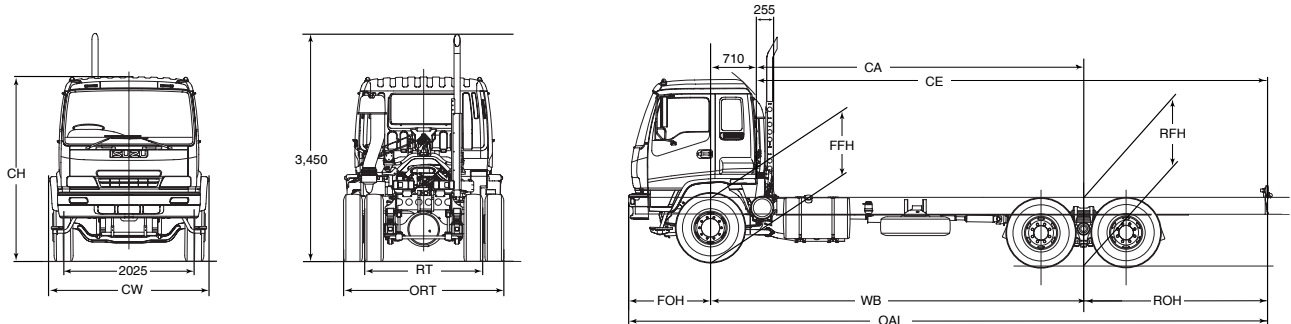

For further information regarding Cab/Chassis dimensions your Isuzu Dealer can access detailed Body Builders diagrams from the Isuzu Truck Technical Reference CD.

ISUZU NEW TRUCK WARRANTIES

STANDARD TRUCKPOWER WARRANTY*			TRUCKPOWER EXTENDED WARRANTY OPTIONS [#]		
NEW VEHICLE	3 years	200,000 km	4 years / 300,000 km	5 years / 350,000 km	6 years / 400,000 km
DRIVETRAIN	3 years	200,000 km			
CAB CORROSION	3 years	unlimited			

Why have Isuzu Trucks been Australia's No. 1 choice since 1989? *

- Widest range of models to suit most applications
- Premium componentry and Isuzu diesel engines
- Network of over 40 specialist Isuzu Dealerships and branches
- Sales, services and parts support
- Predictable operating costs through Dealer ISIS program
- Factory and range of extended warranties available
- High resale values
- Leading reputation for reliability

www.isuzu.com.au

* Source Truck Tracker 2003

* Subject to the conditions outlined in the I-GM New Vehicle Warranty, the Isuzu FVZ & FVY models carry a standard factory warranty which covers the owner:

- (i) for the entire vehicle, for the first 36 months or 200,000 km (whichever comes first).
- (ii) for the drivetrain, which runs concurrently, for 36 months or 200,000 km (whichever comes first).
- (iii) against cab corrosion, for 36 months and unlimited kilometres.

[#] A TruckPower Extended Warranty as illustrated is available by purchase to cover the owner against the failure of original components, but excludes some components and expendable items such as oil, filters, etc. Please consult with your Isuzu Dealer for full details obtained from a dedicated brochure available to customers.

ISUZU-GENERAL MOTORS AUSTRALIA LTD A.C.N. 006 962 572. PLEASE NOTE: as the policy of I-GM is one of continual product improvement, all specifications and equipment are subject to change without notice. No I-GM dealer or other person is authorised or permitted to give or make any statement, assertion or undertaking in relation to the quality, performance, characteristics, descriptions or fitness for any purpose of any I-GM product or in connection with the supply of any I-GM product which is at variance with any written statement, assertion or undertaking on any of these subjects given or made by I-GM in its published sales literature, and the company accepts no liability for any such unauthorised action. I-GM has franchised dealers in many parts of Australia, for the sale of service, parts and the provision of service to the owners of I-GM products. Every endeavour is made to ensure that such dealers carry adequate stocks of service parts and are equipped to provide satisfactory service, but makes no promise, other than that contained in the I-GM new vehicle warranty, that such parts or service facilities will be available or available at any specific location or at any particular time. A word about this specification sheet. We have tried to make it as comprehensive and factual as possible. However, since the time of printing some of the information you will find here may have been updated. Also, some of the equipment shown or described through this specification sheet may have been changed and/or is available at extra cost. And the right is reserved to make changes at any time without notice, in prices, colours, materials, equipment and models. Your I-GM dealer has details and before ordering, you should ask him/her to bring you up to date.

OCTOBER 2004. ARK/GM 0133

ISUZU
 RELIABILITY IS EVERYTHING