

# ISUZU FRR550 S

## LONG

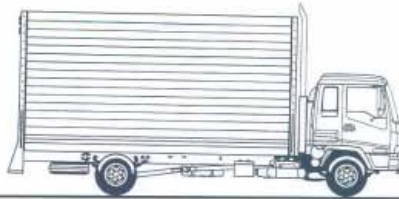

### ENGINE ISUZU 6HH1-S

Type:	6 cylinder, overhead camshaft, 4 stroke, direct injection, diesel.
Bore x Stroke:	115 mm x 132 mm.
Displacement:	8226 cc.
Compression Ratio:	18.5 : 1.
Output - Power:	150 kW @ 2850 RPM. (ISO 1585)
Torque:	539 Nm @ 1700 RPM. (ISO 1585)

### COOLING SYSTEM

- 6 blade plastic cooling fan 500 mm diameter with thermatic fan clutch.
- Corrugated fin radiator with fan shroud. Frontal area 3820 cm<sup>2</sup>. Coolant capacity 23.3 litres.

### CLUTCH

- Hydraulic control dry single plate. 355 mm (14") diameter.
- Asbestos free lining material. Total lining area (both sides) 1164 cm<sup>2</sup>.

### TRANSMISSION: ISUZU MBJ6T

- 6 speed overdrive, constant mesh with synchromesh on gears 2-6. Oil capacity 5.3 litres.
  - Gear ratios (: 1)
- |       |       |       |       |       |       |       |
|-------|-------|-------|-------|-------|-------|-------|
| 1st   | 2nd   | 3rd   | 4th   | 5th   | 6th   | Rev   |
| 6.378 | 3.627 | 2.307 | 1.452 | 1.000 | 0.787 | 6.595 |
- Maximum geared speed 121 km/h
  - 2 piece propeller shaft, 90 mm diameter.

### REAR AXLE: ISUZU R077 CAPACITY 7700 KG

- Banjo type, fully floating, single reduction. Ratio 4.75 : 1.
- Hypoid type ring gear. 343 mm diameter. Oil capacity 5.5 litres.

### FRONT AXLE: ISUZU F036 CAPACITY 3600 KG

- Reverse Elliot I-beam type. King pin diameter 35 mm with cylindrical roller thrust bearing.

### BRAKES

- Air over hydraulic, dual circuit, front two leading, rear dual two leading.
- Drum diameter front and rear 320 mm. Total swept area 5127 cm<sup>2</sup>.
- Air dryer.
- Asbestos free lining material.
- Spring park brake acting on rear wheels.

### AIR INTAKE SYSTEM

Donaldson 11" two stage with vertical air intake stack and rain head.

### ELECTRICAL SYSTEM

- Batteries - 2 x 12 volt / 65 amp/h, negative earth.
- Alternator - 24 volt / 40 amp.
- Starter motor - 24 volt / 4.5 kW.
- Rear stop and tail lamps and licence plate lamp with long leads for variable body mounting.

### EXHAUST SYSTEM

- Horizontal exhaust muffler with vertical exhaust stack.
- Exhaust brake, air controlled.

### FUEL SYSTEM

- In line plunger, Bosch 'ADS' type fuel injection pump with mechanical all speed governor. In line filter, see through water separator with drain cock. Single fuel tank, capacity 180 litres.

### STEERING

- Fully integral, power assisted, recirculating ball type.
- Gear ratio 16.1 ~ 18.8 : 1. Turns lock to lock 4.1.
- Gear driven vane type oil pump. Oil capacity 1.5 litres.

### SUSPENSION

#### FRONT

- Semi-elliptical, alloy steel tapered multi-leaf springs. Fully wrapped eye with greaseable shackles.
- Length x Width x Thickness x No. leaves  
1200 mm x 70 mm x 10 mm x 8
- Hydraulic, double acting, telescopic shock absorbers.

#### REAR

- Semi-elliptical, alloy steel tapered multi-leaf springs. Fully wrapped eye with greaseable shackles.
- Length x Width x Thickness x No. leaves  
Main: 1300 mm x 70 mm x 11 mm x 8  
Aux: 850 mm x 70 mm x 10 mm x 3  
850 mm x 70 mm x 11 mm x 4

### WHEELS AND TYRES

#### WHEELS

- 6.00 x 17.5, 6 stud disc wheels, 225/90R17.5 - 14 ply tubeless tyres front and rear.

#### TYRES

- Number of wheels and tyres 7, including spare. Winch type spare wheel carrier.

### CHASSIS FRAME

- Parallel rail, ladder type channel section, cold riveted.
- Straight frame for easy body mounting. Frame width 840 mm.
- Side member dimensions: 225 mm x 70 mm x 6 mm.
- Frame reinforcement angle section 203 mm x 64 mm x 4.5 mm at back of cab.
- Material, HT540A high tensile, weldable steel

## LUBRICATION SYSTEM

- Pressure feed lubrication with combination full flow and partial flow by-pass filter. Plate type oil cooler in water jacket. Oil capacity 13.5 litres including filter.

## CAB EXTERIOR

- All steel cab with welded strengthening ribs and side door impact beams. Torsion bar assisted manual tilt to 45°.
- 4 silicon filled rubber cab isolators.
- Cation electrodeposition primer.
- Bumper bar with step holes and footplate.
- Halogen headlamps, hinged for easy bulb replacement. Park lamps and cab clearance lamps.
- Turn signal lamps in front bumper and doors.
- 2 speed wiper/washer with variable intermittent mode. Triple washer jets mounted on wiper arms.
- Tinted, laminated windscreen; tinted, toughened side and rear glass.
- West Coast type rear view mirrors.
- Alloy non-slip cab entry steps.
- Lift up front access panel for clutch and windscreen washer fluids, cab air filter screen. Engine and brake fluid check points at rear of cab.

## CAB INTERIOR

- Fully trimmed cab interior with cloth seat facings, formed roof lining. Overhead storage lockers. Driver and passenger sun visors.
- Pull out drinks holder in centre fascia, cigarette lighter with ash trays in doors.
- Driver's seat with mechanical suspension and 3 way lumbar support. Adjustment for seat back recline, seat slide and weight control.
- Outboard reclining passenger seat with under-seat storage drawer. Folding centre seat back with lockable compartment and tray.
- Outboard lap/sash seat belts with emergency locking retractors, centre lap seat belt.
- Tilt/telescopic adjustable steering column, soft feel urethane steering wheel.
- Easy entry grab handles on 'A' pillars.
- Heater demister with 4 speed fan, 4 outlet vents to screen, 5 fascia outlets, 5 foot outlets, demister ducts to door glass.
- AM/FM radio cassette with digital clock, dash mounted.
- DIN standard aperture in dash for CB radio.
- Park brake activation lever at left side of driver's seat.
- Rear vision mirror.
- Passenger side assist grip.
- Driver's left foot rest.
- Cab exhaust vents rear/upper cab.
- Business card clip. Coat hook at rear of cab.
- Elastic mesh pocket on driver's door.

## CONTROLS

- Left side combination stalk switch for exhaust brake, windscreen wipers and washer; hazard lamps.

- Right side combination stalk switch for headlamps, high beam and turn signals.
- Engine idle speed adjust control.
- Key operation for engine start and stop, external engine crank switch for service when cab is tilted.
- 3 way switch for interior lamp activated by driver and passenger doors.
- 24 volt-2 pin accessory plug in centre console.

## INSTRUMENTATION

- Gauges: Speedometer, odometer, trip meter and tachometer. Gauges for coolant temperature, fuel level and brake air pressure.
- WARNING LAMPS: With warning bulb check switch. Battery charge, oil pressure, low air pressure, brake system, stop and tail light failure.
- INDICATOR LAMPS: Turn signals, parking brake on, high beam on, exhaust brake engaged. Reversing lamp and beeper.

## TOOLS

- Lockable tool box with 7000 kg capacity jack and wheel changing tools, tool kit.

## MODEL, CODES & RATINGS

MODEL	WHEELBASE	GVM	GCM	ORDERING CODE
FRR 550 S LONG	4850mm	10400kg	16000kg	8FF02-271

## KERB MASS\* (kg)

	Front	Rear	Total
FRR 550 S LONG	2,140	1,040	3,180

\*Estimated mass of chassis cab with oil, water and fuel tank containing 10 litres of fuel. Excluding spare wheel and tools.

## DIMENSIONS (mm)

	FRR 550 S LONG
WB Wheelbase	4,850
OAL Overall Length	8,170
ROH Rear Overhang	2,135
CA Cab To Axle	4,055
CE Cab To End Of Frame	6,190
FFH Front Frame Height, Unladen	790
FFH Front Frame Height, Laden	761
RFH Rear Frame Height, Unladen	900
RFH Rear Frame Height, Laden	835
Turning Circle (Kerb To Kerb)	14.9m
Nominal Max. Body Length*	6,560

\*Except Turning Circle: metres. \*Subject to weight distribution

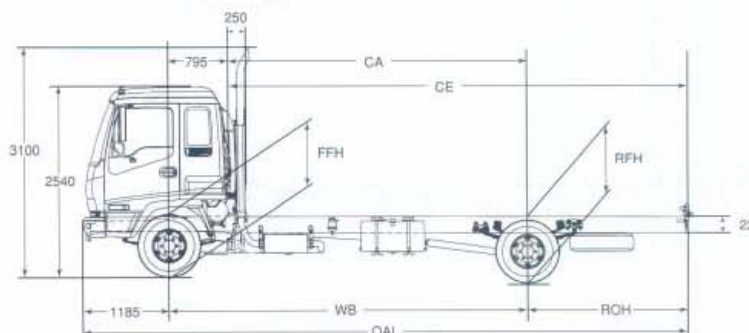
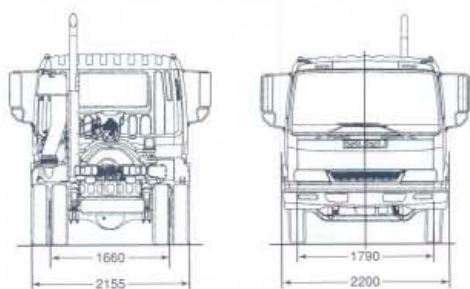

# FRR550 S LONG

# ISUZU

RELIABILITY IS EVERYTHING