

FVZ 1400

FVY 1400



FVZ 1400 pictured

AUSTRALIA'S TOP SELLING TRUCK BRAND SINCE 1989. Truck tracker 2008.

AT A GLANCE

GVM	24,000 kg
GCM	36,000 kg
Power	221 kW @ 2,400 rpm
Torque	981 Nm @ 1,450 rpm

ADVANCED TECHNOLOGY

- Emissions: Euro IV - exceeds ADR80/02
- Driver airbag with seatbelt pretensioner
- ADR 42 compliant sleeper with mattress
- ECE-R29 compliant cab
- ECE-R93 compliant Front Underun Protection Device (FUPD)
- Anti-lock Braking System (ABS)
- Hill Start Aid (HSA) - except auto model
- Electric mirrors
- Electro-hydraulic cab tilt
- Coil spring cab suspension
- Front stabiliser bar
- Cruise control (except auto model)
- Isri 6860 seat with integrated seatbelt

Driveline & Chassis Specifications

ENGINE: SiTEC SERIES II 295 (ISUZU 6HK1-TCS)

- Type:** 6 cylinder 24 valve SOHC
- Displacement:** 7,790 cc
- Compression Ratio:** 17.5:1
- Bore x Stroke:** 115 x 125 mm
- Max power (DIN-NET):** 221 kW (296 HP) @ 2,400 RPM
(JIS Gross): 228 kW (306 HP) @ 2,400 RPM
- Max torque (DIN-NET):** 981 Nm (724 lb.ft) @ 1,450 RPM
(JIS Gross): 1,014 Nm (748 lb.ft) @ 1,450 RPM
- Induction system:** Electronically controlled variable nozzle turbocharger with air-to-air intercooler.
- Fuel injection:** Direct injection high pressure common rail system.
- Emission control system:** Two-stage electronically cooled EGR with exhaust Diesel Particulate Diffuser (DPD). ADR 80/02 (Euro IV) compliant.

CLUTCH (manual transmission model)

- Air assisted hydraulic control. Single plate 381 mm diameter.
- Total lining area: 1,363 cm²

TRANSMISSION

ZF 9 S 1110 TO

- 9 speed with air assisted shift.
- Synchromesh on gears 1-8. Repeat 'H' shift pattern.
- PTO provision at rear of transmission case.
- Gear ratios (:1) Crawler: 9.48

1st	2nd	3rd	4th	5th	6th	7th	8th	Rev
6.58	4.68	3.48	2.62	1.89	1.35	1.00	0.75	8.97

ALLISON 3500 SERIES (auto model)

- 6 speed automatic. 4th generation electronic controls with adaptive shift.
- LHS and top PTO openings on transmission bellhousing. Engine driven PTO drive gear.
- Gear ratios (:1)

1st	2nd	3rd	4th	5th	6th	Rev
4.59	2.25	1.54	1.00	0.75	0.65	5.00

AXLES

Front: MERITOR

- FG941 reverse Elliot I-beam. 6,600 kg capacity.

Rear: MERITOR

- RT-40-145G tandem axle set. 18,100 kg capacity.
- Driver controlled inter-axle lock.
- Drive ratio: 6.14:1 (manual model), 6.43:1 (auto model)

SUSPENSION

Front:

- Single stage alloy steel taper leaf springs.
- Double acting hydraulic shock absorbers. Stabiliser bar.

Rear (FVZ 1400):

- Multi leaf springs with Isuzu 6 rod and trunnion location system.

Rear (FVY 1400):

- Hendrickson HAS400 airbag. 18,100 kg capacity at ground.
- Outboard mounted double acting shock absorbers.

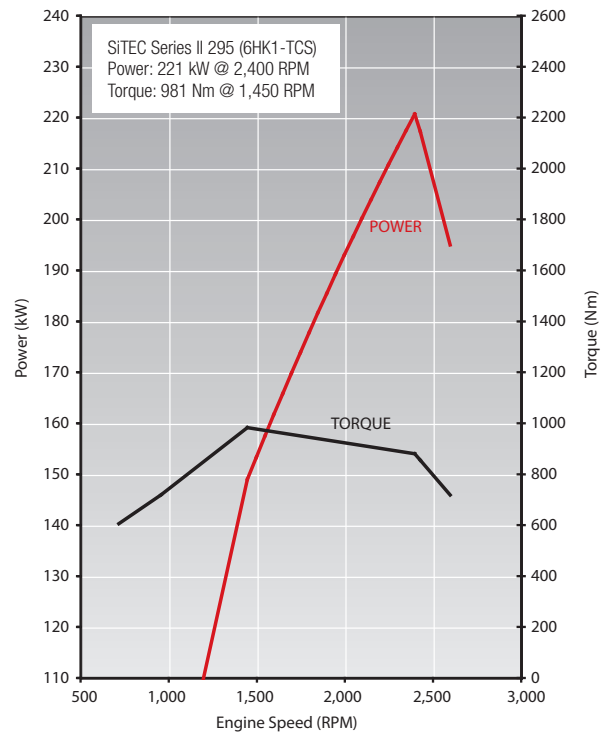

BRAKES

- Meritor 'Q-Plus' dual circuit full air 'S-cam' front and rear drum brakes with auto slack adjusters.
- ABS.
- Hill Start Aid (HSA) - except auto models.
- Front drum size: 419 x 127 mm
- Rear drum size: 419 x 178 mm
- Spring park brake acting on all rear wheels.
- Air controlled exhaust brake.
- Air dryer.

STEERING

- Power assisted recirculating ball steering.
- Gear ratio: 22.4:1
- Turns lock to lock: 5.4
- Maximum angle: 45° (inside wheel) / 35° (outside wheel)

WHEELS AND TYRES

- 22.5 x 8.25 ten stud ISO standard steel wheels.
- **Steer axle:** 295/80R22.5 152/148M Michelin XZE2 Tubeless.
- **Drive axle:** 11R22.5 148/145L Michelin XDE2 Tubeless.
- Maximum tyre rating:
 - Steer axle: 7,100 kg
 - Tandem drive axle set: 23,200 kg
- Spare wheel and XZE2 tyre assembly. Winch type carrier (except FVZ medium).

CHASSIS FRAME

- Cold rivetted ladder frame with parallel side rails.
- Frame sidemember material:
 FVZ medium/auto: HT540A
 FVZ/FVY long: SAPH440
- Frame dimensions:
 FVZ medium/auto:
 Side rail (mm): 254 x 85 x 8.0
 Rear frame width (mm): 850
 FVZ/FVY long:
 Side rail (mm): 258 x 85 x 10
 Rear frame width (mm): 850

FUEL TANK

- Frame mounted fuel tank. 200L steel (FVZ/FVY auto), 400L aluminium (except FVZ/FVY auto).
- Lockable fuel cap.

ELECTRICAL SYSTEM

- 24 volt electrical system.
- **Manual model:** 60 amp alternator. **Auto model:** 90 amp alternator.
- 24 Volt, 4.5 kW starter motor.
- 2 x 80D26L (630 CCA) batteries connected in series.

Cabin Specifications and Appointments

CAB EXTERIOR

- All steel construction with electro-hydraulic cab tilt. High tensile steel used for cab underframe.
- Complies with ECE-R29 cab strength standard.
- Full floating cab with coil spring suspension and hydraulic shock absorbers.
- Heavy duty non slip entry steps.
- 90° opening internally reinforced front doors.
- Water spray suppression guards and front mudflaps.
- Laminated windscreen with shade band.
- Two speed windscreen wipers, with intermittent wipe mode.
- Halogen multi-reflector headlamps incorporating turn signals and front foglamps. Additional door mounted side indicator lamps.
- Combination brake, turn, reverse and marker lamps, registration plate illumination lamps. Extended wiring harness. Reverse alarm.
- Roof-mounted clearance lamps.
- Heated and powered exterior main mirrors with flat glass and additional powered convex "spot" mirrors.
- Body coloured grille.
- Body coloured steel air dam bumper.
- FUPD underun bar - complies with ECE-R93.

CAB INTERIOR

- Isri 6860 air suspension driver's seat with pneumatic lumbar support, height, rake and automatic weight adjustment.
- Front passenger adjustable bucket seat and front centre seat with folding seat back.
- 3-point lap sash seatbelts in all outboard seating positions. Driver seatbelt with pretensioner integrated with driver seat. Centre seat lap belts.
- ADR 42 compliant sleeper with mattress.
- Driver airbag.
- Door and roof pillar entry assist grips.
- Full interior trim, padded roof lining and vinyl floor covering. Driver and passenger windscreen header storage shelf.
- Tilt/Telescopic adjustable steering column, soft feel urethane steering wheel.
- Electric windows.
- Central locking with remote keyless entry and immobiliser.
- Twin cup holders. 24V cigarette lighter. Dashboard hook.
- Front door mounted storage pockets and driver's side ashtray.
- Centre console box with storage tray. Fold down storage tray behind centre

seat backrest.

- Front passenger glovebox.
- Fully integrated auto control air conditioning and heater/demister with 4-speed fan and outlets for windscreen, side windows, face and floor.
- Fluorescent type interior lamp with On/Door/Off switch.
- 2 DIN, two speaker radio/CD multimedia unit with 4.8" LCD touch screen and Bluetooth. Provision for SD card, USB and 3.5 mm plug inputs.
- DIN sized compartment for storage or for CB radio installation.

DRIVER CONTROLS

- Key-operated engine start/stop and steering lock. Engine idle speed control.
- HSA slow/fast engagement control and on/off switch (except auto model).
- DPD regeneration.
- Pushbutton gear selection control (auto model).
- **Left side combination stalk:** Windscreen wipers, washers and exhaust brake.
- **Right side combination stalk:** Turn signals, headlamps and cruise control (except auto model).

INSTRUMENTATION

- Electronically driven speedometer and tachometer. Digital odometer with integrated dual tripmeter. Engine coolant temperature, fuel level and air pressure gauges.
- **Warning lamps:** Check engine, oil pressure, ABS, SRS airbag, alternator charge, service brakes, park brake, seatbelt unfastened, low air pressure, low fuel level, cab lock.
- **Indicator lamps:** HSA (except auto model), warm up system, high beam, DPD status, exhaust brake, turn signals, inter-axle lock, cruise control (except auto model).
- Multi-information display. Shows service interval, instantaneous and average fuel consumption, DPD bar chart, hourmeter, voltmeter, time/day/date and includes 40-120 km/h adjustable vehicle speed warning.

OPTIONS AND GENUINE ACCESSORIES

Include the following (extra cost, request a brochure and further details from your Isuzu dealer):

- Satellite navigation - integrates with multimedia unit and includes NAVTEQ mapping.
- Up to three audio/visual reversing cameras - integrates with multimedia unit.
- Airbag compatible bullbar.
- Air deflector.
- Rear axle cross lock (can be fitted to either or both carriers).

Weights (kg)

Models	Ratings*		Loading Limit* (at ground)		Cab Chassis Mass#		
	GVM	GCM	Front	Rear	Front	Rear	Total
FVZ 1400 Medium	24,000	36,000	6,600	18,100	3,290	3,395	6,685
FVZ 1400 Medium Auto	24,000	36,000	6,600	18,100	3,370	3,405	6,775
FVZ 1400 Auto	24,000	36,000	6,600	18,100	3,475	3,440	6,915
FVZ 1400 Long	24,000	36,000	6,600	18,100	3,545	3,640	7,185
FVY 1400 Long	24,000	36,000	6,600	18,100	3,545	3,440	6,985
FVY 1400 Long Auto	24,000	36,000	6,600	18,100	3,595	3,420	7,015

* Vehicle ratings and front/rear weight limits are subject to government regulatory requirements and weight distribution analysis. Consult your Isuzu dealer to select the correct vehicle for your specific application.
Cab chassis only as supplied and including 10 litres of fuel.

Dimensions (mm)

Models	WB	OAL	FOH	ROH	EA	CE	RT	ORT	CH	FFA (unladen)	RFA (unladen)	RFH (unladen)	Turn Circle (m)
													KERB TO KERB
FVZ 1400 Medium / Medium Auto	4,410	7,605	1,440	1,755	3,710	5,540	1,840	2,445	2,810	1,000	1,075	1,090	15.4
FVZ 1400 Auto	5,300	9,180	1,440	2,440	4,600	7,115	1,840	2,445	2,810	1,000	1,075	1,080	18.5
FVZ 1400 Long	6,470	11,150	1,440	3,240	5,770	9,085	1,840	2,445	2,810	1,000	1,065	1,095	22.6
FVY 1400 Long	6,470	11,150	1,440	3,240	5,770	9,085	1,840	2,445	2,810	1,000	1,020	1,025	22.6
FVY 1400 Long Auto	6,470	11,150	1,440	3,240	5,770	9,085	1,840	2,445	2,810	1,000	1,020	1,025	22.6

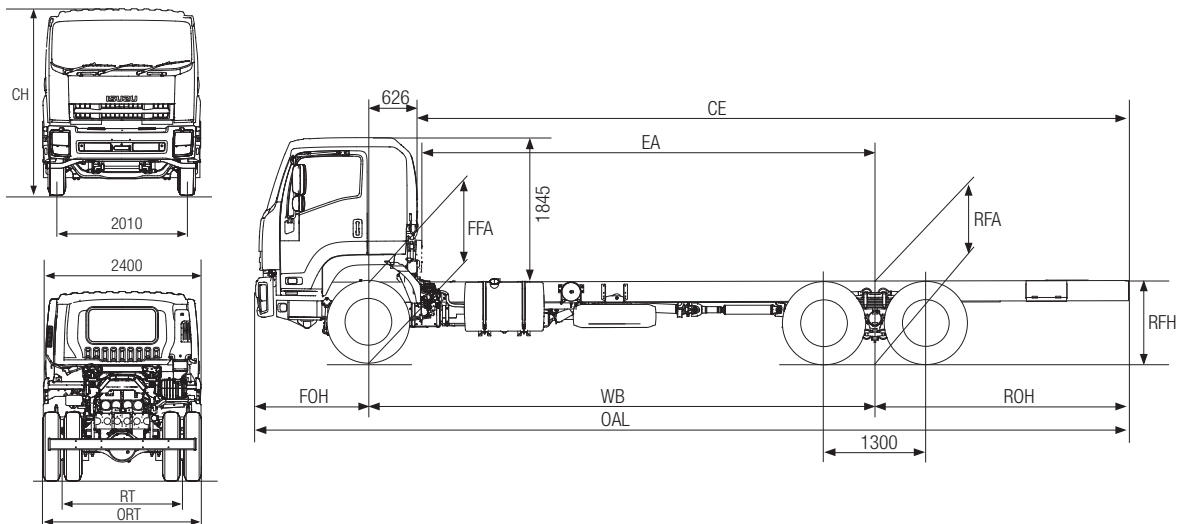

Performance (calculated - typical paved road)

		Geared Speed* (top gear at peak power engine RPM)	Low Speed Gradeability (lowest forward gear assuming no wheel slip)	Engine Speed (top gear at 100 km/h)
FVZ / FVY 1400	At 24,000 kg GVM	101 km/h @ 2,400 RPM	41%	2,380 RPM
FVZ / FVY 1400 Auto	At 24,000 kg GVM	111 km/h @ 2,400 RPM	38%	2,160 RPM

* Maximum speed achievable depends on vehicle frontal area as well as other factors. Consult your Isuzu dealer for more detailed information. Vehicle is speed limited to 100km/h.

Isuzu Warranties

STANDARD ¹		
New Vehicle	3 years 200,000 km 3,000 hrs	
Cab Perforation Corrosion	3 years Unlimited km	
EXTENDED ²		
4 years 300,000 km	5 years 350,000 km	6 years 400,000 km

¹ Subject to the conditions outlined in the IAL New Vehicle Warranty, the Isuzu FVZ and FVY models carry a standard factory warranty which covers the owner: (i) for the entire vehicle, for the first 36 months or 200,000 km or 3,000 hrs (whichever comes first). (ii) against cab perforation corrosion, for 36 months and unlimited kilometres. ² Extended Warranty as illustrated is available by purchase to cover the owner against the failure of original components, but may exclude some components and expendable items such as oil, filters, etc. Please consult with your Isuzu Dealer for full details obtained from a dedicated brochure available to customers.

ISUZU AUSTRALIA LIMITED ABN 97 006 962 572 ("IAL"). The information in this brochure was correct at time of printing, but all measurements, specifications and equipment are subject to change without notice. Some equipment may have been changed and/or is available at extra cost. IAL may make changes at any time without notice, in prices, colours, materials, equipment and models. IAL makes all reasonable attempts to ensure the availability of all vehicles and equipment. The information in this brochure is general in nature. Your Isuzu dealer can confirm all measurements, specifications and vehicle / equipment availability upon request.

December 2009. ARK0472