

# FVR900

Cab/Chassis specification as at September 2000.

## MODEL RATINGS AND DIMENSIONS

MODELS	ENGINE	RATINGS (kg)		TARE MASS* (kg)			DIMENSIONS (mm)										TURNING CIRCLE
		GVM	GCM	TOTAL	FRONT	REAR	WB	OAL	FOH	ROH	CA	CE	FFH UNLADEN	FFH LADEN	RFH UNLADEN	RFH LADEN	
FVR 900 LONG	SITEC200	16,000	24,000	4,890	2,800	2,090	6,050	10,020	1,270	2,700	5,340	8,040	990	941	1,050	951	20.1m

\*Estimated mass of cab/chassis with oil, water and fuel tank containing 10 litres of fuel and excluding spare wheel (95kg) and tools (30kg).

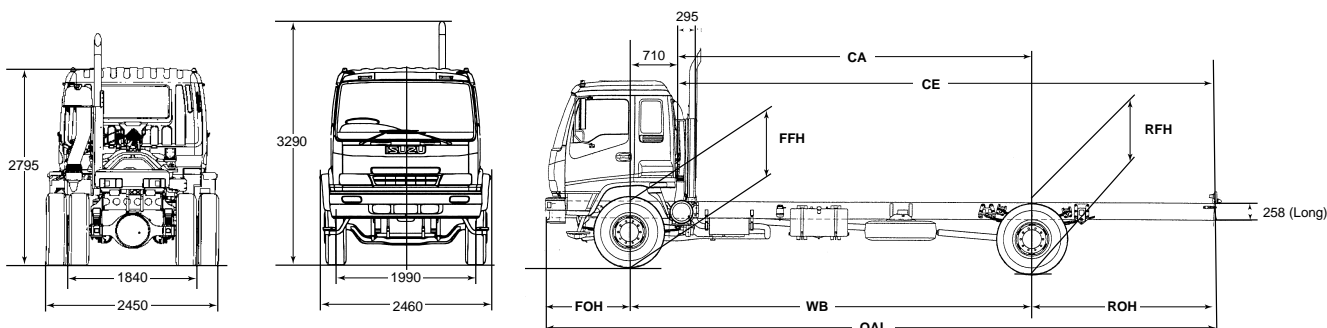

For further information regarding Cab/Chassis dimensions your Isuzu Dealer can access detailed Body Builders diagrams from the Isuzu Truck Data Manual.

## DRIVELINE SPECIFICATIONS

### ENGINE: ISUZU SITEC 200

Isuzu 6HH1-S 6 cylinder, overhead camshaft, four stroke, direct injection, diesel.

**BORE X STROKE:** 115 mm x 132 mm.

**DISPLACEMENT:** 8,226 cc.

**COMPRESSION RATIO:** 18.5 : 1.

**POWER:** 150 kW @ 2,850 RPM. (ISO 1585)

**TORQUE:** 539 Nm @ 1,700RPM. (ISO 1585)

### COOLING SYSTEM

- 6 blade plastic cooling fan 500mm diameter with thermatic fan clutch. Corrugated fin radiator with fan shroud. Frontal area 3,820 cm<sup>2</sup>. Coolant capacity 23.3 litres.

### AIR INTAKE SYSTEM

- Donaldson 11" two stage with vertical air intake stack and rain head.

### EXHAUST SYSTEM

- Horizontal exhaust muffler with vertical exhaust stack.
- Exhaust brake, air controlled.

### FUEL SYSTEM

- In line plunger, Bosch 'ADS' type fuel injection pump with mechanical all speed governor. In line filter, see through water separator with drain cock.
- Single fuel tank, capacity 180 litres.

### CLUTCH

- Hydraulic control dry single plate. 355 mm (14") diameter.
- Asbestos free lining material. Total lining area (both sides) 1,164 cm<sup>2</sup>.

### TRANSMISSION

#### ISUZU MLD7Q 7 speed overdrive

- Constant mesh with synchromesh on gears 2-7. Oil capacity 8.3 litres.
  - Gear ratios to (: 1)
- |       |       |       |       |       |       |       |       |
|-------|-------|-------|-------|-------|-------|-------|-------|
| 1st   | 2nd   | 3rd   | 4th   | 5th   | 6th   | 7th   | Rev   |
| 7.166 | 4.526 | 2.919 | 1.954 | 1.254 | 1.000 | 0.756 | 7.276 |
- Maximum geared speed 109 km/h.
  - Electronically road speed limited to 100 km/h.

### FRONT AXLE

MERITOR FG941 CAPACITY 6,600KG

- Reverse Elliot I-beam type.
- 45° maximum wheel cut angle.
- Oil bath lubricated front wheel hubs with see-through oil level indicator.

### REAR AXLE

MERITOR RS-23-161G CAPACITY 10,400KG

- Banjo type, fully floating, single reduction.
- Rear Axle Ratio: 6.833: 1
- Hypoid type ring gear, 457 mm diameter. Oil capacity 15.0 litres.

**ISUZU**  
RELIABILITY IS EVERYTHING

ISUZU-GENERAL MOTORS AUSTRALIA LTD A.C.N. 006 962 572. PLEASE NOTE: as the policy of I-GM is one of continual product improvement, all specifications and equipment are subject to change without notice. No I-GM dealer or other person is authorised or permitted to give or make any statement, assertion or undertaking in relation to the quality, performance, characteristics, descriptions or fitness for any purpose of any I-GM product or in connection with the supply of any I-GM product which is at variance with any written statement, assertion or undertaking on any of these subjects given or made by I-GM in its published sales literature, and the company accepts no liability for any such unauthorised action. I-GM has franchised dealers in many parts of Australia, for the sale of service, parts and the provision of service to the owners of I-GM products. Every endeavour is made to ensure that such dealers carry adequate stocks of service parts and are equipped to provide satisfactory service, but makes no promise, other than that contained in the I-GM new vehicle warranty, that such parts or service facilities will be available or available at any specific location or at any particular time. A word about this specification sheet. We have tried to make it as comprehensive and factual as possible. However, since the time of printing some of the information you will find here may have been updated. Also, some of the equipment shown or described through this specification sheet may have been changed and/or is available at extra cost. And the right is reserved to make changes at any time without notice, in prices, colours, materials, equipment and models. Your I-GM dealer has details and before ordering, you should ask him/her to bring you up to date.

## CABIN SPECIFICATIONS AND APPOINTMENTS

### CAB EXTERIOR

- All steel cab with welded strengthening ribs and side door impact beams. Torsion bar assisted manual tilt to 45°.
- 4 silicon filled rubber cab isolators.
- Cation electrodeposition primer.
- Bumper bar with step holes and footplate.
- Halogen headlamps, hinged for easy bulb replacement.  
Park lamps and cab clearance lamps.
- Turn signal lamps in front bumper and over wheel arches.
- 2 speed wiper/washer with variable intermittent mode.  
Triple washer jets mounted on wiper arms.
- Tinted, laminated windscreen; tinted, toughened side and rear glass.
- West Coast type rear view mirrors. Additional separately adjusted spotter mirror on each side.
- Alloy non-slip cab entry steps.
- Lift up front access panel for clutch and windscreen washer fluids, cab air filter screen. Engine fluid check points at rear of cab.

### CAB INTERIOR

- Fully trimmed cab interior with cloth seat facings, formed roof lining. Overhead storage lockers. Driver and passenger sun visors.
- Centre storage compartment with lockable lid/tray.
- Pull out drinks holder in centre fascia, cigarette lighter with ash trays in doors.

- Isringhausen ISRI 6500/517 air suspension driver's seat with auto weight adjustment to 130kg. Height, rake and back rest recline adjustment. Pneumatic lumbar support.
- Outboard reclining passenger seat.
- Lap/sash seat belts with emergency locking retractors.
- Tilt/telescopic adjustable steering column, soft feel urethane steering wheel.
- Easy entry grab handles on 'A' and 'B' pillars.
- Heater demister with 4 speed fan, 4 outlet vents to screen, 5 fascia outlets, 5 foot outlets, demister ducts to door glass.
- Optional integrated air conditioning.
- Eurovox AM/FM radio cassette with digital clock, dash mounted. Remote seek/volume and mute switch located on dash to right of steering wheel.
- Optional 6-stack CD player.
- DIN standard aperture in dash for CB radio.
- 12 Volt /100W cigarette lighter type electrical socket located in centre console.
- 24 Volt – 2 pin accessory plug in centre console.
- Park brake activation lever at left side of driver's seat.
- Rear vision mirror.
- Passenger side assist grip.
- Driver's left foot rest.
- Cab exhaust vents rear/upper cab.
- Business card clip. Coat hook at rear of cab.
- Elastic mesh pocket on driver's door.

### CONTROLS

- Left side combination stalk switch for exhaust brake, windscreen wipers and washer, hazard lamps.
- Right side combination stalk switch for headlamps, high beam and turn signals.
- Engine idle speed adjust control.
- Key operation for engine start and stop, external engine crank switch for service when cab is tilted.
- 3 way switch for interior lamp activated by driver's door.

### INSTRUMENTATION

- GAUGES: Speedometer, odometer, trip meter and tachometer. Gauges for coolant temperature, fuel level and brake air pressure.
- WARNING LAMPS: With warning bulb check switch. Battery charge, oil pressure, low air pressure, brake system, stop and tail light failure.
- INDICATOR LAMPS: Turn signals, parking brake on, high beam on, exhaust brake engaged. Reversing lamp and beeper.

### TOOLS

- Lockable tool box. 10,000kg capacity jack and wheel changing tools, tool kit.

## CHASSIS SPECIFICATIONS

### CHASSIS FRAME

- Parallel rail, ladder type channel section, cold rivetted.
- Straight frame for easy body mounting. Frame width 850 mm.
- Side member dimensions: 258mm x 85mm x 10mm.
- Frame reinforcement angle section: 224mm x 77mm x 4.5mm (cab back). 224mm x 77mm x 6mm (rear axle).
- Material SAPH440 weldable mild steel.

### SUSPENSION

- Semi-elliptical, alloy steel multi-leaf springs. Fully wrapped eye with greasable shackles.

#### FRONT

- 1,470mm x 80mm x 12mm x 2 leaves.  
x 80mm x 13mm x 6 leaves.
- Hydraulic, double acting, telescopic shock absorbers.

#### REAR

- Main: 1,420 x 100mm x 12mm x 8 leaves
- Aux: 980 x 100mm x 10mm x 2 leaves  
980 x 100mm x 11mm x 4 leaves

### BRAKES

- Meritor 'Q Plus' full air 'S' cam dual circuit, front and rear leading and trailing shoes. Drum diameter front and rear 419 mm. Total swept area 8,030cm<sup>2</sup>. Total brake lining area 4,864cm<sup>2</sup>.
- Asbestos free lining material.
- Air tank capacity 78.5 litres in total.
- Nylon brake air tubing.
- Spring park brake acting on rear wheels.
- Air dryer.
- Automatic Slack adjusters.

### STEERING

- Fully integral power assisted recirculating ball type.
- Gear ratio 22.4 : 1. Turns lock to lock 4.5.
- Gear driven vane type oil pump. Oil capacity 2.5 litres.

### WHEELS AND TYRES

- 8.25 x 22.5, 10 stud disc wheels.
- 11R22.5 148/145L tubeless radial tyres front and rear.
- Type: Michelin XZE2 (Front)  
Michelin XDE2 (Rear)
- Load and speed ratings per tyre: 3,150kg (single) / 2,900kg (dual) / 120 km/h.
- Number of wheels and tyres 7, including spare. Winch type spare wheel carrier.

### ELECTRICAL SYSTEM

- Batteries – 2 x 12 volt / 65 amp/h, negative earth.
- Alternator – 24 volt / 60 amp (1.5kW output).
- Starter motor – 24 volt / 4.5 kW.
- Rear stop and tail lamps and licence plate lamp with long leads for variable body mounting.

## ISUZU NEW TRUCK WARRANTIES

STANDARD TRUCKPOWER WARRANTY*			TRUCKPOWER EXTENDED WARRANTY OPTIONS*		
NEW VEHICLE	2 years	100,000km	3 years / 150,000km	4 years / 200,000km	5 years / 250,000km
DRIVETRAIN	3 years	150,000km			
CAB CORROSION	3 years	unlimited			

\* Subject to the conditions outlined in the I-GM New Vehicle Warranty, the Isuzu FVR models carry a standard factory warranty which covers the owner: (i) for the entire vehicle, for the first 24 months or 100,000km (whichever comes first) (ii) for the powertrain, which runs concurrently for 36 months or 150,000km (whichever comes first) (iii) against cab corrosion, for 36 months and unlimited kilometres.

# A TruckPower Extended Warranty as illustrated is available by purchase to cover the owner against the failure of original components, but excludes some components and expendable items such as oil, filters, etc. Please consult with your Isuzu Dealer for full details obtainable from a dedicated brochure available to customers.