

NPR 400 MEDIUM

GVM: 7300kg
GCM: 9000kg
WHEELBASE: 3365mm

400

ISUZU 4HF1 ENGINE PERFORMANCE

- Type: 4 cylinder, OHC diesel, four stroke, direct injection
- Bore x stroke: 112 x 110 mm
- Displacement: 4334 cc
- Compression Ratio: 18.5:1
- Output -
Power:
85kW @ 3200 rpm (DIN Nett)
Torque:
289 Nm @ 1900 rpm (DIN Nett)

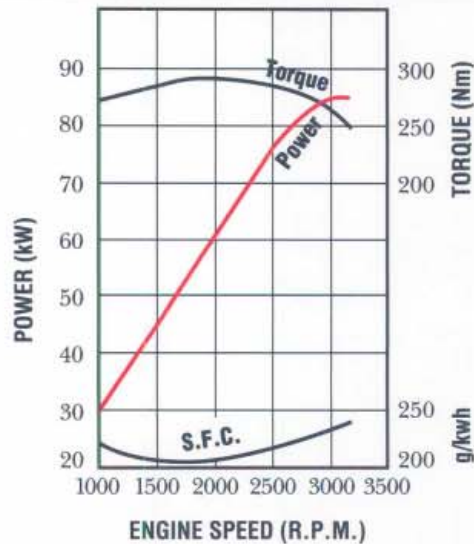

DIMENSIONS AND WEIGHTS

ESTIMATED KERB MASS (kg)	
FRONT	1560
REAR	820
TOTAL	2380
FRAME WIDTH (mm)	750
TURNING CIRCLE (m)	
Kerb to Kerb	12.4
BODY LENGTH (mm)	4570
Subject to weight distribution	
RECOMMENDED MAXIMUM BODY WIDTH (mm)	2300

Chassis and cab with oil, water and fuel tank containing 10 litres of fuel.

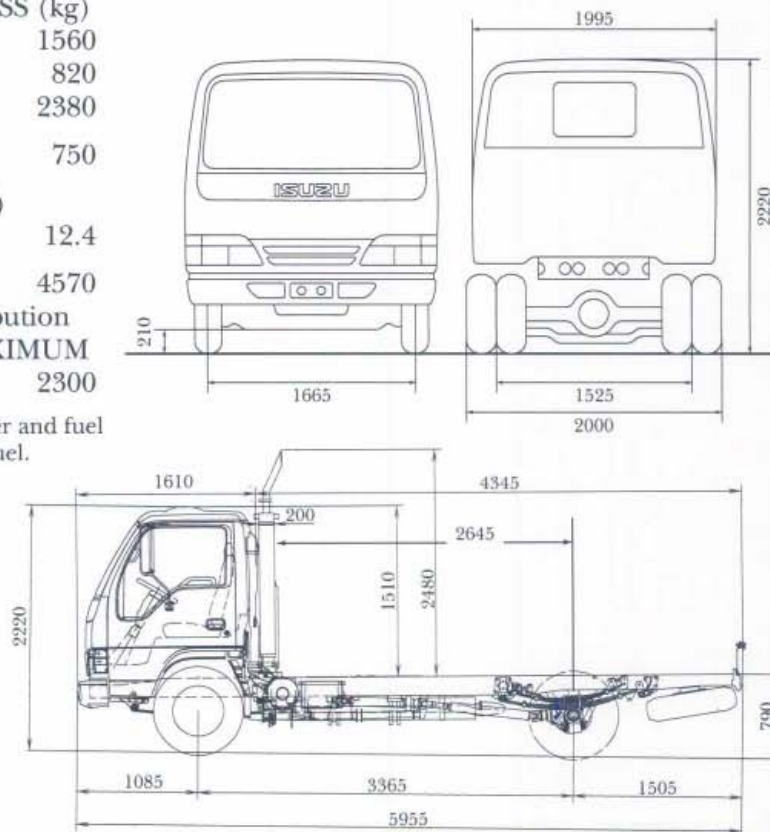

ISUZU-GENERAL MOTORS AUSTRALIA LTD A.C.N. 006 962 572.

12/20 WARRANTY. Every Isuzu Truck is covered by the I-GM new vehicle warranty which covers your vehicle for the first 12 months or 20,000 kilometres.

PLEASE NOTE: as the policy of Isuzu-General Motors Australia Limited is one of continual product improvement, all specifications and equipment are subject to change without notice. Body illustrated is not standard. No I-GM dealer or other person is authorised or permitted to give or make any statement, assertion or undertaking in relation to the quality performance characteristics descriptions or fitness for any purpose of any I-GM product which is at variance with any written statement, assertion or undertaking on any of these subjects given or made by Isuzu-General Motors Australia Limited in its published sales literature, and the company accepts no liability for any such unauthorised action. Isuzu-General Motors Australia Limited has franchised dealers in many parts of Australia, for the sale of service parts and the provision of service to owners of I-GM products. Every endeavour is made to ensure that such dealers carry adequate stocks of service parts, and are equipped to provide satisfactory service, but makes no promise, other than that contained in the New Vehicle Warranty given by Isuzu-General Motors Australia Limited, that such parts or service facilities will be available, or available at any specific location or any particular time.

NPR 400 MEDIUM

ORDERING CODE:
8NS02-22H

400

ENGINE - ISUZU 4HF1

Lubrication:

- Pressure feed lubrication with full flow paper element and partial flow sub filter. Plate type oil cooler in water jacket.

Cooling System:

- Eight blade plastic cooling fan, size 430 mm diameter, with thermatic clutch.
- Tube and corrugated fin pressure type radiator. Size (mm) 547h x 471w x 54t.
- Frontal area 0.258 m².

FUEL SYSTEM

- Cartridge type paper element air cleaner with resonator mounted high up on the chassis, with vertical air intake stack mounted behind cab.
- In line plunger, Bosch 'A' type fuel injection pump with mechanical all speed governor. In line paper filter. Fuel/water sedimentor with warning lamp.
- Fuel tank capacity 115 litres.
- Horizontal exhaust muffler with vertical exhaust stack, with anti-rust coat.

CLUTCH

- Hydraulic control dry single plate with diaphragm spring. Asbestos free clutch plate, with silent disc, 300 mm diameter.
- Total lining area (both sides) 847 cm².

TRANSMISSION ISUZU MXA5R

- 5 speed overdrive, synchromesh with remote control short gear shift lever. Gear ratios: 1

1st	4.987
2nd	2.870
3rd	1.594
4th	1.000
5th	0.728
Reverse	4.774

- Two piece propeller shaft, 82.6 mm diameter

Length: 1st section	830 mm
2nd section	964 mm

- Maximum geared speed 103 km/h.

REAR AXLE-CAPACITY 5000KG

- Banjo type, fully floating, single reduction.
- Ratio 6.142:1 (100P) 5.857:1 (1993).
- Hypoid type ring gear: 292 mm diam.
- Oil capacity 3 litres.

REAR SUSPENSION-CAPACITY 4800KG

- Semi elliptical, alloy steel tapered multi leaf springs, with fully wrapped eye and metalastic bushes.
- Size: length - width x thickness; no. leaves

Main:	1250 - 70 x 10 mm - 1 leaf
	70 x 11 mm - 5 leaves
Auxiliary:	850 - 70 x 9 mm - 1 leaf
	70 x 10 mm - 4 leaves

- Hydraulic, double acting, telescopic shock absorbers, bias mounted.

FRONT AXLE-CAPACITY 2700KG

- Reverse Elliot I-beam type. King pin diameter 30 mm with cylindrical roller thrust bearing.

FRONT SUSPENSION-CAPACITY 2450KG

- Semi elliptical, alloy steel tapered multi-leaf springs, with fully wrapped eye and metalastic bushes.
- Size: length - width x thickness; no. leaves

1140 - 70 x 9 mm - 7 leaves

- Hydraulic, double acting, telescopic shock absorbers.

STEERING

- Fully integral power assisted recirculating ball type. Gear ratio 20.9:1. Turns lock to lock 5.0.
- Steering lock.
- Gear driven vane type oil pump, oil capacity 1.6 litre.
- Lube for life drag link.

BRAKES

- Hydraulic dual circuit, vacuum assisted, front two leading, rear dual two leading (auto adj).
- Drum diameter front and rear 320 mm. Total swept area 4019 cm².
- Asbestos free lining material. Width 100 mm.
- Mechanical park brake, internal expanding at rear of transmission. Lever beside seat.
- Butterfly, vacuum controlled exhaust brake system. Activation switch on wiper/washer control stalk.
- Load sensing proportioning valve.

CHASSIS FRAME

- Ladder type, channel section, cold rivetted.
- Side member dimensions 173 x 65 x 6 mm with 4.5 mm reinforcement.

WHEELS AND TYRES

- 6.00GS x 16 - 6 stud disc wheel, 20 mm bolt size. 127 mm offset.
- 7.50 R - 16 LT - 12 ply Yokohama (highway tread) tyres.
- Number of tyres, 7 including spare.
- Winch type spare wheel carrier, rear mounted.

ELECTRICAL SYSTEM

- Batteries - 2 x 12 volt - 65 amp/h, negative earth.
- Alternator - 24 volt - 35 amp.
- Starter motor - 24 volt - 4.0 kW output.
- Rear stop and tail lamps with long leads for variable body mounting.
- Back-up warning beeper and lamps.

CAB EXTERIOR

- All steel cab, manual tilt to 45°.
- Aluminium non-slip entry steps.
- West Coast type rear view mirrors with clearance lamps.

- Access to fluid checks without tilting cab.
- Tinted, laminated windshield, bonded in position, 2 speed wiper/4 jet washer with intermittent mode.
- 4 rectangular semi-sealed beam headlamps.
- Combination turn signal and park lamps.
- Plastic wheel house liner.

CAB INTERIOR

- Adjustable and reclining driver's bucket seat with lumbar support, 2 place passenger bench seat, with folding back.
- Fire resistant cloth seat material.
- Retractable lap/sash seat belts on outboard seats, lap belt on inboard seat.
- Driver and passenger sun visors, padded roof lining.
- 90° opening, internally reinforced doors, double sealed.
- Tilt telescopic adjustable steering column with soft feel urethane steering wheel.
- Easy access pull down fuse cover.
- Windshield washer tank located under glove compartment.
- Heater demister with 4 speed fan.
- AM/FM stereo radio cassette with digital clock, dash mounted.
- Tool kit with 5000 kg capacity jack.
- Engine access hatch in floor.
- Windshield header shelf.
- Optional air conditioning.

INSTRUMENTATION

- Electronically driven speedometer with odometer and trip meter.
- Tachometer, electronically driven.
- Gauges for coolant temperature and fuel level.

INDICATOR LAMPS

- Turn signals, parking brake on, high beam on, exhaust brake engaged.

WARNING LAMPS

- Battery charge, oil pressure, brake failure, fuel level, coolant level, glow plug and water separator.

SWITCHES

- Left side combination switch for exhaust brake, wipers and washer. Intermittent wipe, washer activated.
- Right side combination switch for turn signals and headlamps.
- Hazard switch.
- Key operation for engine stop/start with quick cold start aid.
- Three way switch for interior lamp activated by driver and passenger doors.
- Fast engine warm-up control.
- Fast engine idle control.