

# 150

NKR 150

GVM 4,200kg  
GCM 6,200kg  
WHEELBASE 2490mm

## ISUZU 4BE1 ENGINE PERFORMANCE

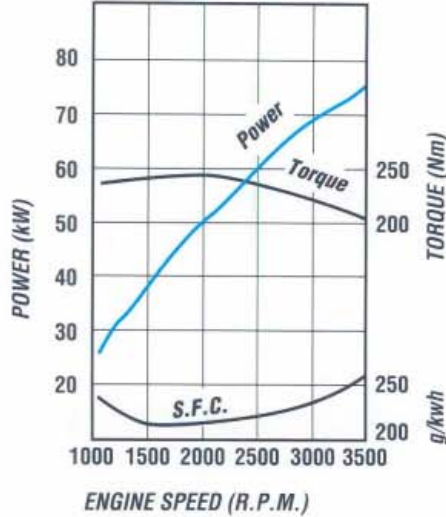

- Type: 4 cylinder OHV diesel, four stroke, direct injection
- Bore x Stroke 105 x 105 mm
- Displacement 3636cc
- Compression Ratio 17.5:1
- Output-Power 75 kW @ 3500 rpm (DIN Nett)
- Torque 242 Nm @ 2000 rpm (DIN Nett)

## DIMENSIONS AND WEIGHTS

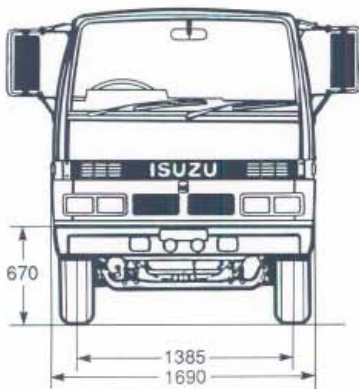
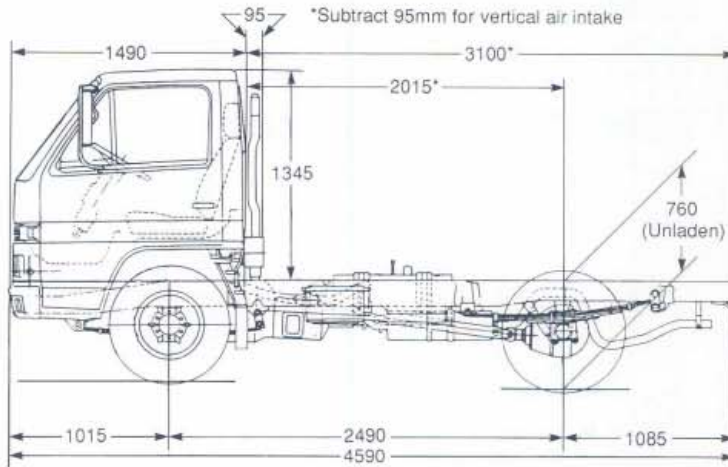

*ESTIMATED KERB MASS (kg)	
FRONT	1210
REAR	520
TOTAL	1730
FRAME WIDTH (mm)	
	800
TURNING CIRCLE (m)	
Kerb to Kerb	11.0
BODY LENGTH (mm)	
	3350
Subject to weight distribution	
RECOMMENDED MAX. BODY WIDTH (mm)	
	2133

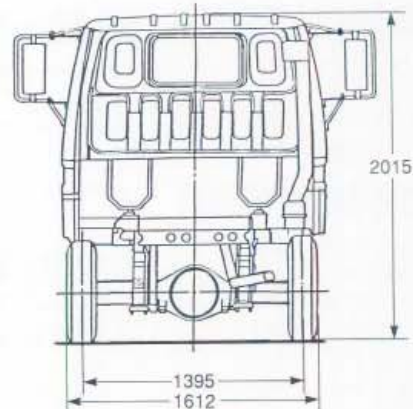

\*Chassis and cab with oil, water and fuel tank containing 10 litres of fuel.

ISUZU-GENERAL MOTORS AUSTRALIA LTD A.C.N. 006 962 572

12/20 WARRANTY. Every Isuzu Truck is covered by the I-GM new vehicle warranty which covers your vehicle for the first 12 months or 20,000 kilometres.

PLEASE NOTE: as the policy of Isuzu-General Motors Australia Limited is one of continual product improvement, all specifications and equipment are subject to change without notice. Body illustrated is not standard. No I-GM dealer or other person is authorised or permitted to give or make any statement, assertion or undertaking in relation to the quality performance characteristics descriptions or fitness for any purpose of any I-GM product or in connection with the supply of any I-GM product which is at variance with any written statement assertion or undertaking on any of these subjects given or made by Isuzu-General Motors Australia Limited in its published sales literature, and the company accepts no liability for any such unauthorised action. Isuzu-General Motors Australia Limited has franchised dealers in many parts of Australia. For the sale of service parts and the provision of service to owners of I-GM products. Every endeavour is made to ensure that such dealers carry adequate stocks of service parts, and are equipped to provide satisfactory service, but makes no promise, other than that contained in the New Vehicle Warranty given by Isuzu-General Motors Australia Limited, that such parts or service facilities will be available, or available at any specific location or any particular time.

CT4215-6/93

ISUZU





# 150

NKR 150

ORDERING CODE:  
8NK02-111

## ENGINE - ISUZU 4BE1

### Lubrication:

- Pressure feed lubrication with full flow paper element and partial flow sub filter. Capacity 7.5 litres including filter.

### Cooling System:

- Eight blade plastic cooling fan, size 400 mm diameter, with thermatic clutch.
- Tube and corrugated fin pressure type radiator. Size (mm) 547 h x 471 w x 54 t. Frontal area 0.258 m<sup>2</sup>.

## FUEL SYSTEM

- Cartridge type paper element air cleaner, mounted behind cab.
- In line plunger, Bosch 'A' type fuel injection pump with mechanical all speed governor. In line paper filter. Fuel/water sedimentor with warning lamp.
- Fuel tank capacity 75 litres.
- Horizontal exhaust muffler and outlet pipe.

## CLUTCH

- Hydraulic control, dry single plate with diaphragm spring asbestos free clutch plate 275 mm diameter. Total lining area (both sides) 679 cm<sup>2</sup>.

## TRANSMISSION ISUZU MSA5G

- Five speed overdrive, synchromesh with remote control short gear lever.
- **Gear ratios:1**

<b>1st</b>	5.788
<b>2nd</b>	2.998
<b>3rd</b>	1.594
<b>4th</b>	1.000
<b>5th</b>	0.776
<b>Reverse</b>	5.798
- Maximum geared speed 120 km/h.
- Single piece propeller shaft, 82.6 mm diameter, length 975 mm.

## REAR AXLE - CAPACITY 3000 KG

- Banjo type, fully floating, single reduction.  
Ratio: 5.375:1.  
Hypoid type ring gear: 292 mm diameter  
Oil capacity: 2.7 litres.

## REAR SUSPENSION - CAPACITY 2700 KG

- Semi elliptical, alloy steel tapered multi leaf springs, with fully wrapped eye.
- Size: length - width x thickness; no. leaves  
Main: 1200 - 70 x 10 mm - 1 leaf  
70 x 11 mm - 2 leaves  
Auxiliary: 760 - 70 x 16 mm - 2 leaves
- Hydraulic, double acting, telescopic shock absorbers.

## FRONT AXLE - CAPACITY 2200 KG

- Reverse Elliot I-beam type. King pin diameter 30 mm with cylindrical roller thrust bearing.

## FRONT SUSPENSION - CAPACITY 2050 KG

- Semi elliptical, alloy steel, tapered multi-leaf springs, with fully wrapped eye.
- Size: length - width x thickness; no. leaves  
1140 - 60 x 8 mm - 2 leaves  
60 x 9 mm - 4 leaves
- Stabiliser bar.
- Hydraulic, double acting, telescopic shock absorbers.

## STEERING

- Fully integral power assisted, recirculating ball type. Gear ratio 22.6:1. Turns lock to lock 4.3.
- Gear driven vane type oil pump. Oil capacity 1.6 litres.

## BRAKES

- Hydraulic dual circuit, vacuum assisted, front two leading, rear dual two leading. Drum diameter front and rear 300 mm. Total swept area 2072.4 cm<sup>2</sup>.
- Asbestos free lining material. Width 55mm.
- Mechanical park brake, internal expanding at rear of transmission.

## CHASSIS FRAME

- Ladder type, channel section, cold rivetted.
- Side member dimensions 170 x 50 x 4.5 mm.

## WHEELS AND TYRES

- 5.50 F x 16 - 6 stud disc wheel, 14 mm bolt size. 25 mm offset.
- Front 7.50 R - 16 LT - 8 ply (Goodyear G22) tyres.
- Rear 7.50 R - 16 LT - 12 ply (Goodyear G22) tyres.
- Option: Front 7.50 - 16 LT - 8 ply (Olympic Trojan 130) tyres. Rear 7.50 - 16 LT - 12 ply (Olympic Trojan 130) tyres (rear).
- Number of tyres 5 including spare.
- Winch type spare wheel carrier.

## ELECTRICAL SYSTEM

- Batteries - 2 x 12 volt - 50 Amp/h, negative earth.
- Alternator - 24 volt - 25 Amp.
- Starter motor - 24 volt - 3.5 kW output.
- Rear stop and tail lamps with long leads for variable body mounting.

## CAB EXTERIOR

- All steel cab, manual tilt to 45°. Aluminium non-slip entry steps.
- West Coast type rear view mirrors with wiring in doors for clearance lamps.
- Access to fluid checks without tilting cab.
- Laminated windshield, 2 speed wiper/washer.
- 4 rectangular sealed beam headlamps.
- Combination turn signal and park lamps.
- Front quarter vent windows.
- Tool kit with 4000 kg capacity jack.
- Engine access hatch in floor.

## CAB INTERIOR

- Adjustable and reclining drivers bucket seat with lumbar support, 2 place passenger bench seat.
- Cloth seat material.
- Retractable lap/sash seat belts on outboard seats, lap belt on inboard seat.
- Driver and passenger sun visors, padded roof lining.
- Soft feel urethane steering wheel.
- Easy access pull down fuse cover.
- Easy entry grab handles on 'A' pillar.
- Windshield washer tank located in passenger door.
- Heater demister with 3 speed fan.
- AM/FM radio with digital clock, dash mounted.
- Optional air conditioning.

## INSTRUMENTATION

- Speedometer with odometer and trip meter.
- Tachometer.
- Gauges for coolant temperature and fuel level.

## INDICATOR LAMPS

- Turn signals, parking brake on, high beam on.

## WARNING LAMPS

- Battery charge, oil pressure, brake failure, fuel level, coolant level, glow plug and water separator.

## SWITCHES

- Left side combination switch for windshield wipers and washer.
- Right side combination switch for turn signals and headlamps.
- Hazard switch.
- Key operation for engine stop start and steering wheel lock.
- Three way interior lamp switch also activated by driver and passenger doors.
- Fast engine warm-up control.