

# ISUZU FRR 500 FRR 500-S

(Crew cab models of FRR 500 also available - refer separate specification sheet)



**ISUZU**  
RELIABILITY IS EVERYTHING

## AT A GLANCE

GVM	10,400 kg
GCM	13,600 - 16,000 kg
Engine Type	Isuzu SiTEC 190 / 220
Displacement	7.8 L
Power	141 kW @ 2,400 rpm 164 kW @ 2,400 rpm
Torque	582 Nm @ 1,500 rpm 668 Nm @ 1,500 rpm
Wheelbase	4,250 - 5,150 mm

### DRIVELINE & CHASSIS SPECIFICATIONS

#### ENGINE:

Type: 6 cylinder, 4 stroke, 24 valve, SOHC, direct injection diesel. Turbocharged and air-to-air intercooled. Adjustable roller type rocker arms.

Displacement: 7,790 cc

Compression Ratio: 16.8:1

Bore x Stroke: 115 x 125 mm

#### FRR 500: SiTEC 190 (ISUZU 6HK1-TCN)

Max power (DIN NET): 141 kW @ 2,400 RPM

Max torque (DIN NET): 582 Nm @ 1,500 RPM

#### FRR 500-S: SiTEC 220 (ISUZU 6HK1-TCC)

Max power (DIN NET): 164 kW @ 2,400 RPM

Max torque (DIN NET): 668 Nm @ 1,500 RPM

- Emissions Standard: ADR 80/00 (USEPA 1998)
- Plate type oil cooler. 13.5 L oil capacity. Combined full flow main filter and bypass oil filter.

#### COOLING SYSTEM

- 8 blade, 640 mm diameter cooling fan with thermostatically controlled viscous clutch. Dual drive belts and thermostats.
- Radiator frontal area: 4,452 cm<sup>2</sup>
- 23 L coolant capacity.

#### AIR INTAKE SYSTEM

- Vertical air intake mounted on back of cab. Two stage Donaldson air cleaner with 280 x 380 mm main element and 160 x 350 mm secondary element.
- 540 x 580 mm air-to-air intercooler.

#### FUEL SYSTEM

- Denso common rail fuel injection. Separate fuel filter and water separator.
- 180 L steel tank.

#### CLUTCH

- Air assisted hydraulic control. Single plate 352 mm (FRR 500), 381 mm (FRR 550-S)
- Asbestos free lining material.
- Total lining area: 1,164 cm<sup>2</sup> (FRR 500)  
1,363 cm<sup>2</sup> (FRR 500-S)

#### TRANSMISSION

##### ISUZU MLD-6Q 6 Speed manual (Medium/Long)

- 6 forward speeds including overdrive.
- Syncromesh on gears 2-6
- 6.5 L oil capacity.
- PTO provision on LHS of transmission case. PTO drive from counter gear.
- Gear ratios (: 1)
 

1st	2nd	3rd	4th	5th	6th	Rev
6.720	4.244	2.580	1.540	1.000	0.763	6.823

##### ALLISON AT545 4 Speed automatic (Auto model)

- 4 forward speeds. Direct drive.
- 18.5 L oil capacity.
- PTO provision on RHS of transmission case.
- Gear ratios (: 1)
 

1st	2nd	3rd	4th	Rev
3.454	2.254	1.407	1.000	5.025

SiTEC 190

Power : 141 kW / 2,400 RPM

Torque : 582 Nm / 1,500 RPM

SiTEC 220

Power : 164 kW / 2,400 RPM

Torque : 668 Nm / 1,500 RPM

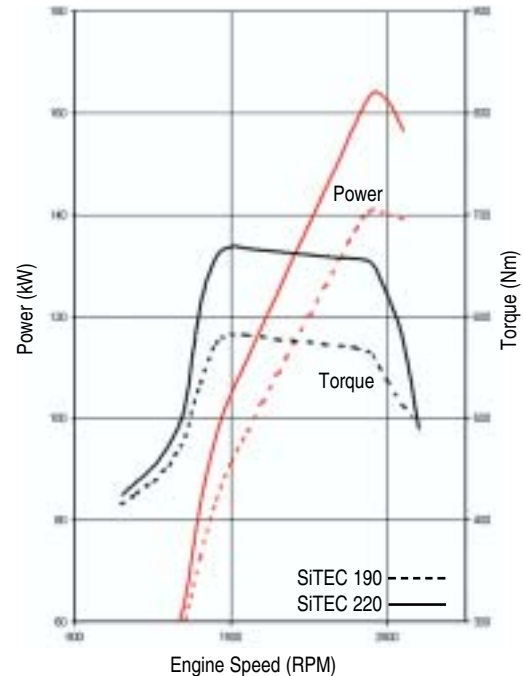

ISUZU SiTEC 190 (6HK1-TCN) & SiTEC 220 (6HK1-TCC) ENGINE PERFORMANCE CHART

#### AXLES

##### FRONT: ISUZU F036

- Reverse Elliot I-beam. 3,600 kg capacity.

##### REAR: ISUZU R077

- Full floating Banjo type. 7,700 kg capacity.
- Drive ratio: 4.875:1 (FRR 500 Medium/Long), 3.909:1 (FRR 500 Auto), 4.333:1 (FRR 500-S)

#### SUSPENSION

##### FRONT

- Single stage, alloy steel, taper leaf springs. Fully wrapped eye with greasable shackles.
- Nominal size: 1,350 x 70 mm
- Total spring capacity (at ground): 3,850 kg
- Double acting hydraulic shock absorbers.

##### REAR

- Two stage, alloy steel, multi-leaf springs. Fully wrapped eye with greasable shackles.
- Nominal size: 1,300 x 70 mm
- Total spring capacity (at ground): 7,330 kg

#### BRAKES

- Dual circuit air over hydraulic brakes
- Front drum diameter: 320 mm
- Rear drum diameter: 320 mm
- Swept area: 5,127 cm<sup>2</sup>
- Asbestos free lining material.
- Medium/Long: 216 mm diameter drum park brake mounted on rear of transmission.
- Auto: Spring type parking brake acting on rear wheels.

- Air controlled exhaust brake (manual models only).
- Total air reservoir capacity: 21 L (man. models), 36 L (auto. model).
- Air dryer.

### **STEERING**

- Power assisted recirculating ball steering.
- 16.1 - 18.8:1 gear ratio.
- 4.1 turns lock to lock.
- 51° wheel cut angle (inside wheel).

### **WHEELS AND TYRES**

- 6.00J x 17.5 Six stud wheels.
- 9.5R17.5 129/127L Michelin XZA Tubeless tyres.
- Maximum tyre rating: 1,850 kg per tyre (single tyres), 1,750 kg per tyre (dual tyres).
- Frame mounted winch type spare wheel carrier. Spare wheel and tyre assembly supplied.

### **AXLE LOAD SUMMARY**

	FRONT	REAR
Axle Capacity (kg):	3,600	7,700
Spring Capacity (kg):	3,850	7,330
Tyre Capacity (kg):	3,700	7,000
<b>Limit (kg):</b>	<b>3,600</b>	<b>7,000</b>

Note: Vehicle loading limit is determined by the combination of axle loading limit, GVM and GCM limit, and government regulatory requirements. Consult your Isuzu dealer to select the correct vehicle for your specific application.

### **CHASSIS FRAME**

- Cold riveted ladder frame with parallel side rails. HT540A high tensile weldable steel.
- Frame dimensions  
Side rail (mm): 225 x 70 x 6.0  
Rear frame width (mm): 840
- Frame reinforcement angle section (Long only).

### **ELECTRICAL SYSTEM**

- 24 Volt electrical system.
- 24 Volt, 60 Amp alternator.
- 24 Volt, 4.5 kW starter motor.
- 2 x 75D23R (520CCA) batteries connected in series.

## **CABIN SPECIFICATIONS AND APPOINTMENTS**

### **CAB EXTERIOR**

- All steel cab, side door impact protection beams. Outer body panels galvanised, corrosion resistant primer treated cab.
- Manual cab tilt to 45°. Access to fluid checkpoints without tilting cab. Front access panel for clutch, windscreen washer fluids and cab air filter screen. Four point silicone filled rubber cab mounting.
- Body coloured steel front bumper with step holes and footplate.
- 90° opening internally reinforced door. Heavy duty aluminium non slip entry steps.
- Tinted, laminated windscreen. 2 speed windscreen wiper system, variable intermittent wipe mode, triple washer jets.
- Halogen headlamps. Park lamps and roof-mounted clearance lamps.
- Combination brake, turn, reverse and marker lamps, registration plate illumination lamps. Extended wiring harness. Reverse alarm.
- "West Coast" type rear view mirrors. Large flat mirror glass with additional, independently adjustable convex "spot" mirror on both sides.

### **CAB INTERIOR**

- Driver's seat with mechanical suspension, 3 way lumbar support, reclining passenger bucket seat, centre seat with folding seat back.
- 3-point, lap sash seatbelts with emergency locking belt retractors in all outboard seating positions. Centre lap seatbelt.
- "A" pillar entry assist grips. Interior lamp with On/Door/Off switch activated by either door.
- Full interior panel trim, padded roof lining, vinyl floor mats. Windscreen header storage shelf. DIN sized aperture in dash for CB. Overhead console fitted with harness for CB.
- Tilt/Telescopic adjustable steering column, soft feel urethane steering wheel.

- 12 Volt, 100 Watt and 24 Volt, 2 pin accessory sockets located in centre console.
- Electric windows.
- Central locking with remote keyless entry.
- Centre facia pullout drinks holder. Lockable compartment on centre seat back.
- Heater/Demister with 4-speed fan and outlets for windscreen, side windows, face and floor.
- Standard fully integrated air conditioning.
- Two speaker Eurovox Radio/CD player with digital anti skip memory.
- Remote seek/volume and mute switch located on dash to right of steering wheel.
- Optional 10 stack CD player.

### **DRIVER CONTROLS**

- Key-operated engine start/stop and steering lock. Electronic throttle control. Engine idle speed control.
- Left side combination stalk: Windscreen wipers, washers, exhaust brake (manual models) and hazard lights.
- Right side combination stalk: Turn signals and headlamps.
- T-bar gear selection (automatic model).

### **INSTRUMENTATION**

- Gauges: Electronically driven speedometer, odometer, tripmeter, tachometer. Gauges for coolant temperature and brake air pressure.
- Warning lamps: Warning bulb check switch. Battery charge, brake system, engine malfunction, oil pressure, stop and tail lamp failure.
- Indicator lamps: Turn signals, parking brake, high beam, exhaust brake engaged.

# FRR 500 Medium / Auto / Long

8FC02-2A0

8FE02-2B0

8FD02-2A0

# FRR 500-S Long

8FD02-2C0

## PERFORMANCE (Calculated)

	FRR 500 MEDIUM / LONG	FRR 500 AUTO	FRR 500-S LONG
Max Geared speed:	111 km/h @ 2,700 rpm	106 km/h @ 2,700 rpm	123 km/h @ 2,650 rpm
Gradeability (lowest gear):	41% at 10,400 kg GVM	34% at 10,400 kg GVM	42% at 10,400 kg GVM
Gradeability (top gear at 100 km/h):	1.3% (2.5 x 2.5 m van body at 10,400 kg GVM)	1.3% (2.5 x 2.5 m van body at 10,400 kg GVM)	1.6% (2.5 x 2.5 m van body at 10,400 kg GVM)
Engine speed (top gear at 100 km/h):	2,430 rpm	2,555 rpm	2,160 rpm

Performance figures quoted are representative only and based on typical dimensions, body styles and weights. Please consult your Isuzu dealer for an estimation based on your specific application.

## MODEL RATINGS AND DIMENSIONS

MODELS	RATINGS (kg)		TARE MASS <sup>#</sup> (kg)			DIMENSIONS (mm)												TURN CIRCLE KERB TO KERB
	GVM	GCM	TOTAL	FRONT	REAR	WB	OAL	FOH	ROH	CA	CE	RT	ORT	CH	CW	FFH UNLADEN	RFH UNLADEN	
FRR 500 Medium	10,400	16,000	3,185	2,135	1,050	4,250	7,195	1,160	1,785	3,455	5,240	1,660	2,165	2,595	2,200	825	860	13.4 m
FRR 500 Auto	10,400	13,600	3,165	2,090	1,075	4,250	7,195	1,160	1,785	3,455	5,240	1,660	2,165	2,595	2,200	825	860	13.4 m
FRR 500 Long	10,400	16,000	3,300	2,190	1,110	5,150	8,595	1,160	2,285	4,355	6,640	1,660	2,165	2,605	2,200	825	900	15.7 m
FRR 500-S Long	10,400	16,000	3,330	2,200	1,130	5,150	8,595	1,160	2,285	4,355	6,640	1,660	2,165	2,605	2,200	825	900	15.7 m

<sup>#</sup> Estimated mass of cab/chassis with oil, water and fuel tank containing 10 litres of fuel and excluding spare wheel (47 kg) and tools (30 kg).

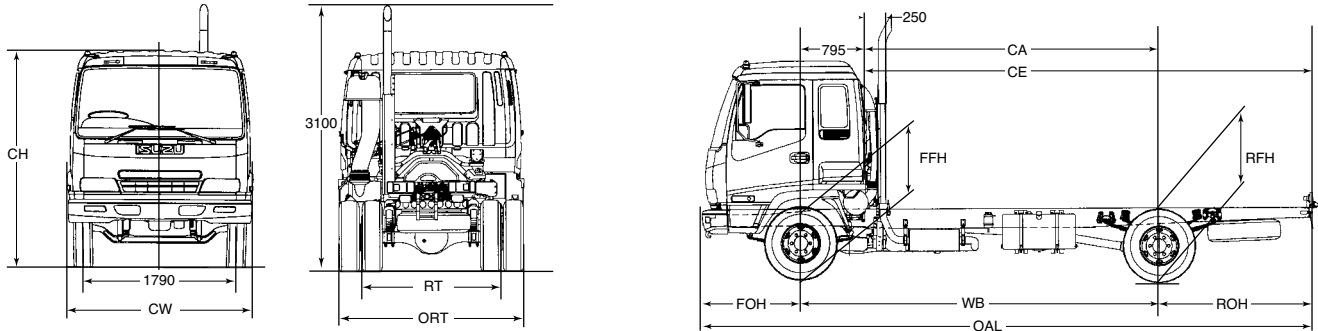

For further information regarding Cab/Chassis dimensions your Isuzu Dealer can access detailed Body Builders diagrams from the Isuzu Truck Technical Reference CD.

## ISUZU NEW TRUCK WARRANTIES

STANDARD TRUCKPOWER WARRANTY*			TRUCKPOWER EXTENDED WARRANTY OPTIONS <sup>#</sup>		
NEW VEHICLE	3 years	150,000 km	4 years / 250,000 km	5 years / 300,000 km	6 years / 350,000 km
DRIVETRAIN	3 years	150,000 km			
CAB CORROSION	3 years	unlimited			

### Why have Isuzu Trucks been Australia's No. 1 choice since 1989? \*

- Widest range of models to suit most applications
- Premium componentry and Isuzu diesel engines
- Network of over 40 specialist Isuzu Dealerships and branches
- Sales, services and parts support
- Predictable operating costs through Dealer ISIS program
- Factory and range of extended warranties available
- High resale values
- Leading reputation for reliability

[www.isuzu.com.au](http://www.isuzu.com.au)

\* Source Truck Tracker 2002

\* Subject to the conditions outlined in the I-GM New Vehicle Warranty, the Isuzu FRR models carry a standard factory warranty which covers the owner: (i) for the entire vehicle, for the first 36 months or 150,000 km (whichever comes first). (ii) for the drivetrain, which runs concurrently, for 36 months or 150,000 km (whichever comes first). (iii) against cab corrosion, for 36 months and unlimited kilometres.

<sup>#</sup> A TruckPower Extended Warranty as illustrated is available by purchase to cover the owner against the failure of original components, but excludes some components and expendable items such as oil, filters, etc. Please consult with your Isuzu Dealer for full details obtained from a dedicated brochure available to customers.

ISUZU-GENERAL MOTORS AUSTRALIA LTD A.C.N. 006 962 572. PLEASE NOTE: as the policy of I-GM is one of continual product improvement, all specifications and equipment are subject to change without notice. No I-GM dealer or other person is authorised or permitted to give or make any statement, assertion or undertaking in relation to the quality, performance, characteristics, descriptions or fitness for any purpose of any I-GM product or in connection with the supply of any I-GM product which is at variance with any written statement, assertion or undertaking on any of these subjects given or made by I-GM in its published sales literature, and the company accepts no liability for any such unauthorised action. I-GM has franchised dealers in many parts of Australia, for the sale of service, parts and the provision of service to the owners of I-GM products. Every endeavour is made to ensure that such dealers carry adequate stocks of service parts and are equipped to provide satisfactory service, but makes no promise, other than that contained in the I-GM new vehicle warranty, that such parts or service facilities will be available or available at any specific location or at any particular time. A word about this specification sheet. We have tried to make it as comprehensive and factual as possible. However, since the time of printing some of the information you will find here may have been updated. Also, some of the equipment shown or described through this specification sheet may have been changed and/or is available at extra cost. And the right is reserved to make changes at any time without notice, in prices, colours, materials, equipment and models. Your I-GM dealer has details and before ordering, you should ask him/her to bring you up to date.

SEPTEMBER 2003. ARK/GM 0087

# ISUZU

RELIABILITY IS EVERYTHING