

ISUZU

SPECIFICATIONS

FTS 800 4x4

FTS 800 4x4 Crew



FTS 800 Crew



FTS 800

AUSTRALIA'S TOP SELLING TRUCK BRAND SINCE 1989.

AT A GLANCE

GVM	13,900 kg*
GCM	18,000 kg (off road)* 20,500 kg (on road)*
Power	176 kW @ 2,400 rpm
Torque	706 Nm @ 1,450 rpm

* Refer to back page weights table for details

ADVANCED TECHNOLOGY

Emissions: Euro V / ADR 80/03	90 amp alternator
Meets EEV emissions standard	Full time 4WD with centre differential lock
Driver and passenger airbag with seatbelt pretensioner	Cruise control
ADR42 compliant sleeper - except crew	Isri 6860 seat with integrated seatbelt
ECE-R29 compliant cab	Electric mirrors



We
share
the
load.

ISUZU
RELIABILITY IS EVERYTHING

FTS 4x4 Standard | PTO | Auto | Crew

Crew PTO | Crew Auto

DRIVELINE AND CHASSIS SPECIFICATIONS

ENGINE: SITEC SERIES III 235 (ISUZU 6HK1-TCN)

Type: 6 cylinder 24 valve SOHC
Displacement: 7,790 cc
Compression Ratio: 17.5:1
Bore x Stroke: 115 x 125 mm
Max power (DIN-NET): 176 kW (236 HP) @ 2,400 RPM
(JIS Gross): 182 kW (244 HP) @ 2,400 RPM
Max torque (DIN-NET): 706 Nm (521 lb.ft) @ 1,450 RPM
(JIS Gross): 731 Nm (539 lb.ft) @ 1,450 RPM
Induction system: Electronically controlled variable nozzle turbocharger with air-to-air intercooler.

Fuel injection: Direct injection high pressure common rail system.

Emission control system: Cooled EGR with exhaust Diesel Particulate Diffuser (DPD). ADR 80/03 (Euro V) compliant. EEV compliant.

ENGINE DRIVEN PTO (PTO models only):

- Constant mesh. Rotates at 0.7 x engine speed.
- 353 Nm maximum output torque.
- Anti-clockwise rotation when viewed from rear of engine.

CLUTCH (MANUAL TRANSMISSION MODEL)

- Air assisted hydraulic control. Single plate 381 mm diameter.
- Total lining area: 1,363 cm²

TRANSMISSION

ISUZU MZW-6P (except auto model)

- 6 speed manual with air assisted shift.
- Synchromesh on gears 2-6. Triple cone synchromesh on 2nd and 3rd gears. Integral oil pump provides full pressure lubrication.
- PTO provision on LHS of transmission case. PTO drive from mainshaft gear.

Gear ratios (:1)

1st	2nd	3rd	4th	5th	6th	Rev
6.615	4.095	2.358	1.531	1.000	0.722	6.615

ALLISON LCT2500 (auto model)

- 6 speed automatic. 5th generation electronic controls with adaptive shift.
- LHS and RHS PTO openings on transmission case. Torque convertor turbine driven PTO drive gear.

Gear ratios (:1)

1st	2nd	3rd	4th	5th	6th	Rev
3.51	1.90	1.44	1.00	0.74	0.64	5.09

TRANSFER GEARBOX: ISUZU TF56

- Full time 4WD with driver activated centre differential lock.
- High ratio 1.00:1, low ratio 1.913:1

AXLES

Front: Isuzu FD047

- Full floating Banjo type. Birfield outer joints and permanently engaged hubs. 4,700 kg capacity.
- Drive ratio 5.571:1 (manual model). 6.500:1 (auto model).

Rear: Isuzu R092

- Full floating Banjo type. 'No-spin' differential lock. 9,200 kg capacity.
- Drive ratio: 5.571:1 (manual model). 6.500:1 (auto model).

SUSPENSION

Front:

- Single stage alloy steel taper leaf springs.
- Double acting hydraulic shock absorbers.

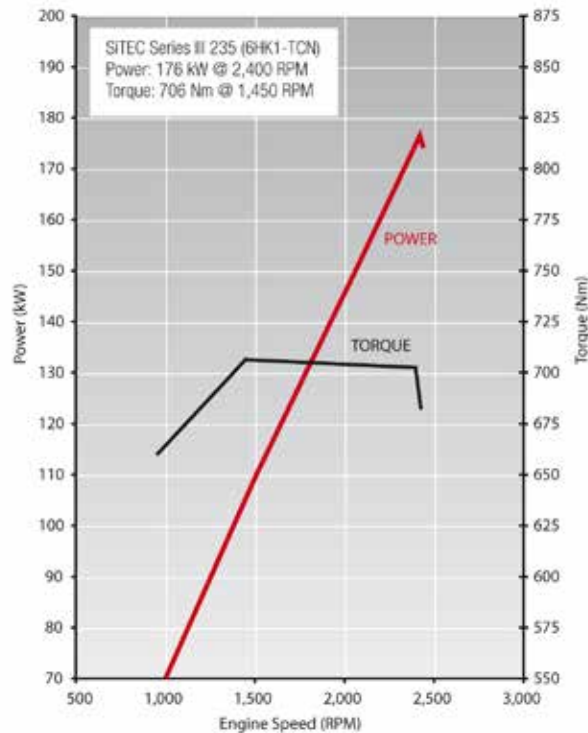

Rear:

- Multi leaf main spring, multi leaf helper spring.

BRAKES

- Dual circuit air over hydraulic front and rear drum brakes.
- ABS.
- Front drum size: 410 x 140 mm
- Rear drum size: 410 x 140 mm
- Spring park brake.
- Air controlled exhaust brake.
- Air dryer.

STEERING

- Power assisted recirculating ball steering.
- Gear ratio: 18.1 - 22.4:1
- Turns lock to lock: 3.5
- Maximum angle: 34° (inside wheel) / 29° (outside wheel)

WHEELS AND TYRES

- 22.5 x 7.50 eight stud steel wheels.
- Steer axle: 11R22.5 148/145K Michelin XZY 3 Tubeless
- Drive axle: 11R22.5 148/145K Michelin XDY 3 Tubeless
- Maximum tyre rating:
 - Front axle: 6,300 kg
 - Rear axle: 11,600 kg
- Spare wheel and tyre assembly with winch type carrier.

CHASSIS FRAME

- Cold rivetted ladder frame with parallel side rails. HT540A high tensile weldable steel sidemembers.
- Frame dimensions:
 - Side rail (mm): 253 x 80 x 7.5
 - Rear frame width (mm): 850

FUEL TANK

- Frame mounted 200L steel fuel tank.
- Lockable fuel cap.

ELECTRICAL SYSTEM

- 24 volt electrical system.
- 90 amp alternator.

CABIN SPECIFICATIONS AND APPOINTMENTS

CAB EXTERIOR

- All steel construction. High tensile steel used for cab underframe.
Single cab: Manual cab tilt to 45° with torsion bar assistance.
Crew cab: Electro-hydraulic cab tilt.
- Complies with ECE-R29 cab strength standard.
- **Single cab:** Liquid filled front and rear cab mounts.
Crew cab: Rubber cab mounts.
- Heavy duty non slip entry steps.
- 90° opening internally reinforced front doors.
- Water spray suppression guards and front mudflaps.
- Laminated windscreen with shade band.
- Two speed windscreen wipers, with intermittent wipe mode.
- Halogen multi-reflector headlamps. Front panel mounted turn signals. Additional door mounted side indicator lamps.
- Combination brake, turn, reverse and marker lamps, registration plate illumination lamps. Extended wiring harness. Reverse alarm.
- Roof-mounted clearance lamps.
- Heated and powered exterior main mirrors with flat glass and additional powered convex "spot" mirrors.
- Body coloured grille.
- Body coloured steel air dam bumper.

CAB INTERIOR

- Isri 6860 air suspension driver's seat with pneumatic lumbar support, height, rake and automatic weight adjustment.
- Front passenger adjustable bucket seat and front centre seat with folding seat back.
- **Crew cab:** Rear bench seat with 4 seat capacity.
- 3-point lap sash seatbelts in all outboard seating positions. Driver seatbelt with pretensioner integrated with driver seat. Outboard front passenger seatbelt fitted with pretensioner. Centre seat lap belts.
- **Single cab:** ADR42 compliant sleeper.
- Driver and outboard front passenger airbag.
- Door and roof pillar entry assist grips. **Crew cab:** Full width rear grab rail with ashtray.
- Full interior trim, padded roof lining and vinyl floor covering. Driver and passenger windscreen header storage shelf.
- Tilt/Telescopic adjustable steering column, soft feel urethane steering wheel.
- Electric windows.
- Central locking with remote keyless entry and immobiliser.
- Twin cup holders. 24V cigarette lighter. Dashboard hook.
- Front door mounted storage pockets and driver's side ashtray.
- Centre console box with storage tray. Fold down storage tray behind centre seat backrest.
- Fully integrated air conditioning and heater/demister with 4-speed fan and outlets for windscreen, side windows, face and floor.
- Fluorescent type interior lamp with On/Door/Off switch.

- 24 Volt, 4.5 kW starter motor.
- **Single cab:** 2 x 115E41L (651 CCA) batteries connected in series.
Crew cab: 2 x 80D26L (630 CCA) batteries connected in series.
- Underdash CAN interface unit and connector. SAE J1939 protocol. Facilitates connection to a Fleet Management System (FMS) (not supplied).

- 2 DIN, two speaker radio/CD/DVD Digital Audio Visual Entertainment (DAVE) unit with 6.2" LCD touch screen. DAB+ digital radio and fully integrated Bluetooth with voice recognition. 4GB internal storage for music files. USB/SD card and auxiliary input connection provisions.
- DIN sized compartment for storage or for CB radio installation.

DRIVER CONTROLS

- Key-operated engine start/stop and steering lock. Engine idle speed control.
- DPD regeneration.
- High/low range and centre differential lock switches.
- T-bar gear selection control (auto model).
- **Left side combination stalk:** Windscreen wipers, washers and exhaust brake.
- **Right side combination stalk:** Turn signals, headlamps and cruise control.

INSTRUMENTATION

- Electronically driven speedometer and tachometer. Digital odometer with integrated dual tripmeter. Engine coolant temperature, fuel level and air pressure gauges.
- **Warning lamps:** Check engine, oil pressure, ABS, SRS airbag, alternator charge, service brakes, park brake, seatbelt unfastened, low air pressure, low fuel level, cab lock.
- **Indicator lamps:** Warm up system, high beam, DPD status, exhaust brake, low range engaged, centre differential lock engaged, turn signals, cruise control.
- Multi-information display. Shows service interval, instantaneous and average fuel consumption, DPD bar chart, hourmeter, voltmeter, time/day/date and includes 40-120 km/h adjustable vehicle speed warning.

OPTIONS AND GENUINE ACCESSORIES

Include the following (extra cost, request a brochure and further details from your Isuzu dealer):

Digital Audio Visual Entertainment unit:

- Isuzu satellite navigation including three years of free updates.
- Up to four reversing cameras - one with audio for reversing. Reversing sensors.
- Tyre pressure monitoring system.
- Cables for full iPod / iPhone / iPad compatibility and connection to other external audio visual devices.

Other:

- Airbag compatible bullbar.
- Air deflector.

ISUZU CARE

Isuzu Care gives truck owners access to products and services including Roadside Assist, Service Agreements, Extended Care, Extended Isuzu Assist and the Isuzu Care Centre. Call 1800 035 640.

WEIGHTS (kg)

Models	Ratings*		Loading Limit* (at ground)		Cab Chassis Mass #		
	GVM	GCM	Front	Rear	Front	Rear	Total
FTS 800	13,900	18,000 kg (off road) 20,500 kg (on road)	4,700	9,200	3,225	2,040	5,265
FTS 800 PTO	13,900	18,000 kg (off road) 20,500 kg (on road)	4,700	9,200	3,285	2,055	5,340
FTS 800 Auto	13,900**	18,000 kg (off road)** 20,500 kg (on road)**	4,700	9,200	3,175	2,060	5,235
FTS 800 Crew	13,900	18,000 kg (off road) 20,500 kg (on road)	4,700	9,200	3,325	2,100	5,425
FTS 800 Crew PTO	13,900	18,000 kg (off road) 20,500 kg (on road)	4,700	9,200	3,385	2,115	5,500
FTS 800 Crew Auto	13,900**	18,000 kg (off road)** 20,500 kg (on road)**	4,700	9,200	3,275	2,120	5,395

* Vehicle ratings and front/rear weight limits are subject to government regulatory requirements and weight distribution analysis. Consult your Isuzu dealer to select the correct vehicle for your specific application. ** Pre-approved ratings as stated apply for general transport and distribution applications. For other applications approval from Allison is required. For example, GVM and GCM limits of 12,000kg apply for refuse application. # Cab chassis only as supplied and including 10 litres of fuel.

DIMENSIONS (mm)

Turn Circle (m)

Models	WB	OAL	FOH	ROH	EA	CE	RT	ORT	CH	FFA (unladen)	RFA (unladen)	RFH (unladen)	KERB TO KERB
FTS 800	4,250	7,405	1,255	1,900	3,350	5,340	1,795	2,365	2,935	1,125	1,185	1,220	17.5
FTS 800 Auto	4,250	7,405	1,255	1,900	3,350	5,340	1,795	2,365	2,955	1,145	1,240	1,285	17.5
FTS 800 Crew	4,250	7,405	1,255	1,900	2,625	4,648	1,795	2,365	3,070	1,120	1,185	1,220	17.5
FTS 800 Crew Auto	4,250	7,405	1,255	1,900	2,625	4,648	1,795	2,365	3,090	1,140	1,245	1,290	17.5

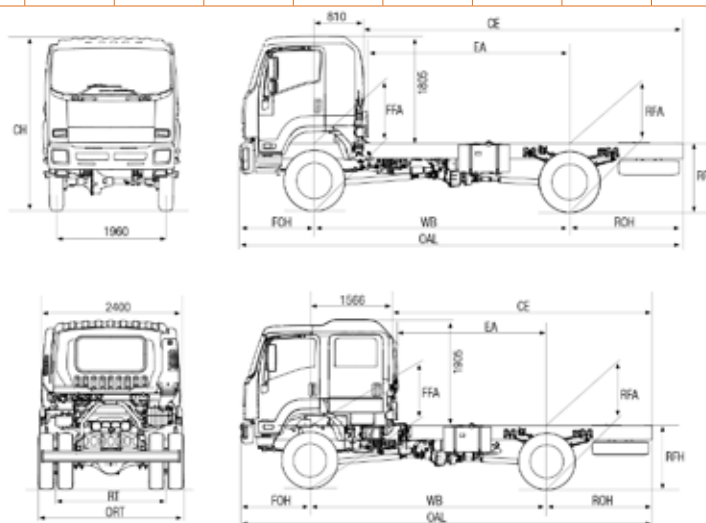

PERFORMANCE (calculated - typical paved road)

		Geared Speed* (top gear at peak power engine RPM)	Low Speed Gradeability (lowest forward gear assuming no wheel slip)	Engine Speed (top gear at 100km/h)
FTS 800 4x4	At 13,900kg GVM	116 km/h @ 2,400 RPM	62%	2,065 RPM
FTS 800 4x4 Auto	At 13,900kg GVM	112 km/h @ 2,400 RPM	60%	2,135 RPM

*Maximum speed achievable depends on vehicle frontal area as well as other factors. Consult your Isuzu dealer for more detailed information. Vehicle speed is limited to 100 km/h.

ISUZU WARRANTIES

STANDARD ¹	
New Vehicle	3 years • 150,000km • 2,500 hours
Cab Perforation Corrosion	3 years • unlimited km's
Isuzu Assist: 24 hour roadside assistance (3 years, unlimited km's)*	
EXTENDED CARE ²	
On application only	

ORDER CODES

Model	Code	Model	Code
FTS 800	FH-FTSJF-B14	FTS 800 Crew	FH-FTSLF-B14
FTS 800 PTO	FH-FTSJG-B14	FTS 800 Crew PTO	FH-FTSLG-B14
FTS 800 Auto	FH-FTSJF-L14	FTS 800 Crew Auto	FH-FTSLF-L14

¹ Subject to the conditions outlined in the IAL New Vehicle Warranty, the Isuzu FTS models carry a standard factory warranty which covers the owner: (i) for the entire vehicle, for the first 36 months or 150,000 km or 2,500 hrs (whichever comes first), (ii) against cab perforation corrosion, for 36 months and unlimited kilometres. ² Extended Warranty as illustrated may be purchased to cover the owner against the failure of original components, but may exclude some components and expendable items such as oil, filters, etc. *Valid for three years from the date of new vehicle purchases. All Isuzu warranties are subject to mandatory prescribed terms under Australian Consumer law including customer guarantees. For more details visit the Isuzu website which explains Isuzu warranties in more detail, or alternatively contact your local dealer. All warranties commence from date of delivery.

ISUZU AUSTRALIA LIMITED ABN 97 006 962 572 ("IAL"). The information in this spec sheet was correct at time of printing, but all measurements, specifications and equipment are subject to change without notice. Some equipment may have been changed and/or is available at extra cost. IAL may make changes at any time without notice, in prices, colours, materials, equipment and models. IAL makes all reasonable attempts to ensure the availability of all vehicles and equipment. The information in this spec sheet is general in nature. Your Isuzu dealer can confirm all measurements, specifications and vehicle / equipment availability upon request. To the extent permitted by the law, IAL is not liable to any person as result of reliance on the content of this spec sheet.

March 2014. ARK0738

We
share
the
load.

ISUZU
RELIABILITY IS EVERYTHING