

400

NPR 400 TURBO

**GVM 7,000kg
GCM 9,000kg
WHEELBASE 3815mm**

ISUZU 4BD1-T ENGINE PERFORMANCE

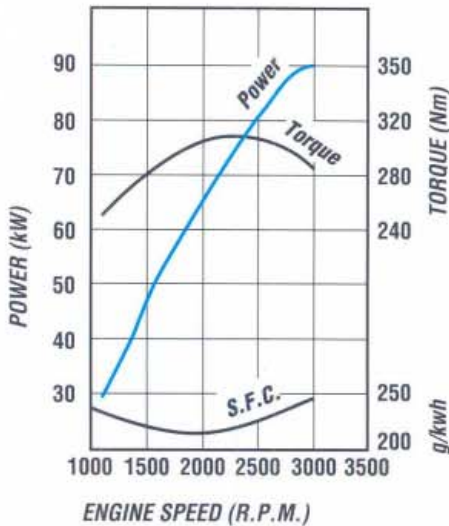

- Type: 4 cylinder turbocharged OHV diesel, four stroke, direct injection
- Bore x stroke: 102 x 118 mm
- Displacement: 3856 cc
- Compression Ratio: 17.0:1
- Output - Power: 90 kW @ 3000 rpm (DIN Nett)
- Torque: 314 Nm @ 2200 rpm (DIN Nett)

DIMENSIONS AND WEIGHTS

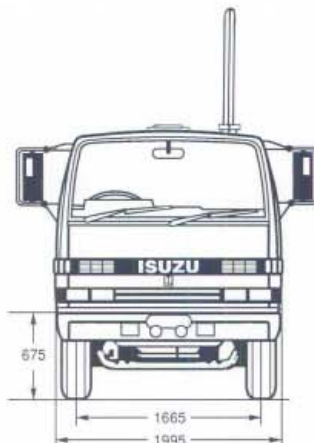
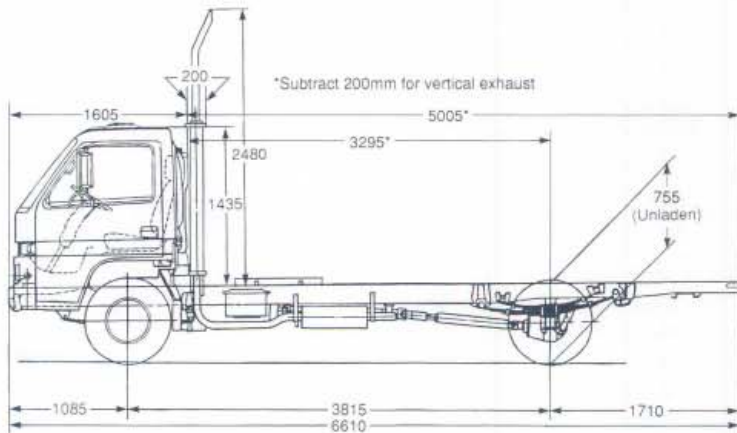

*ESTIMATED KERB MASS (kg)	
FRONT	1500
REAR	830
TOTAL	2330
FRAME WIDTH (mm)	750
TURNING CIRCLE (m)	
Kerb to Kerb	14.4
BODY LENGTH (mm)	5330
Subject to weight distribution	
RECOMMENDED MAX. BODY WIDTH (mm)	2286

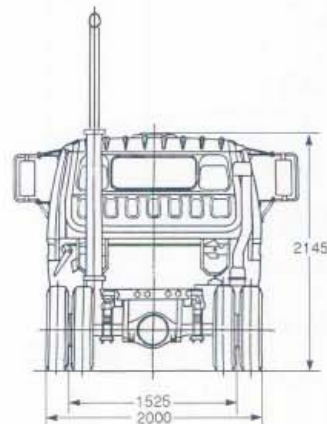

*Chassis and cab with oil, water and fuel tank containing 10 litres of fuel.

ISUZU-GENERAL MOTORS AUSTRALIA LTD A.C.N. 006 962 572

1220 WARRANTY. Every Isuzu Truck is covered by the I-GM new vehicle warranty which covers your vehicle for the first 12 months or 20,000 kilometres.

PLEASE NOTE: as the policy of Isuzu-General Motors Australia Limited is one of continual product improvement, all specifications and equipment are subject to change without notice. Body illustrated is not standard. No I-GM dealer or other person is authorised or permitted to give or make any statement, assertion or undertaking in relation to the quality performance characteristics descriptions or fitness for any purpose of any I-GM product or in connection with the supply of any I-GM product which is at variance with any written statement assertion or undertaking on any of these subjects given or made by Isuzu-General Motors Australia Limited in its published sales literature, and the company accepts no liability for any such unauthorised action. Isuzu-General Motors Australia Limited has franchised dealers in many parts of Australia. For the sale of service parts and the provision of service to owners of I-GM products. Every endeavour is made to ensure that such dealers carry adequate stocks of service parts, and are equipped to provide satisfactory service, but makes no promise, other than that contained in the New Vehicle Warranty given by Isuzu-General Motors Australia Limited, that such parts or service facilities will be available, or available at any specific location or any particular time.

CT4228-6/93

ISUZU





400

NPR 400 TURBO

ORDERING CODE:
8NT02-231

ENGINE - ISUZU 4BD1-T

Lubrication

- Pressure feed lubrication with full flow paper element and partial flow sub filter, capacity 8.8 litres including filter. Plate type oil cooler in water jacket.

Cooling System

- Eight blade plastic cooling fan, size 400 mm diameter, with thermatic clutch.
- Tube and corrugated fin pressure type radiator. Size (mm) 547 h x 471 w x 54 t. Frontal area 0.258 m².

FUEL SYSTEM

- Cartridge type paper element air cleaner, mounted high up on the chassis, with vertical air intake stack mounted behind cab.
- In line plunger, Bosch 'A' type fuel injection pump with mechanical all speed governor. In line paper filter. Fuel/water sedimentor with warning lamp.
- Fuel tank capacity 125 litres.
- Horizontal exhaust muffler with vertical exhaust stack.

CLUTCH

- Hydraulic control, dry single plate with diaphragm spring, asbestos free clutch plate, 300 mm diameter. Total lining area (both sides) 847 cm².

TRANSMISSION ISUZU MSA5S

- Five speed overdrive, synchromesh with dual range shift, oil capacity 3.2 litres.
- **Gear ratios:1**

1st	4.987
2nd	2.870
3rd	1.684
4th	1.000
5th	0.728
Reverse	4.777
- **Supershift gear ratios:1**

Economy	0.762
Power	1.000
- Maximum geared speed 136 km/h.
- 2 piece propellor shaft 82.6 mm diameter length

1st section	1086 mm
2nd section	964 mm

REAR AXLE - CAPACITY 5000 KG

- Banjo type, fully floating, single reduction. Ratio 6.142:1.
- Hypoid type ring gear: 292 mm diameter. Oil capacity 3 litres.

REAR SUSPENSION - CAPACITY 4800 KG

- Semi elliptical, alloy steel, tapered multi leaf springs, with fully wrapped eye.
- Size: length - width x thickness; no. leaves
Main: 1250 - 70 x 10 mm - 1 leaf
70 x 11 mm - 5 leaves
Auxiliary: 850 - 70 x 9 mm - 1 leaf
70 x 10 mm - 4 leaves
- Hydraulic, double acting, telescopic shock absorbers.

FRONT AXLE - CAPACITY 2700 KG

- Reverse Elliot, I-beam type, king pin diameter 30 mm with cylindrical roller thrust bearing.

FRONT SUSPENSION - CAPACITY 2450 KG

- Semi elliptical, alloy steel, tapered multi-leaf springs, with fully wrapped eye.
- Size: length - width x thickness; no. leaves
1140 - 70 x 9 mm - 7 leaves
- Hydraulic, double acting, telescopic shock absorbers.

STEERING

- Fully integral power assisted recirculating ball type. Gear ratio 21.9:1. Turns lock to lock 5.0.
- Gear driven vane type oil pump, oil capacity 1.6 litres.

BRAKES

- Hydraulic dual circuit, vacuum assisted, front two leading, rear dual two leading. Drum diameter front and rear 320 mm. Total swept area 4019 cm².
- Asbestos free lining material. Width 100mm.
- Mechanical park brake, internal expanding at rear of transmission.
- Butterfly, vacuum controlled exhaust brake system. Activation switch on wiper/washer control stalk.

CHASSIS FRAME

- Ladder type, channel section, cold rivetted.
- Side member dimensions 173 x 65 x 6 mm with 4.5 mm reinforcement.

WHEELS AND TYRES

- 6.00 GS x 16 - 6 stud disc wheel, 20 mm bolt size. 127 mm offset.
- 7.50 R - 16 LT - 12 ply (Goodyear G22) tyres.
- Number of tyres, 7 including spare.
- Winch type spare wheel carrier.

ELECTRICAL SYSTEM

- Batteries - 2 x 12 volt - 50 amp/h, negative earth.
- Alternator - 24 volt - 25 amp.
- Starter motor - 24 volt - 4.5 kW output.
- Rear stop and tail lamps with long leads for variable body mounting.

CAB EXTERIOR

- All steel cab, manual tilt to 45°, non-slip aluminium entry steps.
- West Coast type rear view mirrors with clearance lamps.
- Access to fluid checks without tilting cab.
- Laminated windshield, 2 speed wiper/washer with intermittent mode.
- 4 rectangular sealed beam headlamps.
- Combination turn signal and park lamps.
- Front quarter vent windows.
- Cab roof air vent with fore and aft tilt.
- Tool kit with 5000 kg capacity jack.
- Engine access hatch in floor.

CAB INTERIOR

- Adjustable and reclining drivers bucket seat with lumbar support, 2 place passenger bench seat.
- Cloth seat material.
- Retractable lap/sash seat belts on outboard seats, lap belt on inboard seat.
- Driver and passenger sun visors, padded roof lining.
- Soft feel urethane steering wheel.
- Easy access pull down fuse cover.
- Easy entry grab handles on 'A' pillar.
- Windshield washer tank located in passenger door.
- Heater demister with 3 speed fan.
- AM/FM radio with digital clock, dash mounted.
- Optional air conditioning.

INSTRUMENTATION

- Speedometer with odometer and trip meter
- Tachometer.
- Gauges for coolant temperature and fuel level.

INDICATOR LAMPS

- Turn signals, parking brake on, high beam on, exhaust brake engaged.

WARNING LAMPS

- Battery charge, oil pressure, brake failure, fuel level, coolant level, glow plug and water separator.

SWITCHES

- Left side combination switch for exhaust, brake, wipers and washer.
- Right side combination switch for turn signals and headlamps.
- Hazard switch.
- Key operation for engine stop start and steering wheel lock.
- Three way switch for interior lamp activated by driver and passenger doors.
- Fast engine warm-up control.