

ISUZU FSS 550 4x4 FTS 750 4x4

(Crew cab models also available - refer separate specification sheet)



ISUZU
RELIABILITY IS EVERYTHING

AT A GLANCE

GVM	10,000 - 13,000 kg
GCM	FSS: 15,000 kg FTS: 20,500 kg (on road) 18,000 kg (off road)
Engine Type	Isuzu SiTEC 190 / 220
Displacement	7.8 L
Power	141 kW @ 2,400 rpm 164 kW @ 2,400 rpm
Torque	582 Nm @ 1,500 rpm 668 Nm @ 1,500 rpm
Wheelbase	3,700 - 4,250 mm

DRIVELINE & CHASSIS SPECIFICATIONS

ENGINE:

Type: 6 cylinder, 4 stroke, 24 valve, SOHC, direct injection diesel. Turbocharged and air-to-air intercooled. Adjustable roller type rocker arms.

Displacement: 7,790 cc

Compression Ratio: 16.8:1

Bore x Stroke: 115 x 125 mm

FSS: SITEC 190 (ISUZU 6HK1-TCN)

Max power (DIN NET): 141 kW @ 2,400 RPM

Max torque (DIN NET): 582 Nm @ 1,500 RPM

FTS: SITEC 220 (ISUZU 6HK1-TCC)

Max power (DIN NET): 164 kW @ 2,400 RPM

Max torque (DIN NET): 668 Nm @ 1,500 RPM

- Emissions Standard: ADR 80/00 (USEPA 1998)
- Plate type oil cooler. 13.5 L oil capacity. Combined full flow main filter and bypass oil filter.

COOLING SYSTEM

- 8 blade, 640 mm diameter cooling fan with thermostatically controlled viscous clutch. Dual drive belts and thermostats.
- Radiator frontal area: 4,452 cm²
- 23 L coolant capacity.

AIR INTAKE SYSTEM

- Vertical air intake mounted on back of cab. Two stage Donaldson air cleaner with 280 x 380 mm main element and 160 x 350 mm secondary element.
- 540 x 580 mm air-to-air intercooler.

FUEL SYSTEM

- Denso common rail fuel injection. Separate fuel filter and water separator.
- 180 L steel tank.

ENGINE DRIVEN PTO (PTO MODELS ONLY)

- Constant mesh flywheel driven. PTO rotates at 0.7 x engine speed.
- 353 Nm maximum output torque.
- Anti-clockwise rotation when viewed from rear of engine.

CLUTCH

- Air assisted hydraulic control. Single plate 352 mm (FSS), 381 mm (FTS)
- Asbestos free lining material.
- Total lining area: 1,164 cm² (FSS)
1,363 cm² (FTS)

TRANSMISSION

ISUZU MLD-6Q 6 Speed manual

- 6 forward speeds including overdrive, 1 reverse speed.
 - Syncromesh on gears 2-6. Air assisted gearshift.
 - 6.5 L oil capacity.
 - PTO provision on LHS of transmission case. PTO drive from counter gear.
 - Gear ratios (: 1)
- | 1st | 2nd | 3rd | 4th | 5th | 6th | Rev |
|-------|-------|-------|-------|-------|-------|-------|
| 6.720 | 4.244 | 2.580 | 1.540 | 1.000 | 0.763 | 6.823 |

TRANSFER GEARBOX

FSS - ISUZU TF36

- High ratio: 1.00:1, Low ratio: 2.091:1
- Part time 4WD.

FTS - ISUZU TF56

- High ratio: 1.00:1, Low ratio: 1.913:1
- Full time 4WD with driver activated centre differential lock.

SITEC 190
Power : 141 kW / 2,400 RPM
Torque : 582 Nm / 1,500 RPM

SITEC 220
Power : 164 kW / 2,400 RPM
Torque : 668 Nm / 1,500 RPM

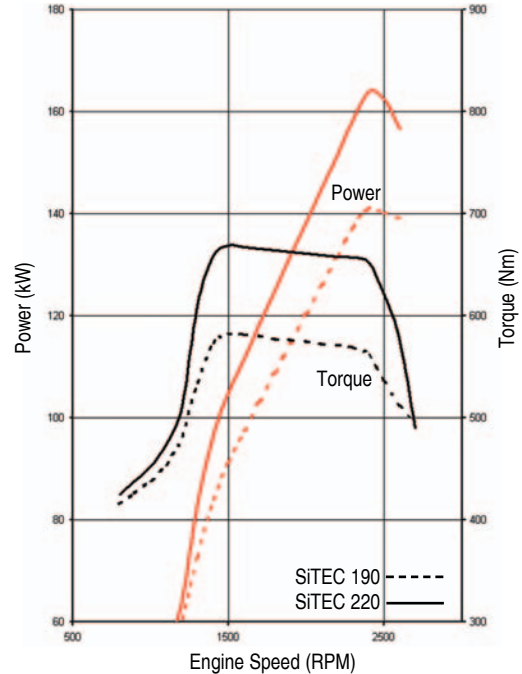

ISUZU SITEC 190 (6HK1-TCN) & SITEC 220 (6HK1-TCC)
ENGINE PERFORMANCE CHART

AXLES

FRONT

ISUZU

- Axle capacity: 3,900 kg (FSS), 4,700 kg (FTS)
- Full floating banjo type. Birfield outer joints, permanently engaged hubs.
- Drive ratio: 5.571:1

REAR

ISUZU

- Axle capacity: 6,500 kg (FSS), 9,200 kg (FTS)
- Full floating banjo type.
- Drive ratio: 5.571:1
- 'No Spin' differential lock

SUSPENSION

FRONT

- Nominal size (mm): 1,350 x 70 (FSS), 1,470 x 80 (FTS)
- Total spring capacity: 4,610 kg (FSS), 5,560 kg (FTS) (at ground)
- Spring type: Multi leaf (FSS), Taper leaf (FTS)
- Single stage alloy steel springs. Fully wrapped eye with greasable shackles.
- Double acting, hydraulic shock absorbers.

REAR

- Nominal size (mm): 1,300 x 70 (FSS), 1,420 x 80 (FTS)
- Total spring capacity: 7,330 kg (FSS), 9,570 kg (FTS) (at ground)
- Two stage, alloy steel, multi-leaf springs. Fully wrapped eye with greasable shackles.

BRAKES

- Air over hydraulic brakes.

- Front drum diameter: 400 mm
- Rear drum diameter: 410 mm
- Swept area: 5853 cm² (FSS), 6497 cm² (FTS)
- Asbestos free lining material.
- Spring type parking brake acting on rear wheels.
- Air controlled exhaust brake.
- 44.8 L total air reservoir capacity.
- Air dryer.

STEERING

- Power assisted recirculating ball steering.

	FSS	FTS
• Gear ratio	16.1-18.8:1	18.1-22.4:1
• Turns lock to lock.	2.8	3.5
• Wheel cut angle (inside wheel)	36°	34°

WHEELS AND TYRES

FSS

- 6.75x22.5 Eight stud wheels.
- 9R22.5 TL 133/131K Michelin XZY Tubeless tyres.
- Maximum tyre rating: 2,060 kg per tyre (single tyres).
1,950 kg per tyre (dual tyres).

FTS

- 7.50x22.5 Eight stud wheels.
- 10R22.5 TL 144/142K Michelin XZY Tubeless tyres.
- Maximum tyre rating: 2,800 kg per tyre (single tyres).
2,650 kg per tyre (dual tyres).
- Frame mounted winch type spare wheel carrier.
Spare wheel and tyre assembly supplied (FSS & FTS).

AXLE LOAD SUMMARY

	FRONT	REAR
FSS 550		
Axle Capacity (kg):	3,900	6,500
Spring Capacity (kg):	4,610	7,330
Tyre Capacity (kg):	4,120	7,800
Limit (kg):	3,900	6,500
FTS 750		
Axle Capacity (kg):	4,700	9,200
Spring Capacity (kg):	5,560	9,570
Tyre Capacity (kg):	5,600	10,600
Legal Limit (kg):	6,000	9,000
Limit (kg):	4,700	9,000

Note: Vehicle loading limit is determined by the combination of axle loading limit, GVM and GCM limit, and government regulatory requirements. Consult your Isuzu dealer to select the correct vehicle for your specific application.

CHASSIS FRAME

- Cold riveted ladder frame with parallel side rails.
- SAPH440 weldable steel (FSS), HT540A weldable high tensile steel (FTS).
- Frame dimensions

	FSS	FTS
Side rail (mm):	229 x 71 x 8.0	253 x 80 x 7.5
Rear frame width (mm):	840	850
- Frame reinforcement section (FTS only).

ELECTRICAL SYSTEM

- 24 Volt electrical system.
- 24 Volt, 60 Amp alternator.
- 24 Volt, 4.5 kW starter motor.
- 2 x 75D23R (520CCA) batteries connected in series.

CABIN SPECIFICATIONS AND APPOINTMENTS

CAB EXTERIOR

- All steel cab, side door impact protection beams. Outer body panels galvanised, corrosion resistant primer treated cab.
- Manual cab tilt to 45°. Access to fluid checkpoints without tilting cab. Lift up front access panel for clutch, windscreen washer fluids and cab air filter screen. Four point silicone filled rubber cab mounting.
- Body coloured steel front bumper with step holes and footplate.
- 90° opening internally reinforced door. Heavy duty aluminium non slip entry steps.
- Tinted, laminated windscreen. 2 speed windscreen wiper system, variable intermittent wipe mode, triple washer jets.
- Halogen headlamps. Park lamps and roof-mounted clearance lamps.
- Combination brake, turn, reverse and marker lamps, registration plate illumination lamps. Extended wiring harness. Reverse alarm.
- 'West Coast' type rear view mirrors. Large flat mirror glass with additional, independently adjustable convex 'spot' mirror on both sides.

CAB INTERIOR

- Isringhausen ISRI 6500/517 air suspension driver's seat, auto weight adjustment to 130 kg. Height, rake and backrest recline adjustment. Pneumatic lumbar support. Outboard reclining passenger bucket seat, centre seat with folding seat back.
- 3-point, lap sash seatbelts with emergency locking belt retractors in all outboard seating positions. Centre lap seatbelt.
- 'A' pillar entry assist grips. Fluorescent dome interior lamp with On/Door/Off switch activated by either door.
- Full interior panel trim, padded roof lining, vinyl floor mats. Windscreen header storage shelf. DIN sized aperture in dash for CB. Overhead console fitted with harness for CB.

- Tilt/Telescopic adjustable steering column, soft feel urethane steering wheel.
- 12 Volt, 100 Watt and 24 Volt, 2 pin accessory sockets located in centre console.
- Electric windows.
- Central locking with remote keyless entry.
- Centre fascia pullout drinks holder. Lockable storage compartment on centre seat back. Cigarette lighter.
- Heater/Demister with 4-speed fan and outlets for windscreen, side windows, face and floor.
- Standard fully integrated air conditioning.
- Two speaker Eurovox Radio/CD player with digital anti skip memory.
- Remote seek/volume and mute switch located on dash to right of steering wheel.
- Optional 10 stack CD player.

DRIVER CONTROLS

- Key-operated engine start/stop and steering lock. Electronic throttle control. Engine idle speed control.
- Left side combination stalk: Windscreen wipers, washers, exhaust brake and hazard lights.
- Right side combination stalk: Turn signals and headlamps.

INSTRUMENTATION

- Gauges: Electronically driven speedometer, odometer, tripmeter, tachometer. Gauges for coolant temperature and brake air pressure.
- Warning lamps: Warning bulb check switch. Battery charge, brake system, engine malfunction, oil pressure, stop and tail lamp failure.
- Indicator lamps: Turn signals, parking brake, high beam, exhaust brake engaged. 4WD Engaged.

FSS 550 4x4 Standard/PTO

8FN02-9A0 (MU1) 8FN02-9A2 (MU1)

FTS 750 4x4 Standard/PTO

8FP02-9C0 (MU1) 8FP02-9C2 (MU1)

PERFORMANCE (Calculated)

	FSS 550	FTS 750
Max Geared speed:	113 km/h @ 2,650 rpm	117* km/h @ 2,650 rpm
Gradeability (lowest gear):	84% at 10,000 kg GVM	64% at 13,000 kg GVM
Gradeability (top gear at 100 km/h):	1.6% (tray body at 10,000 kg GVM)	1.3% (tray body at 13,000 kg GVM)
Engine speed (top gear at 100 km/h):	2,395 rpm	2,275 rpm

Performance figures quoted are representative only and based on typical dimensions, body styles and weights. Please consult your Isuzu dealer for an estimation based on your specific application. * Road speed limited to 100 km/h

MODEL RATINGS AND DIMENSIONS

MODELS	RATINGS (kg)		TARE MASS [#] (kg)			DIMENSIONS (mm)											TURN CIRCLE	
	GVM	GCM	TOTAL	FRONT	REAR	WB	OAL	FOH	ROH	CA	CE	RT	ORT	CH	CW	FFH		RFH
																UNLADEN	UNLADEN	TO KERB
FSS	10,000	15,000	4,130	2,690	1,440	3,700	6,635	1,330	1,605	2,990	4,595	1,680	2,195	2,785	2,265	950	1,065	15.2m
FTS	13,000	20,500(1) 18,000(2)	4,780	3,000	1,780	4,250	7,480	1,330	1,900	3,535	5,435	1,790	2,360	2,945	2,390	1,090	1,160	17.7m

Estimated mass of cab/chassis with oil, water and fuel tank containing 10 litres of fuel and excluding spare wheel and tools. (1) on road, (2) off road.

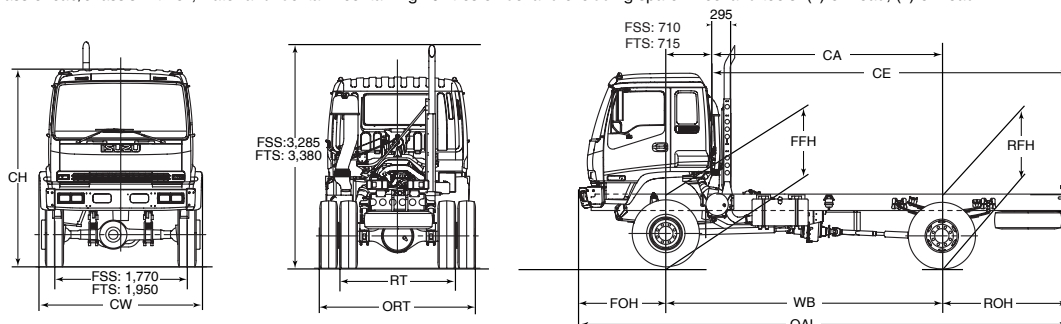

For further information regarding Cab/Chassis dimensions your Isuzu Dealer can access detailed Body Builders diagrams from the Isuzu Truck Technical Reference CD.

ISUZU NEW TRUCK WARRANTIES

STANDARD TRUCKPOWER WARRANTY*			TRUCKPOWER EXTENDED WARRANTY OPTIONS [#]		
NEW VEHICLE	3 years	150,000 km	4 years / 250,000 km	5 years / 300,000 km	6 years / 350,000 km
DRIVETRAIN	3 years	150,000 km			
CAB CORROSION	3 years	unlimited			

Why have Isuzu Trucks been Australia's No. 1 choice since 1989? *

- Widest range of models to suit most applications
- Premium componentry and Isuzu diesel engines
- Network of over 40 specialist Isuzu Dealerships and branches
- Sales, services and parts support
- Predictable operating costs through Dealer ISIS program
- Factory and range of extended warranties available
- High resale values
- Leading reputation for reliability

www.isuzu.com.au

* Source Truck Tracker 2003

* Subject to the conditions outlined in the I-GM New Vehicle Warranty, the Isuzu FSS & FTS models carry a standard factory warranty which covers the owner: (i) for the entire vehicle, for the first 36 months or 150,000 km (whichever comes first). (ii) for the drivetrain, which runs concurrently, for 36 months or 150,000 km (whichever comes first). (iii) against cab corrosion, for 36 months and unlimited kilometres.

A TruckPower Extended Warranty as illustrated is available by purchase to cover the owner against the failure of original components, but excludes some components and expendable items such as oil, filters, etc. Please consult with your Isuzu Dealer for full details obtained from a dedicated brochure available to customers.

ISUZU-GENERAL MOTORS AUSTRALIA LTD A.C.N. 006 962 572. PLEASE NOTE: as the policy of I-GM is one of continual product improvement, all specifications and equipment are subject to change without notice. No I-GM dealer or other person is authorised or permitted to give or make any statement, assertion or undertaking in relation to the quality, performance, characteristics, descriptions or fitness for any purpose of any I-GM product or in connection with the supply of any I-GM product which is at variance with any written statement, assertion or undertaking on any of these subjects given or made by I-GM in its published sales literature, and the company accepts no liability for any such unauthorised action. I-GM has franchised dealers in many parts of Australia, for the sale of service, parts and the provision of service to the owners of I-GM products. Every endeavour is made to ensure that such dealers carry adequate stocks of service parts and are equipped to provide satisfactory service, but makes no promise, other than that contained in the I-GM new vehicle warranty, that such parts or service facilities will be available or available at any specific location or at any particular time. A word about this specification sheet. We have tried to make it as comprehensive and factual as possible. However, since the time of printing some of the information you will find here may have been updated. Also, some of the equipment shown or described through this specification sheet may have been changed and/or is available at extra cost. And the right is reserved to make changes at any time without notice, in prices, colours, materials, equipment and models. Your I-GM dealer has details and before ordering, you should ask him/her to bring you up to date.

OCTOBER 2004. ARK/GM 0135

ISUZU

RELIABILITY IS EVERYTHING