

550

FSR 550 LONG

GVM: 9500kg
GCM: 15,000kg
WHEELBASE: 4,800mm

ISUZU 6HE1 ENGINE PERFORMANCE

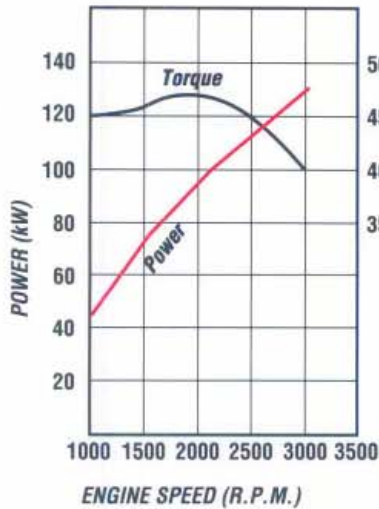

- Type: 6 cylinder, overhead camshaft diesel, four stroke, direct injection.
- Bore x Stroke 110 X 125 mm
- Displacement 7127 cc
- Compression Ratio 17.0:1
- Output-Power 129 kW @ 3000 rpm (DIN Nett)
- Torque 471 Nm @ 1800 rpm (DIN Nett)

DIMENSIONS AND WEIGHTS

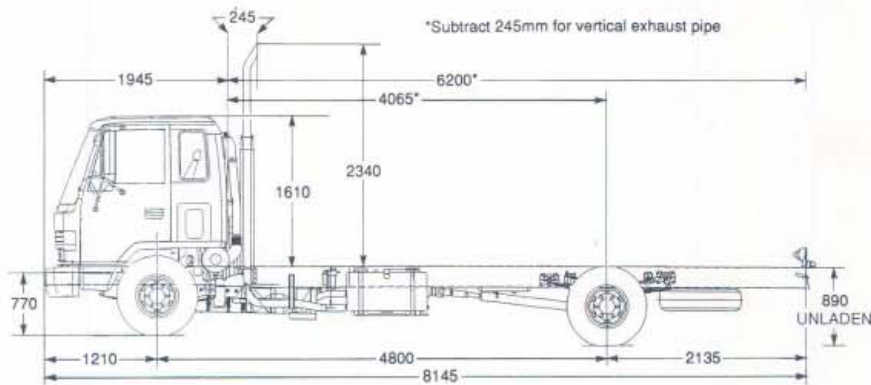

*ESTIMATED KERB MASS (kg)	
FRONT	2185
REAR	1165
TOTAL	3350
FRAME WIDTH (mm)	
	800
TURNING CIRCLE (m)	
Kerb to Kerb	15.1
BODY LENGTH (mm)	
	6100
Subject to weight distribution	

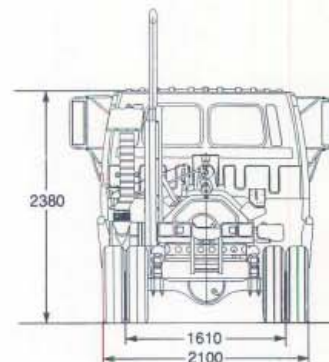

*Chassis and cab with oil, water and fuel tank containing 10 litres of fuel.

ISUZU-GENERAL MOTORS AUSTRALIA LTD A.C.N. 006 962 572

12/50 WARRANTY. Every Isuzu Truck is covered by the I-GM new vehicle warranty which covers your vehicle for the first 12 months or 50,000 kilometres.
 PLEASE NOTE: as the policy of Isuzu-General Motors Australia Motors is one of continual product improvement, all specifications and equipment are subject to change without notice. Body illustrated are not standard. No I-GM dealer or other person is authorised or permitted to give or make any statement, assertion or undertaking in relation to the quality performance characteristics descriptions or fitness for any purpose of any I-GM product or in connection with the supply of any I-GM product which is at variance with any written statement assertion or undertaking on any of these subjects given or made by Isuzu-General Motors Australia Limited in its published sales literature, and the company accepts no liability for any such unauthorised action. Isuzu-General Motors Australia Limited has franchised dealers in many parts of Australia. For the sale of service parts and the provision of service to owners of I-GM products. Every endeavour is made to ensure that such dealers carry adequate stocks of service parts, and are equipped to provide satisfactory service, but makes no promise, other than that contained in the New Vehicle Warranty given by Isuzu-General Motors Australia Limited, that such parts or service facilities will be available, or available at any specific location or any particular time.

ISUZU





550

FSR 550 LONG

ORDERING CODE:
8FF02-311

ENGINE - ISUZU 6HE1

Lubrication:

- Pressure feed lubrication with full flow paper element and partial flow sub filter. Plate type oil cooler in water jacket. Oil capacity 15 litres including filter.

Cooling System:

- Six blade plastic cooling fan, size 470 mm diameter with thermatic fan clutch.
- Tube and corrugated fin pressure type radiator with bell mouth fan shroud. Size (mm) 622 h x 559 w x 53 t. Frontal area 0.348 m².
- Coolant capacity 19.0 litres.

FUEL SYSTEM

- Two stage paper element air cleaner, Donaldson 11" with vertical air intake stack and rain head.
- In line plunger, Bosch 'A' type fuel injection pump with mechanical all speed governor.
- In line paper filter, see through water separator with drain cock.
- Fuel tank capacity 200 litres.
- Horizontal exhaust muffler with vertical exhaust stack.

CLUTCH

- Hydraulic control dry single plate with coil type cushioning springs. 350 mm (14") diameter. Lining area 1164 cm² (each side).
- Asbestos free lining material.

TRANSMISSION - ISUZU MBG6P

- Six speed overdrive, constant mesh, synchromesh on gears 2-6. Oil capacity 6.1 litres.
- **Gear Ratios:1**

1st	6.378
2nd	3.627
3rd	2.239
4th	1.452
5th	1.000
6th	0.787
Reverse	5.835
- Maximum geared speed 114 km/h
- Two piece propeller shaft, 90 mm diameter
Length:
1st section 1348 mm
2nd section 1267.5 mm

REAR AXLE - CAPACITY 7,700kg

- Banjo type, fully floating, single reduction. Ratio 5.125:1
- Hypoid type ring gear, 343 mm diameter
Oil capacity 5.5 litres

REAR SUSPENSION

- Semi-elliptical, alloy steel tapered multi leaf springs. Fully wrapped eye with greasable shackles.
- Size - length x width x thickness; No. leaves. Main: 1300 x 70 x 11 mm - 8 leaves
- Auxiliary: 850 x 70 x 10 mm - 7 leaves

FRONT AXLE CAPACITY - 3,600kg

- Reverse Elliot I-beam type. King pin diameter 35 mm with cylindrical roller thrust bearing.

FRONT SUSPENSION

- Semi-elliptical, alloy steel tapered multi-leaf springs. Fully wrapped eye with greasable shackles.
- Size - length x width x thickness; No leaves. 1200 x 70 x 10 mm - 8 leaves
- Hydraulic, double acting, telescopic shock absorbers.

STEERING

- Fully integral power assisted recirculating ball type. Gear ratio 16.1-18.8:1 Turns lock to lock 4.6.
- Gear driven vane type oil pump, oil capacity 2.0 litres.

BRAKES

- Air over hydraulic dual circuit, front two leading, rear dual two leading. Drum diameter front and rear 320 mm. Total swept area 5124.6 cm².
- Asbestos free lining material.
- Spring park brake acting on rear wheels.
- Butterfly, air controlled exhaust brake system. Activation switch on wiper/washer control stalk.

CHASSIS FRAME

- Parallel rail, ladder type, channel section, cold rivetted.
- Side member dimensions 225 x 70 x 6 mm
- Frame reinforcement 180 x 4.5 mm at back of cab.
- High tensile steel, HT 55 weldable frame material.

WHEELS AND TYRES

- 6.00GS x 16 - 6 stud disc wheel, 20 mm bolt size.
- 8.25 R 16 LT - 14 ply radial Tyres front and rear.
- Number of tyres 7, including spare.
- Winch type spare wheel carrier.

ELECTRICAL SYSTEM

- Batteries - 2 x 12 volt - 53 amp/h, negative earth.
- Alternator 24 Volt - 40 amp.
- Starter motor 24 Volt - 4.5kW output.
- Rear stop and tail lamps and licence plate lamp with long leads for variable body mounting. Turn signal side indicator lamps for body mounting.

CAB EXTERIOR

- All steel cab, manual tilt to 45°, cation electro deposition primer, torsion bar counter balanced.
- Heavy duty bumper bar with four rectangular halogen headlamps inset.
- Combination turn signal and park lamps.
- Laminated windshield, 2 speed wiper/washer with intermittent mode.
- Front and rear quarter vent windows.
- West Coast type rear mirrors with clearance lamps.
- Corrosion resistant non slip cab entry steps.
- Access to engine fluid checks without tilting cab.
- Tool kit with 7000 kg capacity jack.

CAB INTERIOR

- Fully trimmed cab interior with cloth seat facings, formed roof lining and overhead parcel shelf with driver and passenger sun visors.
- ISRI 5000 drivers seat with mechanical suspension and lumbar support, adjustment for seat back recline, seat slide and height control.
- Outboard passenger seat, folding centre seat back with lockable compartment and snack tray.
- Outboard lap/sash seat belts with emergency locking retractors, inboard lap seat belt.
- Tilt telescopic adjustable steering column, soft feel urethane steering wheel.
- Easy entry grab handles on 'A' and 'B' pillars.
- Heater demister with 4 speed fan, 4 outlet vents to screen, 5 fascia outlets, 5 foot outlets.
- AM/FM radio with digital clock dash mounted.

INSTRUMENTATION

- Speedometer, odometer and tachometer.
- Gauges for coolant temperature, fuel level and brake air pressure.
- Dash illumination control.

INDICATOR LAMPS

- Turn signals, parking brake on, high beam on, exhaust brake engaged, brake fluid level.

WARNING LAMPS

- With warning bulb check switch.
- Battery charge, oil filter clogged, oil pressure, low air pressure, brake system, air cleaner clogged, stop and tail lamp failure.

SWITCHES

- Left side combination switch for exhaust brake, wipers and washer.
- Right side combination switch for headlamps, turn signals and headlamp dip.
- Hazard lamp switch.
- Key operation for engine stop and start, external engine crank switch for service when cab tilted.
- Three way switch for interior lamp activated by driver and passenger doors.
- 24 volt 2 pin accessory plug on centre fascia panel.