

ISUZU

FTR800 LONG



ENGINE ISUZU 6HH1-S

- Type:** 6 cylinder, overhead camshaft, 4 stroke, direct injection, diesel.
- Bore x Stroke:** 115 mm x 132 mm.
- Displacement:** 8226 cc.
- Compression Ratio:** 18.5 : 1.
- Output - Power:** 150 kW @ 2850 RPM. (ISO 1585)
- Torque:** 539 Nm @ 1700 RPM. (ISO 1585)

COOLING SYSTEM

- 6 blade plastic cooling fan 500 mm diameter with thermatic fan clutch.
- Corrugated fin radiator with fan shroud. Frontal area 3820 cm². Coolant capacity 23.3 litres.

CLUTCH

- Hydraulic control dry single plate. 355 mm (14") diameter.
- Asbestos free lining material. Total lining area (both sides) 1164 cm².

TRANSMISSION: ISUZU MLD6E

- 6 speed direct drive, constant mesh with synchromesh on gears 2-6. Oil capacity 6.5 litres.
 - Gear ratios (: 1)
- | | | | | | | |
|-------|-------|-------|-------|-------|-------|-------|
| 1st | 2nd | 3rd | 4th | 5th | 6th | Rev |
| 8.181 | 5.167 | 3.333 | 2.105 | 1.347 | 1.000 | 8.307 |
- Maximum geared speed 96km/h.
 - 3 piece propeller shaft, 90 mm diameter.

REAR AXLE: ISUZU R092 CAPACITY 9200 KG

- Banjo type, fully floating, single reduction. Ratio 5.57 : 1.
- Hypoid type ring gear. 398 mm diameter. Oil capacity 8.0 litres.

FRONT AXLE: ISUZU F054 CAPACITY 5400 KG

- Reverse Elliot I-beam type. King pin diameter 45 mm with cylindrical roller thrust bearing.

BRAKES

- Air over hydraulic, dual circuit, front and rear leading and trailing shoes. Drum diameter front and rear 410 mm. Total swept area 7214 cm².
- Air dryer.
- Asbestos free lining material.
- Spring park brake acting on rear wheels.

AIR INTAKE SYSTEM

- Donaldson 11" two stage with vertical air intake stack and rain head.

ELECTRICAL SYSTEM

- Batteries - 2 x 12 volt / 65 amp/h, negative earth.
- Alternator - 24 volt / 40 amp.
- Starter motor - 24 volt / 4.5 kW.
- Rear stop and tail lamps and licence plate lamp with long leads for variable body mounting.

EXHAUST SYSTEM

- Horizontal exhaust muffler with vertical exhaust stack.
- Exhaust brake, air controlled.

FUEL SYSTEM

- In line plunger, Bosch 'ADS' type fuel injection pump with mechanical all speed governor. In line filter, see through water separator with drain cock. Single fuel tank, capacity 180 litres.

STEERING

- Fully integral, power assisted, recirculating ball type.
- Gear ratio 22.4 : 1. Turns lock to lock 4.8.
- Gear driven vane type oil pump. Oil capacity 2.5 litres.

SUSPENSION

FRONT

- Semi-elliptical, alloy steel tapered multi-leaf springs. Fully wrapped eye with greaseable shackles.
- **Length x Width x Thickness x No. leaves**
1470 mm x 80 mm x 12 mm x 2
80 mm x 13 mm x 6
- Hydraulic, double acting, telescopic shock absorbers.

REAR

- Semi-elliptical, alloy steel tapered multi-leaf springs. Fully wrapped eye with greaseable shackles.
- **Length x Width x Thickness x No. leaves**
Main : 1420 mm x 80 mm x 13 mm x 3
80 mm x 14 mm x 4
Aux : 1000 mm x 80 mm x 13 mm x 3
80 mm x 14 mm x 3

WHEELS AND TYRES

WHEELS

- 7.50 x 22.5, 10 stud disc wheels, 10R22.5 tubeless tyres front and rear.

TYRES

- Number of wheels and tyres 7, including spare.

CHASSIS FRAME

- Parallel rail, ladder type channel section, cold rivetted.
- Straight frame for easy body mounting. Frame width 850 mm.
- Side member dimensions 254 mm x 85 mm x 8 mm.
- Frame reinforcement angle section 224 mm x 77 mm x 4.5 mm.
- Material HT540A weldable high tensile steel.

ISUZU GENERAL MOTORS AUSTRALIA LTD A.C.N. 006 982 572 24/100,000 WARRANTY. Subject to the conditions of the I-GM New Vehicle Warrant, every Isuzu Truck carries a warranty which covers your vehicle for the first 24 months or 180,000 kms (whichever comes first). A 36 months or 150,000 kms (whichever comes first), power train warranty runs concurrently with the new vehicle warranty, as does a 36 months unlimited kilometres cab corrosion warranty. PLEASE NOTE: as the policy of I-GM is one of continual product improvement, all specifications and equipment are subject to change without notice. Any body illustrated is not standard equipment. No I-GM dealer or other person is authorised or permitted to give or make any statement, assertion or undertaking in relation to the quality, performance, characteristics, descriptions or fitness for any purpose of any I-GM product or its connection with the supply of any I-GM product which is at variance with any written statement, assertion or undertaking on any of these subjects given or made by I-GM in its published sales literature, and the company accepts no liability for any such unauthorised action. I-GM has franchised dealers in many parts of Australia, for the sale of service, parts and the provision of service to the owners of I-GM products. Every endeavour is made to ensure that such dealers carry adequate stocks of service parts and are equipped to provide satisfactory service, but makes no promise, other than that contained in the I-GM new vehicle warranty, that such parts or service facilities will be available or available at any specific location or at any particular time. A word about this specification sheet. We have tried to make it as comprehensive and factual as possible. However, since the time of printing some of the information you will find here may have been updated. Also, some of the equipment shown or described through this specification sheet may have been changed and/or is available at extra cost. And the right is reserved to make changes at any time without notice, in prices, colours, materials, equipment and models. Your I-GM dealer has details and before ordering, you should ask him/her to bring you up to date.

LUBRICATION SYSTEM

- Pressure feed lubrication with combination full flow and partial flow by-pass filter. Plate type oil cooler in water jacket. Oil capacity 13.5 litres including filter.

CAB EXTERIOR

- All steel cab with welded strengthening ribs and side door impact beams. Torsion bar assisted manual tilt to 45°.
- 4 silicon filled rubber cab isolators.
- Cation electrodeposition primer.
- Bumper bar with step holes and footplate.
- Halogen headlamps, hinged for easy bulb replacement. Park lamps and cab clearance lamps.
- Turn signal lamps in front bumper and over wheel arches.
- 2 speed wiper/washer with variable intermittent mode. Triple washer jets mounted on wiper arms.
- Tinted, laminated windscreen; tinted, toughened side and rear glass.
- West Coast type rear view mirrors.
- Alloy non-slip cab entry steps.
- Lift up front access panel for clutch and windscreen washer fluids, cab air filter screen. Engine and brake fluid check points at rear of cab.

CAB INTERIOR

- Fully trimmed cab interior with cloth seat facings, formed roof lining. Overhead storage lockers. Driver and passenger sun visors.
- Centre storage compartment with lockable lid/tray.
- Pull out drinks holder in centre fascia, cigarette lighter with ash trays in doors.
- Driver's seat with mechanical suspension and 3 way lumbar support. Adjustment for seat back recline, seat slide and weight control.
- Outboard reclining passenger seat.
- Lap/sash seat belts with emergency locking retractors.
- Tilt/telescopic adjustable steering column, soft feel urethane steering wheel.
- Easy entry grab handles on 'A' and 'B' pillars.
- Heater demister with 4 speed fan, 4 outlet vents to screen, 5 fascia outlets, 5 foot outlets, demister ducts to door glass.
- AM/FM radio cassette with digital clock, dash mounted.
- DIN standard aperture in dash for CB radio.
- Park brake activation lever at left side of driver's seat.
- Rear vision mirror.
- Passenger side assist grip.
- Driver's left foot rest.
- Cab exhaust vents rear/upper cab.
- Business card clip. Coat hook at rear of cab.
- Elastic mesh pocket on driver's door.

CONTROLS

- Left side combination stalk switch for exhaust brake, windscreen wipers and washer, hazard lamps.
- Right side combination stalk switch for headlamps, high beam and turn signals.
- Engine idle speed adjust control.

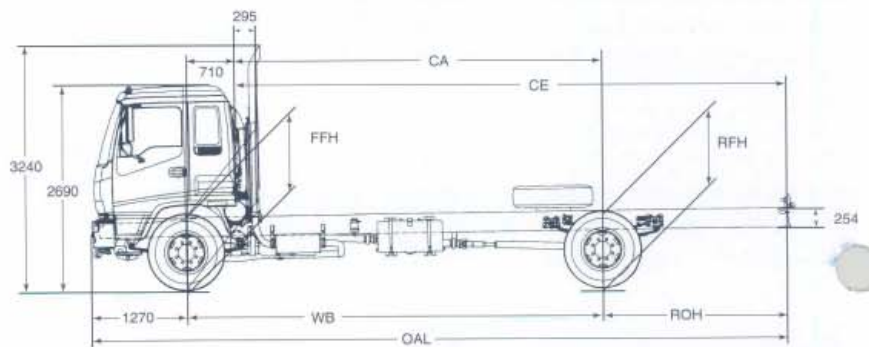
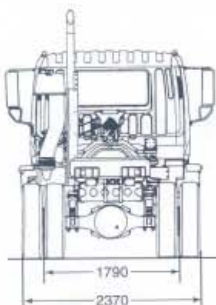

- Key operation for engine start and stop, external engine crank switch for service when cab is tilted.
- 3 way switch for interior lamp activated by driver and passenger doors.
- 24 volt-2 pin accessory plug in centre console.

INSTRUMENTATION

- GAUGES: Speedometer, odometer, trip meter and tachometer. Gauges for coolant temperature, fuel level and brake air pressure.
- WARNING LAMPS: With warning bulb check switch. Battery charge, oil pressure, low air pressure, brake system, stop and tail light failure.
- INDICATOR LAMPS: Turn signals, parking brake on, high beam on, exhaust brake engaged. Reversing lamp and beeper.

TOOLS

- Lockable tool box with 10000 kg capacity jack and wheel changing tools, tool kit.

MODELS, CODES & RATINGS

MODEL	WHEELBASE	GVM	GCM	ORDERING CODE
FTR 800 LONG	5550mm	14150kg	20500kg	8FM02-871

KERB MASS (kg)*

	Front	Rear	Total
FTR 800 LONG	2,650	1,605	4,255

*Estimated mass of chassis cab with oil, water and fuel tank containing 10 litres of fuel. Excluding spare wheel and tools.

DIMENSIONS (mm) *

	FTR 800 LONG
WB Wheelbase	5,550
OAL Overall Length	9,270
ROH Rear Overhang	2,450
CA Cab To Axle	4,840
CE Cab To End Of Frame	7,290
FFH Front Frame Height, Unladen	945
FFH Front Frame Height, Laden	908
RFH Rear Frame Height, Unladen	1,000
RFH Rear Frame Height, Laden	935
Turning Circle (Kerb To Kerb)	19.2m
Nominal Max. Body Length*	7,725

*Except Turning Circle: metres. *Subject to weight distribution

FTR800 LONG

ISUZU

RELIABILITY IS EVERYTHING