

ISUZU

SPECIFICATIONS

NLR 45-150 TIPPER



AUSTRALIA'S TOP SELLING TRUCK BRAND SINCE 1989.

AT A GLANCE

GVM	4,500 kg
GCM	7,000 kg
Power	110 kW @ 2,800 rpm
Torque	375 Nm @ 1,600 - 2,800 rpm

UPGRADE OPTIONS

AMT Pack:

Automated Manual Transmission (AMT)

ADVANCED TECHNOLOGY

Emissions: Euro V / ADR 80/03
Meets EEV emissions standard
Driver and passenger airbag with seatbelt pretensioner
ECE-R29 compliant cab
Anti-lock Braking System (ABS)
Stability Control System (IESC)

Anti Skid Regulator (ASR)
Hill Assist - except AMT pack
Electric mirrors
Independent front coil suspension
Cornering lamps



We
share
the
load.

ISUZU
RELIABILITY IS EVERYTHING

NLR 45-150 TIPPER

DRIVELINE AND CHASSIS SPECIFICATIONS

ENGINE: ISUZU 4JJ1-TCS

Type: 4 cylinder 16 valve with chain driven DOHC
Displacement: 2,999 cc
Compression ratio: 17.5:1
Bore x Stroke: 95.4 mm x 104.9 mm
Max power (DIN-NET): 110 kW (148 HP) @ 2,800 RPM
(JIS Gross): 114 kW (153 HP) @ 2,800 RPM
Max torque (DIN-NET): 375 Nm (277 lb.ft) @ 1,600 - 2,800 RPM
(JIS Gross): 388 Nm (286 lb.ft) @ 1,600 - 2,800 RPM
Induction system: Electronically controlled variable nozzle turbocharger with air-to-air intercooler.
Fuel injection: Direct injection high pressure common rail system.
Emission control system: Cooled EGR with exhaust Diesel Particulate Diffuser (DPD). ADR 80/03 (Euro V) compliant. EEV compliant.

CLUTCH

Standard model:

- Auto adjusting hydraulic control with vacuum assistance. Single plate 300 mm diameter.
- Total lining area: 847 cm²

AMT Pack:

- Fully automated, hydraulically controlled, wet clutch and fluid coupling with lock up.

TRANSMISSION

Standard model:

ISUZU MYY-5T

- 5 speed manual. Syncromesh on gears 1-5.
- **Gear ratios (:1)**

1st	2nd	3rd	4th	5th	Rev
5.315	3.053	1.655	1.000	0.721	5.068

AMT Pack:

ISUZU MYY-6S

- 6 speed Automated Manual Transmission (AMT) with both fully automatic and clutchless manual operation modes.
- **Gear ratios (:1)**

1st	2nd	3rd	4th	5th	6th	Rev
5.979	3.434	1.862	1.297	1.000	0.750	5.701

AXLES

Front: Isuzu FI026

- Fully independent wishbone. 2,600 kg capacity.

Rear: Isuzu R050

- Full floating Banjo type. Four differential pinions. 5,000 kg capacity.
- Drive ratio: 4.556:1 (Standard model), 4.100:1 (AMT pack).

SUSPENSION

Front:

- Coil springs.
- Double acting hydraulic shock absorbers.

Rear:

- Taper leaf main, taper leaf helper spring.
- Double acting hydraulic shock absorbers.

BRAKES

- Auto adjusting front and rear disc brakes with dual circuit hydraulic control, vacuum assistance and electronic brake force distribution (EBD).
- ABS, ASR traction control, IESC stability control.

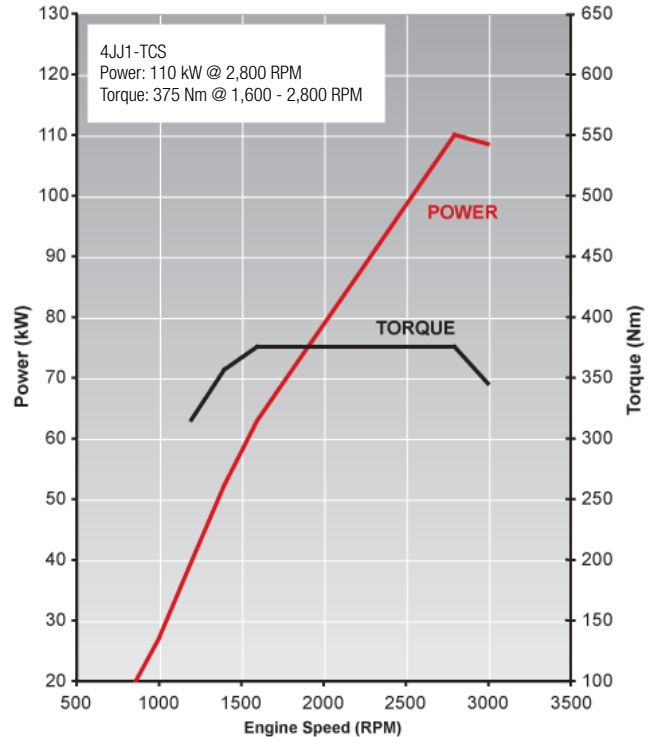

- Hill Assist - except AMT pack.
- Front disc diameter: 293 mm
- Rear disc diameter: 275 mm
- 190 mm diameter drum park brake mounted on rear of transmission.
- Vacuum controlled exhaust brake.

STEERING

- Power assisted rack and pinion.
- Turns lock to lock: 4.2
- Maximum angle: 38° (inside wheel) / 34° (outside wheel)

WHEELS AND TYRES

- 16 x 5.5J five stud steel wheels.
- 195/75R16C 107/105R Michelin Agilis Tubeless.
- Maximum tyre rating
 - Steer axle: 1,950 kg
 - Drive axle: 3,700 kg
- 1 frame mounted spare wheel and tyre assembly.

CHASSIS FRAME

- Cold rivetted ladder frame. SAPH440 weldable steel sidemembers.
- Frame dimensions:
 - Side rail (mm): 180 x 65 x 4.0
 - Rear frame width (mm): 700

TIPPER BODY

- All steel body with drop sides. Auto release two-way tailgate.
- Auto release body lockdown hook.
- Shovel rack. LHS and RHS rope rails. Non-slip side steps.
- 20 second raise / 20 second lower time.
- Cubic volume: 2.0 m³
- Deck plate thickness: 3.2 mm
- Side / front / tail plate thickness: 2.3 mm

FUEL TANK

- Frame mounted 75L steel fuel tank.
- Lockable fuel cap.

ELECTRICAL SYSTEM

- 24 volt electrical system.
- 90 amp alternator.
- 4.0 kW starter motor.
- 2 x 80D26L (630 CCA) batteries connected in series.

CABIN SPECIFICATIONS AND APPOINTMENTS

CAB EXTERIOR

- All steel construction. High tensile steel used for cab underframe. Manual cab tilt to 45° with torsion bar assistance.
- Complies with ECE-R29 cab strength standard.
- Heavy duty non slip entry steps.
- 90° opening internally reinforced front doors.
- Water spray suppression guards and front mudflaps.
- Laminated windscreen with shade band.
- Two speed windscreen wipers with intermittent wipe mode.
- Halogen multi-reflector headlamps incorporating turn signals. Additional door mounted integrated side indicator/cornering lamps.
- Combination brake, turn, reverse and marker lamps, registration plate illumination lamps. Reverse alarm.
- Heated and powered exterior main mirrors with flat glass and additional independently adjustable convex “spot” mirrors.
- Body coloured grille.
- Body coloured impact resisting polycarbonate bumper with steel backing frame.

CAB INTERIOR

- Contoured adjustable driver's bucket seat.
- Front passenger bench seat with 2 seat capacity.
- 3-point lap sash seatbelts in all outboard seating positions. Driver and outboard front passenger seatbelts fitted with pretensioner. Centre seat lap belts.
- Driver and outboard front passenger airbag.
- **AMT Pack:** Driver's footrest.
- Door and roof pillar entry assist grips.
- Full interior trim, padded roof lining and vinyl floor covering. Driver and passenger windscreen header storage shelf.
- Tilt/Telescopic adjustable steering column, soft feel urethane steering wheel.
- Electric windows.
- Central locking with remote keyless entry and immobiliser.
- Twin cup holders. 24V cigarette lighter. Dashboard hook.
- Front door mounted storage pockets and driver's side ashtray.
- Fully integrated air conditioning and heater/demister with 4-speed fan and outlets for windscreen, side windows, face and floor.
- Fluorescent type interior lamp with On/Door/Off switch.
- 2 DIN, two speaker radio/CD/DVD Digital Audio Visual Entertainment (DAVE) unit with 6.2" LCD touch screen. DAB+ digital radio and fully integrated Bluetooth with voice recognition. 4GB internal storage for music files. USB/SD card and auxiliary input connection provisions.
- DIN sized compartment for storage or for CB radio installation.

DRIVER CONTROLS

- Key-operated engine start/stop and steering lock. Engine idle speed control.
- Hill Assist slow/fast engagement control and on/off switch - except AMT pack.
- ASR and IESC on/off.
- DPD regeneration.
- **AMT Pack:** AMT slow/fast gear engagement control. 1st gear start and normal/economy gear selection modes.
- **Left side combination stalk:** Windscreen wipers, washers and exhaust brake.
- **Right side combination stalk:** Turn signals and headlamps.
- Tip body raise and lower lever with safety release mechanism.

INSTRUMENTATION

- Electronically driven speedometer and tachometer. Digital odometer with integrated dual tripmeter. Engine coolant temperature and fuel level gauges.
- Warning lamps: Check engine, oil pressure, ABS, SRS airbag, alternator charge, service brakes, park brake, seatbelt unfastened, low fuel level.
AMT pack: Check AMT.
- Indicator lamps: Hill Assist (except AMT pack), warm up system, high beam, ASR, IESC, DPD status, exhaust brake, turn signals, PTO engaged.
AMT Pack: Econo-mode, 1st gear start.
- **AMT Pack:** Gear selection display

OPTIONS AND GENUINE ACCESSORIES

Include the following (extra cost, request a brochure and further details from your Isuzu dealer):

Digital Audio Visual Entertainment unit:

- Isuzu satellite navigation including three years of free updates.
- Tyre pressure monitoring system.
- Cables for full iPod/iPhone/iPad compatibility and connection to other external audio visual devices.

Other:

- Airbag compatible bullbar.
- 2,500kg rated towbar.

ISUZU CARE

Isuzu Care gives truck owners access to products and services including Roadside Assist, Service Agreements, Extended Care, Extended Isuzu Assist and the Isuzu Care Centre. Call 1800 035 640.

WEIGHTS (kg)

Models	Ratings*		Loading Limit* (at ground)		Cab Chassis Weight #		
	GVM	GCM	Front	Rear	Front	Rear	Total
NLR 45-150 TIPPER	4,500	7,000	1,950	3,700	1515	1210	2725
NLR 45-150 AMT TIPPER	4,500	7,000	1,950	3,700	1535	1230	2765

* Vehicle ratings and front/rear weight limits are subject to government regulatory requirements and weight distribution analysis. Consult your Isuzu dealer to select the correct vehicle for your specific application. # Cab chassis only as supplied and including 10 litres of fuel.

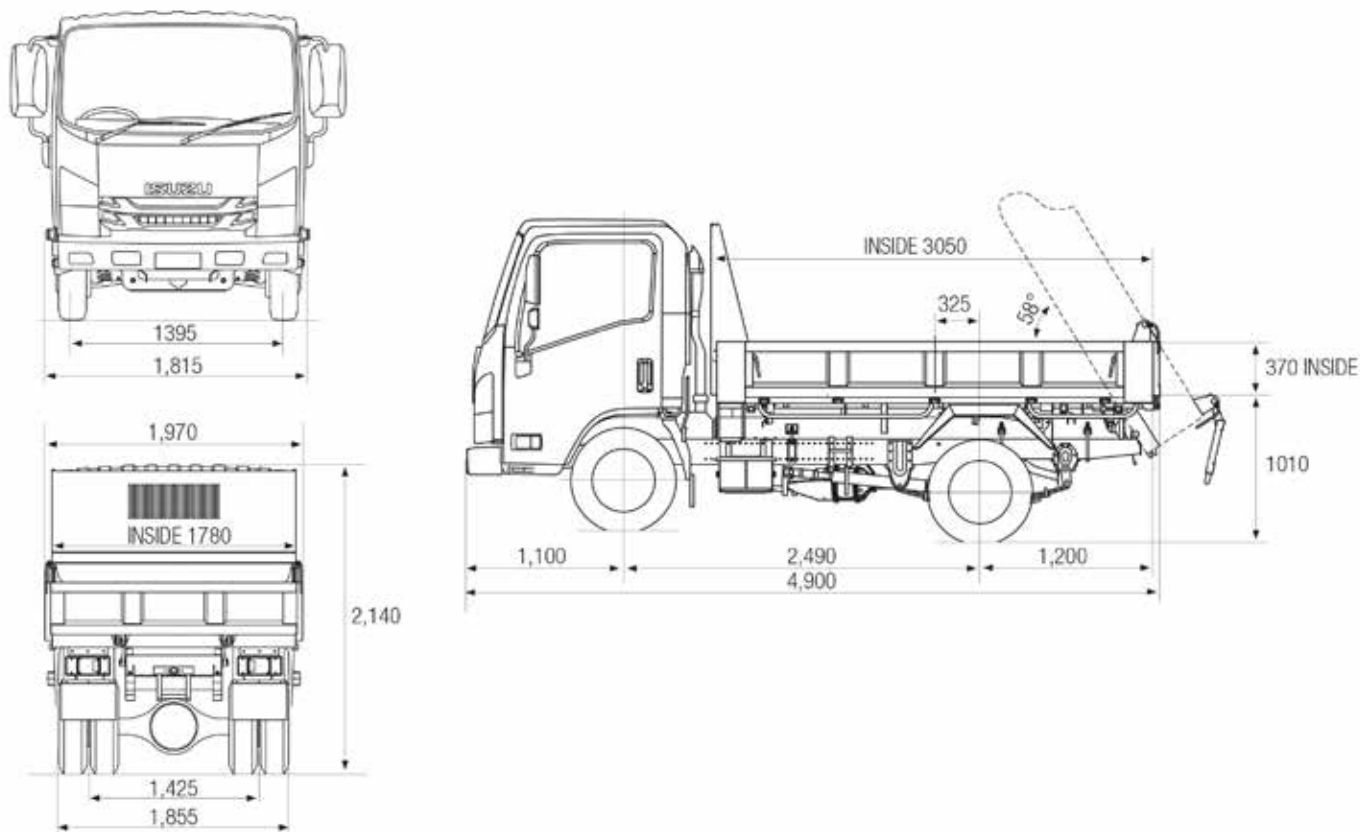

PERFORMANCE (calculated - typical paved road)

		Geared Speed* (top gear at peak power engine RPM)	Low Speed Gradeability (lowest forward gear assuming no wheel slip)	Engine Speed (top gear at 100km/h)
NLR 45-150 TIPPER	At 4,500 kg GVM	108 km/h @ 2,800 RPM	55%	2,590 RPM
NLR 45-150 AMT TIPPER	At 4,500kg GVM	116 km/h @ 2,800 RPM	56%	2,425 RPM

*Maximum speed achievable depends on vehicle frontal area as well as other factors. Consult your Isuzu dealer for more detailed information.

ISUZU WARRANTIES

STANDARD¹

New Vehicle 3 years • 100,000km • 2,000 hours

Isuzu Assist: 24 hour roadside assistance (3 years, unlimited km)*

EXTENDED CARE²

Extended Warranty: 5 years • 250,000km • 4,500 hours

Isuzu Assist: 24 hour roadside assistance (5 years, unlimited km)

ORDER CODES

Model	Code
NLR 45-150 TIPPER	NH-NLRBA-A15
NLR 45-150 AMT TIPPER	NH-NLRBA-Z15

¹ Subject to the conditions outlined in the IAL New Vehicle Warranty, the Isuzu NLR model carries a standard factory warranty which covers the owner: (i) for the entire vehicle, for the first 36 months or 100,000 km or 2,000 hrs (whichever comes first). (ii) against cab perforation corrosion, for 36 months and unlimited kilometres. ² Extended Warranty as illustrated may be purchased to cover the owner against the failure of original components, but may exclude some components and expendable items such as oil, filters, etc. *Valid for three years from the date of new vehicle purchases. All Isuzu warranties are subject to mandatory prescribed terms under Australian Consumer law including customer guarantees. For more details visit the Isuzu website which explains Isuzu warranties in more detail, or alternatively contact your local dealer. All warranties commence from date of delivery.

ISUZU AUSTRALIA LIMITED ABN 97 006 962 572 ("IAL"). The information in this spec sheet was correct at time of printing, but all measurements, specifications and equipment are subject to change without notice. Some equipment may have been changed and/or is available at extra cost. IAL may make changes at any time without notice, in prices, colours, materials, equipment and models. IAL makes all reasonable attempts to ensure the availability of all vehicles and equipment. The information in this spec sheet is general in nature. Your Isuzu dealer can confirm all measurements, specifications and vehicle / equipment availability upon request. To the extent permitted by the law, IAL is not liable to any person as result of reliance on the content of this spec sheet.

December 2015, ARK0860

We
share
the
load.

ISUZU
RELIABILITY IS EVERYTHING