

ISUZU

SPECIFICATIONS

NLR 45-130 CNG

AMT



Images are for illustrative purposes only. NLR 45-150 Traypack and NPR 45/55-155 Tradepack pictured. Tray body and accessories shown are fitted to these models only.

AUSTRALIA'S TOP SELLING TRUCK BRAND SINCE 1989.

AT A GLANCE

GVM	4,500 kg
GCM	7,000 kg
Power	96 kW @ 3,200 rpm
Torque	353 Nm @ 1,400 rpm

ADVANCED TECHNOLOGY

Emissions: JNLT 05 - meets ADR 80/03	Anti-lock Braking System (ABS)
Multipoint injected CNG engine	Idle stop fuel saving system
Driver and passenger airbag with seatbelt pretensioner	Electric mirrors
ECE-R29 compliant cab	Independent front coil suspension
	Cornering lamps



We
share
the
load.

ISUZU
RELIABILITY IS EVERYTHING

DRIVELINE AND CHASSIS SPECIFICATIONS

ENGINE: CNG 130 (ISUZU 4HV1)

- Type:** 4 cylinder SOHC
- Displacement:** 4,570 cc
- Compression ratio:** 12.5:1
- Bore x Stroke:** 115 mm x 110 mm
- Max power (JIS D 1001 - NET):** 96 kW (129 HP) @ 3,200 RPM
- Max torque (JIS D 1001 - NET):** 353 Nm (260 lb.ft) @ 1,400 RPM
- Induction system:** Naturally aspirated.
- Ignition system:** Direct coil-over-spark plug ignition.
- Fuel injection:** Multipoint CNG injection.
- Emission control system:** Three-way exhaust catalyst. ADR 80/03 (J-NLT05) compliant.

CLUTCH

- Fully automated hydraulically controlled wet clutch and fluid coupling with lock up.

TRANSMISSION

Isuzu MYY-5A

- 5 speed Automated Manual Transmission (AMT) with both fully automatic and clutchless manual operation modes.
- PTO provision on LHS of transmission case. PTO drive from counter gear.
- Gear ratios (:1)

1st	2nd	3rd	4th	5th	Rev
5.315	2.908	1.558	1.000	0.721	5.068

AXLES

- Front:** Isuzu FI026
- Fully independent wishbone. 2,600 kg capacity.
- Rear:** Isuzu R050
- Full floating Banjo type. Four differential pinions. 5,000 kg capacity.
- Drive ratio: 4.777:1

SUSPENSION

- Front:
- Coil springs.
 - Double acting hydraulic shock absorbers.
- Rear:
- Taper-leaf main spring, taper-leaf helper spring.
 - Double acting hydraulic shock absorbers.

BRAKES

- Auto adjusting front disc and rear drum brakes with dual circuit hydraulic control, vacuum assistance and electronic brake force distribution (EBD).
- ABS.
- Front disc diameter: 265 mm
- Rear drum size: 290 x 75 mm
- 190 mm diameter drum park brake mounted on rear of transmission.
- Vacuum controlled exhaust brake.

STEERING

- Power assisted rack and pinion.
- Turns lock to lock: 4.2
- Maximum angle: 38° (inside wheel) / 34° (outside wheel)

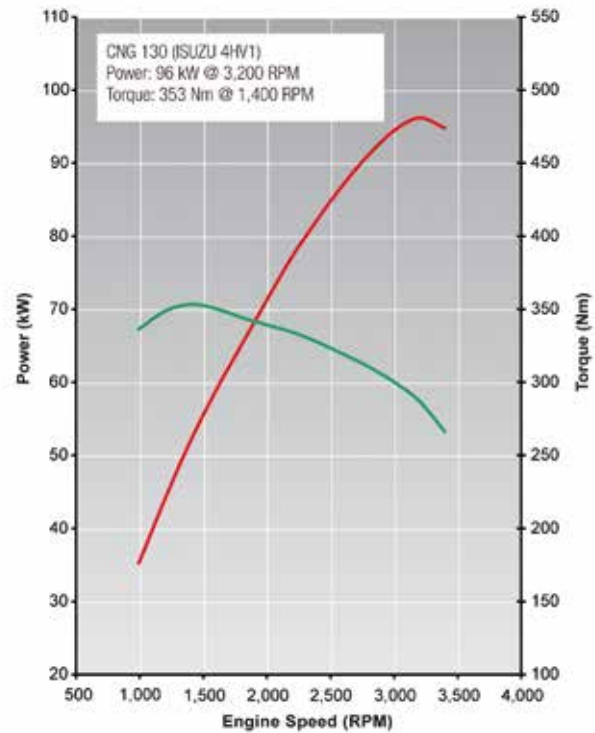

WHEELS AND TYRES

- 16 x 5.5J five stud steel wheels.
- 195/75R16C 107/105R Michelin Agilis Tubeless.
- Maximum tyre rating:
 - Steer axle: 1,950 kg
 - Drive axle: 3,700 kg
- 1 frame mounted spare wheel and tyre assembly.

CHASSIS FRAME

- Cold rivetted ladder frame. SAPH440 weldable steel sidemembers.
- Frame dimensions:
 - Side rail (mm): 180 x 65 x 4.0
 - Rear frame width (mm): 700

FUEL SYSTEM

- 2 x steel CNG tanks with 150L liquid capacity each.
- Operating pressure: 20 MPa / 3,000 psi approx.

ELECTRICAL SYSTEM

- 24 volt electrical system.
- 80 amp alternator.
- 4.5 kW starter motor.
- 2 x 80D26L (630 CCA) batteries connected in series.

CABIN SPECIFICATIONS AND APPOINTMENTS

CAB EXTERIOR

- All steel construction. High tensile steel used for cab underframe.
- Manual cab tilt to 45° with torsion bar assistance.
- Complies with ECE-R29 cab strength standard.
- Heavy duty non slip entry steps.
- 90° opening internally reinforced front doors.
- Water spray suppression guards and front mudflaps.
- Laminated windscreen with shade band.
- Two speed windscreen wipers with intermittent wipe mode.
- Halogen multi-reflector headlamps incorporating turn signals. Additional door mounted integrated side indicator/cornering lamps.
- Combination brake, turn, reverse and marker lamps, registration plate illumination lamps. Extended wiring harness. Reverse alarm.
- Heated and powered exterior main mirrors with flat glass and additional independently adjustable convex “spot” mirrors.
- Body coloured grille.
- Body coloured impact resisting polycarbonate bumper with steel backing frame.

CAB INTERIOR

- Contoured adjustable driver's bucket seat.
- Front passenger bench seat with 2 seat capacity.
- 3-point lap sash seatbelts in all outboard seating positions. Driver and outboard front passenger seatbelts fitted with pretensioner. Centre seat lap belts.
- Driver and outboard front passenger airbag.
- Driver's footrest.
- Door and roof pillar entry assist grips.
- Full interior trim, padded roof lining and vinyl floor covering. Driver and passenger windscreen header storage shelf.
- Tilt/Telescopic adjustable steering column, soft feel urethane steering wheel.
- Electric windows.
- Central locking with remote keyless entry.
- Twin cup holders. 24V cigarette lighter. Dashboard hook.
- Front door mounted storage pockets and driver's side ashtray.
- Fully integrated air conditioning and heater/demister with 4-speed fan and outlets for windscreen, side windows, face and floor.
- Fluorescent type interior lamp with On/Door/Off switch.
- 2 DIN, two speaker radio/CD/DVD Digital Audio Visual Entertainment (DAVE) unit with 6.2" LCD touch screen. DAB+ digital radio and fully integrated Bluetooth with voice recognition. 4GB internal storage for music files. USB/SD card and auxiliary input connection provisions.
- DIN sized compartment for storage or for CB radio installation.

DRIVER CONTROLS

- Key-operated engine start/stop and steering lock.
- Idle stop system on/off.
- AMT slow/fast gear engagement control, 1st gear start and normal/economy gear selection modes.
- **Left side combination stalk:** Windscreen wipers, washers and exhaust brake.
- **Right side combination stalk:** Turn signals and headlamps.

INSTRUMENTATION

- Electronically driven speedometer and tachometer. Digital odometer with integrated dual tripmeter. Engine coolant temperature and fuel level gauges.
- **Warning lamps:** Check engine, oil pressure, ABS, SRS airbag, alternator charge, service brakes, park brake, seatbelt unfastened, low fuel level, check AMT.
- **Indicator lamps:** Idle stop system, high beam, exhaust brake, turn signals, econo-mode, 1st gear start.
- Gear selection display.

OPTIONS AND GENUINE ACCESSORIES

Include the following (extra cost, request a brochure and further details from your Isuzu dealer):

Digital Audio Visual Entertainment unit:

- Isuzu satellite navigation including three years of free updates.
- Supports up to four camera inputs, one camera and rear microphone input active when reversing. Reversing sensors.
- Tyre pressure monitoring system.
- Cables for full iPod/iPhone/iPad compatibility and connection to other external audio visual devices.

Other:

- Airbag compatible bullbar.
- 2,500kg rated towbar.

ISUZU CARE

Isuzu Care gives truck owners access to products and services including Roadside Assist, Service Agreements, Extended Care, Extended Isuzu Assist and the Isuzu Care Centre. Call 1800 035 640.

WEIGHTS (kg)

Models	Ratings*		Loading Limit* (at ground)		Cab Chassis Weight #		
	GVM	GCM	Front	Rear	Front	Rear	Total
NLR 45-130 CNG	4,500	7,000	1,950	3,700	1720	820	2540

* Vehicle ratings and front/rear weight limits are subject to government regulatory requirements and weight distribution analysis. Consult your Isuzu dealer to select the correct vehicle for your specific application. # Cab chassis only as supplied with full fuel.

DIMENSIONS (mm)

Models	WB	OAL	FOH	ROH	EA	CE	RT	ORT	CH	FFA (unladen)	RFA (unladen)	RFH (unladen)	Turn Circle (m)
													KERB TO KERB
NLR 45-130 CNG	3,360	6,025	1,100	1,565	2,675	4,462	1,425	1,855	2,300	600	710	745	12.0

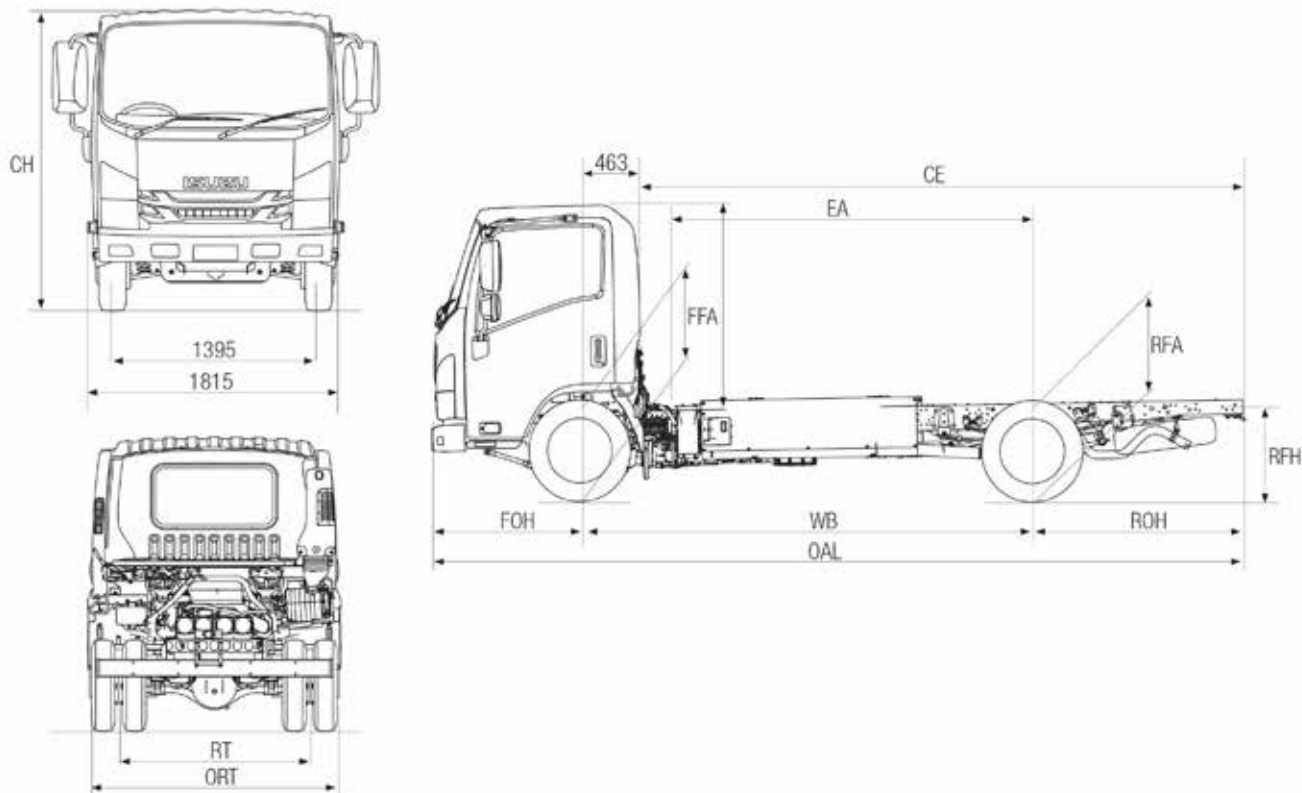

PERFORMANCE (calculated - typical paved road)

		Geared Speed* (top gear at peak power engine RPM)	Low Speed Gradeability (lowest forward gear assuming no wheel slip)	Engine Speed (top gear at 100km/h)
NLR 200 CNG	At 4,500kg GVM	118km/h @ 3,200 RPM	54%	2,715 RPM

*Maximum speed achievable depends on vehicle frontal area as well as other factors. Consult your Isuzu dealer for more detailed information.

ISUZU WARRANTIES

STANDARD¹

New Vehicle	3 years • 100,000km • 2,000 hours
Cab Perforation Corrosion	3 years • unlimited km
Isuzu Assist: 24 hour roadside assistance (3 years, unlimited km)*	

EXTENDED CARE²

Extended Warranty: 5 years • 250,000km • 4,500 hours
Isuzu Assist: 24 hour roadside assistance (5 years, unlimited km)

ORDER CODES

Model	Code
NLR 45-130 AMT CNG	NH-NLRAL-D15

¹Subject to the conditions outlined in the IAL New Vehicle Warranty, the Isuzu NLR models carry a standard factory warranty which covers the owner: (i) for the entire vehicle, for the first 36 months or 100,000 km or 2,000 hrs (whichever comes first). (ii) against cab perforation corrosion, for 36 months and unlimited kilometres. ² Extended Warranty as illustrated may be purchased to cover the owner against the failure of original components, but may exclude some components and expendable items such as oil, filters, etc. *Valid for three years from the date of new vehicle purchases. All Isuzu warranties are subject to mandatory prescribed terms under Australian Consumer law including customer guarantees. For more details visit the Isuzu website which explains Isuzu warranties in more detail, or alternatively contact your local dealer. All warranties commence from date of delivery. ISUZU AUSTRALIA LIMITED ABN 97 006 962 572 ("IAL"). The information in this spec sheet was correct at time of printing, but all measurements, specifications and equipment are subject to change without notice. Some equipment may have been changed and/or is available at extra cost. IAL may make changes at any time without notice, in prices, colours, materials, equipment and models. IAL makes all reasonable attempts to ensure the availability of all vehicles and equipment. The information in this spec sheet is general in nature. Your Isuzu dealer can confirm all measurements, specifications and vehicle / equipment availability upon request. To the extent permitted by the law, IAL is not liable to any person as result of reliance on the content of this spec sheet. December 2015, ARK0891

We
share
the
load.

ISUZU
RELIABILITY IS EVERYTHING