



**Model:** FVR 950  
**GVM:** 16,000kg  
**GCM:** 24,000kg  
**Engine type:** Isuzu SiTEC 230  
**Displacement:** 7127cc  
**Power:** 169kW @ 2500rpm  
**Torque:** 667Nm @ 1500rpm

# FVR 950

Cab/Chassis specification as at January 1999.  
RGS/IGM2706

## CABIN SPECIFICATIONS AND APPOINTMENTS

### CAB EXTERIOR

- All steel cab with welded strengthening ribs and side door impact beams. Torsion bar assisted manual tilt to 45°.
- 4 silicon filled rubber cab isolators.
- Cation electrodeposition primer.
- Bumper bar with step holes and footplate.
- Halogen headlamps, hinged for easy bulb replacement.
- Park lamps and cab clearance lamps.
- Turn signal lamps in front bumper and over wheel arches.
- 2 speed wiper/washer with variable intermittent mode.
- Triple washer jets mounted on wiper arms.
- Tinted, laminated windscreen; tinted, toughened side and rear glass.
- West Coast type rear view mirrors.
- Alloy non-slip cab entry steps.
- Lift up front access panel for clutch and windscreen washer fluids, cab air filter screen. Engine fluid check points at rear of cab.

### CAB INTERIOR

- Fully trimmed cab interior with cloth seat facings, formed roof lining. Overhead storage lockers. Driver and passenger sun visors.
- Pull out drinks holder in centre fascia, cigarette lighter with ash trays in doors.

- Isringhausen ISRI 6500/517 air suspension driver's seat with auto weight adjustment to 130kg. Height, rake and back rest recline adjustment. Pneumatic lumbar support.
- Outboard reclining passenger seat. Folding centre seat back with lockable compartment and tray.
- Outboard lap/sash seat belts with emergency locking retractors, centre lap seat belt.
- Tilt/telescopic adjustable steering column, soft feel urethane steering wheel.
- Easy entry grab handles on 'A' and 'B' pillars.
- Heater demister with 4 speed fan, 4 outlet vents to screen, 5 fascia outlets, 5 foot outlets, demister ducts to door glass.
- Eurovox AM/FM radio cassette with digital clock, dash mounted. Remote seek/volume and mute switch located on dash to right of steering wheel.
- DIN standard aperture in dash for CB radio.
- 12 Volt /100W cigarette lighter type electrical socket located in centre console.
- 24 Volt - 2 pin accessory plug in centre console.
- Park brake activation lever at left side of driver's seat.
- Rear vision mirror.
- Passenger side assist grip.
- Driver's left foot rest.
- Cab exhaust vents rear/upper cab.
- Business card clip. Coat hook at rear of cab.
- Elastic mesh pocket on driver's door.

### CONTROLS

- Left side combination stalk switch for exhaust brake, windscreen wipers and washer, hazard lamps.
- Right side combination stalk switch for headlamps, high beam and turn signals.
- Engine idle speed adjust control.
- Key operation for engine start and stop, external engine crank switch for service when cab is tilted.
- 3 way switch for interior lamp activated by driver and passenger doors.

### INSTRUMENTATION

- GAUGES: Speedometer, odometer, trip meter and tachometer. Gauges for coolant temperature, fuel level and brake air pressure.
- WARNING LAMPS: With warning bulb check switch. Battery charge, oil pressure, low air pressure, brake system, stop and tail light failure.
- INDICATOR LAMPS: Turn signals, parking brake on, high beam on, exhaust brake engaged. Reversing lamp and beeper.

### TOOLS

- Lockable tool box. 10,000kg capacity jack and wheel changing tools, tool kit.

## ISUZU NEW TRUCK WARRANTIES

| 12 MONTHS | 24 MONTHS                       | 36 MONTHS                                 |
|-----------|---------------------------------|---|
|           | 24 MONTH NEW VEHICLE WARRANTY   | TRUCKPOWER EXTENDED NEW VEHICLE WARRANTY* |
|           | 36 MONTH POWERTRAIN WARRANTY    |   |
|           | 36 MONTH CAB CORROSION WARRANTY |   |

\*36 months or by 150,000kms whichever occurs first.

| 12 MONTHS | 24 MONTHS                       | 36 MONTHS                                 | 48 MONTHS |
|-----------|---------------------------------|---|-----------|
|           | 24 MONTH NEW VEHICLE WARRANTY   | TRUCKPOWER EXTENDED NEW VEHICLE WARRANTY* |           |
|           | 36 MONTH POWERTRAIN WARRANTY    |   |           |
|           | 36 MONTH CAB CORROSION WARRANTY |   |           |

\*48 months or by 200,000kms whichever occurs first.

| 12 MONTHS | 24 MONTHS                       | 36 MONTHS                                 | 48 MONTHS | 60 MONTHS |
|-----------|---------------------------------|---|-----------|-----------|
|           | 24 MONTH NEW VEHICLE WARRANTY   | TRUCKPOWER EXTENDED NEW VEHICLE WARRANTY* |           |           |
|           | 36 MONTH POWERTRAIN WARRANTY    |   |           |           |
|           | 36 MONTH CAB CORROSION WARRANTY |   |           |           |

\*60 months or by 250,000kms whichever occurs first.

Subject to the conditions outlined in the I-GM New Vehicle Warranty, the Isuzu FVR models carry a standard factory warranty which covers the owner: (i) for the entire vehicle, for the first 24 months or 100,000km (whichever comes first) (ii) for the powertrain, which runs concurrently for 36 months or 150,000km (whichever comes first) (iii) against cab corrosion, for 36 months and unlimited kilometres.

A TruckPower Extended Warranty as illustrated is available by purchase to cover the owner against the failure of original components, but excludes some components and expendable items such as oil, filters, etc. Please consult with your Isuzu Dealer for full details obtainable from a dedicated brochure available to customers.

**ISUZU**  
RELIABILITY IS EVERYTHING

ISUZU-GENERAL MOTORS AUSTRALIA LTD A.C.N. 006 962 572. PLEASE NOTE: as the policy of I-GM is one of continual product improvement, all specifications and equipment are subject to change without notice. No I-GM dealer or other person is authorised or permitted to give or make any statement, assertion or undertaking in relation to the quality, performance, characteristics, descriptions or fitness for any purpose of any I-GM product or in connection with the supply of any I-GM product which is at variance with any written statement, assertion or undertaking on any of these subjects given or made by I-GM in its published sales literature, and the company accepts no liability for any such unauthorised action. I-GM has franchised dealers in many parts of Australia, for the sale of service, parts and the provision of service to the owners of I-GM products. Every endeavour is made to ensure that such dealers carry adequate stocks of service parts and are equipped to provide satisfactory service, but makes no promise, other than that contained in the I-GM new vehicle warranty, that such parts or service facilities will be available or available at any specific location or at any particular time. A word about this specification sheet. We have tried to make it as comprehensive and factual as possible. However, since the time of printing some of the information you will find here may have been updated. Also, some of the equipment shown or described through this specification sheet may have been changed and/or is available at extra cost. And the right is reserved to make changes at any time without notice, in prices, colours, materials, equipment and models. Your I-GM dealer has details and before ordering, you should ask him/her to bring you up to date.

## DRIVELINE SPECIFICATIONS

### ENGINE: ISUZU SITEC 230

Isuzu 6HE1-TC Turbo charged and intercooled 6 cylinder, overhead camshaft, four stroke, direct injection, diesel.

**BORE X STROKE:** 110 mm x 125 mm.

**DISPLACEMENT:** 7127 cc.

**COMPRESSION RATIO:** 16.9 : 1.

**POWER:** 169 kW @ 2500 RPM. (ISO 1585)

**TORQUE:** 667 Nm @ 1500RPM. (ISO 1585)

### COOLING SYSTEM

• 7 blade plastic cooling fan 560 mm diameter with thermatic fan clutch.

• Corrugated fin radiator with fan shroud and triple row core.

Dimensions: 800 mm x 636 mm x 54 mm.  
Frontal area 5,088 cm<sup>2</sup>.

• Coolant capacity 29.0 litres.

### AIR INTAKE SYSTEM

• Donaldson 13" diameter, dry element, two stage filter. Vertical intake stack with rain head.

• Turbocharger and Air-To-Air Intercooler.

Intercooler dimensions:

540 mm x 470 mm x 53 mm. Total intercooler frontal area 2,540 cm<sup>2</sup>.

### EXHAUST SYSTEM

• Horizontal exhaust muffler with vertical exhaust pipe.

• Air controlled, butterfly type exhaust brake.

### FUEL SYSTEM

• In line plunger, Bosch 'MD' type fuel injection pump with 'TICS' electrical timing and injection control and mechanical 'RLD' type all speed governor.

• In line filter, see through water separator with drain cock.

• Single fuel tank, capacity 180 litres.

### TRANSMISSION

#### ISUZU MLD7Q 7 speed overdrive

• Constant mesh with synchromesh on gears 2-7. Oil capacity 8.3 litres.

• Pneumatic gearshift assistance

• Gear ratios to 1:

|       |       |       |       |       |       |       |       |
|-------|-------|-------|-------|-------|-------|-------|-------|
| 1st   | 2nd   | 3rd   | 4th   | 5th   | 6th   | 7th   | Rev   |
| 7.166 | 4.526 | 2.919 | 1.954 | 1.254 | 1.000 | 0.756 | 7.276 |

• Maximum geared speed 120 km/h.

• Electronically road speed limited to 100km/h

### CLUTCH

• Hydraulic control dry single plate. 380 mm (15") diameter.

• Asbestos free lining material. Total lining area (both sides) 1364 cm<sup>2</sup>.

### FRONT AXLE

ISUZU F063 CAPACITY 6300KG

• Reverse Elliot I-beam type. King Pin diameter 50 mm with cylindrical roller thrust bearing.

### REAR AXLE

MERITOR RS-23-160G CAPACITY 10,500KG

• Banjo type, fully floating, single reduction.

• Hypoid type ring gear, 457 mm diameter. Oil capacity 15.0 litres.

• Rear Axle Ratio: (: 1)

|  |        |       |            |
|--|--------|-------|------------|
|  | Medium | Long  | Lo Profile |
|  |        | 5.625 | 5.375      |

## CHASSIS SPECIFICATIONS

### CHASSIS FRAME

• Parallel rail, ladder type channel section, cold rivetted.

• Straight frame for easy body mounting. Frame width 850 mm.

• Side member dimensions:

FVR 950 Medium:

254mm x 85mm x 8mm.

FVR 950 Long & Lo Profile:

258mm x 85mm x 10mm.

• Frame reinforcement angle section:

FVR 950 Medium:

224mm x 77mm x 4.5mm.

FVR 950 Long & Lo Profile:

224mm x 77mm x 4.5mm (cab back).

224mm x 77mm x 6mm (rear axle).

• Material SAPH440 weldable mild steel.

### SUSPENSION

Semi-elliptical, alloy steel tapered multi-leaf springs. Fully wrapped eye with greasable shackles.

#### FRONT

• 1470mm x 80mm x 12mm x 2 leaves.

1470mm x 80mm x 13mm x 6 leaves.

• Hydraulic, double acting, telescopic shock absorbers.

• Stabiliser bar.

#### REAR

• Main: 1420 x 100mm x 12mm x 8 leaves

Aux: 980 x 100mm x 10mm x 2 leaves

980 x 100mm x 11mm x 4 leaves

• Stabiliser bar.

### BRAKES

• Meritor 'Q Plus' full air 'S' cam dual circuit, front and rear leading and trailing shoes. Drum diameter front and rear 419 mm. Total swept area 8688cm<sup>2</sup>.

• Asbestos free lining material.

• Air dryer.

• Air tank capacity 67.5 litres.

• Nylon brake air tubing.

• Spring park brake acting on rear wheels.

### STEERING

• Fully integral power assisted recirculating ball type.

• Gear ratio 22.4 : 1. Turns lock to lock 4.5.

• Gear driven vane type oil pump. Oil capacity 2.5 litres.

### WHEELS AND TYRES

#### WHEELS

• 8.25 x 22.5, 10 stud disc wheels.

• Number of wheels and tyres 7, including spare. Winch type spare wheel carrier.

#### TYRES

• FVR 950 Medium & Long: 11R22.5 148/145L tubeless radial tyres front and rear.

Type: Michelin XZE1 (Front and Spare)

Michelin XDE1 (Rear)

• FVR 950 Lo Profile: 275/70R22.5 148/145L tubeless radial tyres front and rear.

Type: Michelin XZE2 (Front and Spare)

Michelin XDA (Rear)

• Load and speed ratings per tyre:

3150kg (single) / 2900kg (dual)

120 km/h: FVR Medium & Long.

130 km/h: FVR Lo Profile.

### ELECTRICAL SYSTEM

• Batteries - 2 x 12 volt / 65 amp/h, negative earth.

• Alternator - 24 volt / 40 amp.

• Starter motor - 24 volt / 4.5 kW.

• Rear stop and tail lamps and licence plate lamp with long leads for variable body mounting.

## MODEL RATINGS AND DIMENSIONS

| MODELS             | RATINGS  |          | TARE MASS* |         |         | DIMENSIONS (mm) |        |       |       |       |             |           |             | TURNING CIRCLE | NOMINAL MAX BODY LENGTH* |           |
|--------------------|----------|----------|------------|---------|---------|-----------------|--------|-------|-------|-------|-------------|-----------|-------------|----------------|--------------------------|-----------|
|                    | GVM      | GCM      | TOTAL      | FRONT   | REAR    | WB              | OAL    | ROH   | CA    | CE    | FFH UNLADEN | FFH LADEN | RFH UNLADEN |                |                          | RFH LADEN |
| FVR 950 MEDIUM     | 16,000kg | 24,000kg | 4,775kg    | 2,805kg | 1,970kg | 4,250           | 6,050  | 1,900 | 3,540 | 5,440 | 965         | 941       | 1,050       | 951            | 16.8m                    | 5,645     |
| FVR 950 LONG       | 16,000kg | 24,000kg | 5,165kg    | 2,995kg | 2,170kg | 6,050           | 10,020 | 2,700 | 5,340 | 8,040 | 960         | 941       | 1,050       | 951            | 22.5m                    | 8,395     |
| FVR 950 LO PROFILE | 16,000kg | 24,000kg | 5,150kg    | 2,990kg | 2,160kg | 6,050           | 10,020 | 2,700 | 5,340 | 8,040 | 915         | 898       | 1,005       | 908            | 22.5m                    | 8,395     |

\* Estimated mass of cab/chassis with oil, water and fuel tank containing 10 litres of fuel and excluding spare wheel and tools.

\* Subject to weight distribution

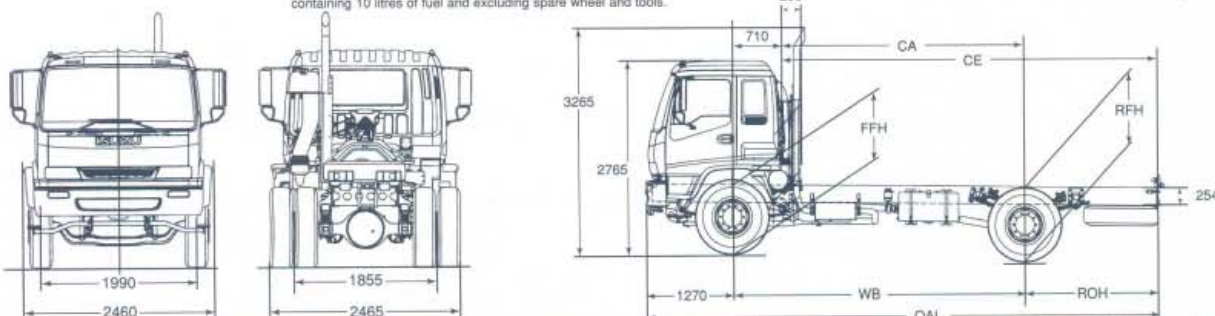

For further information regarding Cab/Chassis dimensions your Isuzu Dealer can access detailed Body Builders diagrams from the Isuzu Truck Data Manual.