



ISUZU SCR 480B CUSTOM (S MODEL)

GMH MODEL: FSR 11LTX
ORDERING CODE: 8DR 02

STANDARD GVM 10500 kg
STANDARD GCM 15000 kg
TARE MASS (est) 3260 kg

DRIVELINE SPECIFICATION

ENGINE

Model: ISUZU 6BD1-T
Type: 6 cylinder Turbo-charged Diesel
Displacement: 5785cc
Max power: 127kW @ 3000 rpm
Max torque: 470 Nm @ 2000 rpm
Bore & Stroke 102x118mm
Compression ratio: 170:1
RAC Rating: 38.7

TRANSMISSION

Model: ISUZU MBG 5C
Type: 5-speed direct drive
Gear ratios (to 1)
1st 6.890
2nd 3.918
3rd 2.419
4th 1.569
5th 1.000
Rev 6.304

AXLE, FRONT

Type: Reverse Elliot I beam
Capacity: 3400 kg

AXLE, REAR

Type: Banjo fully floating
Capacity: 7700 kg
Ratio: 5.429:1
Final Gear: 343mm diameter. Hypoid

BRAKES

Air over hydraulic

WHEELBASE

4800mm

CHASSIS RATINGS

GROSS COMBINATION and GROSS VEHICLE MASS RATING (KG):			Estimated kerb mass (chassis and cab with oil, water and full fuel tank), (kg)		
GVM 10500	GCM 15000	Tyres 8.25R x 20 14 ply (Radials)	3405	1365	Total 3405

DIMENSIONS

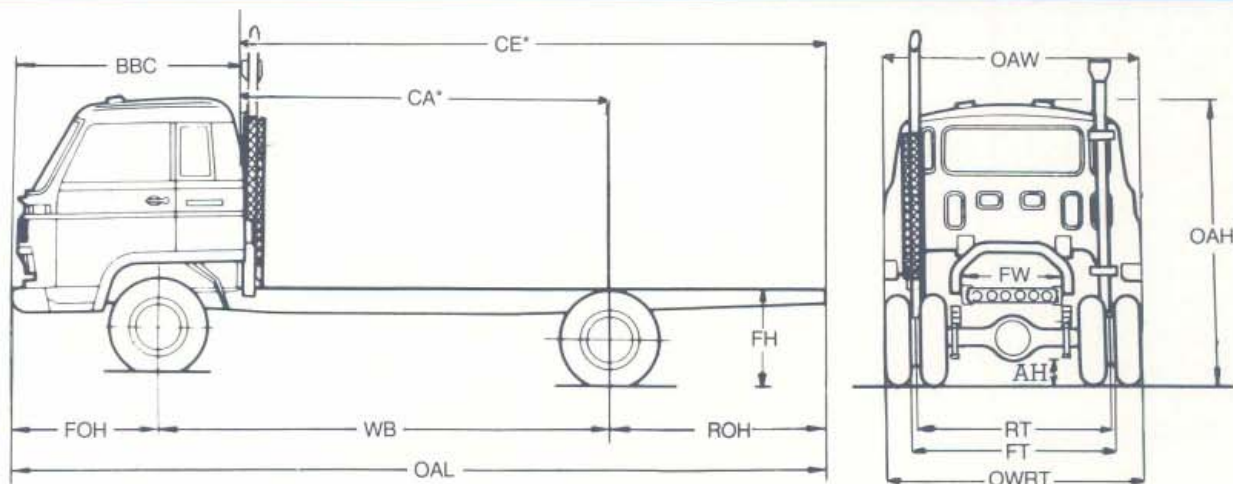

LENGTHS

		(mm)
Overall length	OAL	8110
Wheelbase	WB	4800
Cab to axle	CA*	4100
Cab to end of frame	CE*	6200
Front Overhang	FOH	1210
Rear Overhang	ROH	2100
Bumper to back of cab	BBC	1910

* CA & CE dimensions are effectively reduced by 300mm with the fitment of vertical exhaust pipe and protector.

WIDTHS

		(mm)
Overall width	OAW	2170
Frame width	FW	800
Front track	FT	1710

Rear track	RT	1630
Outside width rear tyres	OWRT	2165

HEIGHTS

Overall height	OAH	2420
Ground to top of frame (at rear)	FH	940
Rear axle clearance	AH	270

TURNING CIRCLE

Kerb to kerb	(m)	18.2
Wall to wall		19.2



ISUZU
Reliability is everything.

ISUZU SCR 480B CUSTOM(S MODEL)

CAB/CHASSIS COMPONENT SPECIFICATIONS

AXLE, FRONT

Type: Reverse Elliot I beam
Capacity: 3400 kg

AXLE, REAR

Type: Banjo fully floating
Capacity: 7700 kg
Ratio: 5.429:1
Final Gear: 343mm diameter. Hypoid

BRAKES, SERVICE

Type: Air over hydraulic dual circuit, front two leading, rear dual two leading. Exhaust brake.
Total lining area: 3410cm²
Brake drum diameter: 370mm

BRAKE, PARKING

Type: Mechanical expanding at rear of transmission.

CABIN EXTERIOR

All steel cab, manual tilt. Laminated windshield. 2 speed windshield wiper/washer with intermittent setting. West-coast type rear view mirrors. Dual round sealed beam headlamps. Fog lamps. Vertical air intake stack. General hand tools and 7000kg capacity jack. Spare wheel and tyre.

INTERIOR

Custom cab interior. Adjustable driver's suspension seat with adjustable lumbar support. Tilt telescopic adjustable steering wheel. Adjustable roof vents. Rear side vent windows. Passenger bucket seat and second passenger centre seat which lifts up for coolant and oil check. AM Radio. Heater/demister with 4 speed fan. Driver and passenger sunvisors. Suspended roof lining.

INSTRUMENTATION

Speedometer and odometer. Tachometer. GAUGES for engine temperature, brake air pressure and fuel level. INDICATOR LAMPS for turn indicators, headlamp high beam, exhaust brake on and park brake on. WARNING LAMPS for low brake fluid, low brake air pressure, battery charge, clogged air filter, oil pressure. Left side combination switch for exhaust brake & two speed wipers with intermittent setting. Hazard warning switch. Fog lamp switch. Right combination switch for headlamps, turn signal and headlamp dip. Key operation auto engine stop.

CLUTCH

Type: Hydraulic control. Dry single plate with cushioning springs.
Size: 325mm diameter.

ENGINE SPECIFICATION

Type: 6 cylinder Turbo-charged diesel
Displacement: 5785cc
Max. Power: 127 kW @ 3000 rpm
Max torque: 470 Nm @ 2000 rpm
Bore and Stroke: 102 x 118 mm
Compression ratio: 17.0:1
RAC rating: 38.7

YOUR GMH ISUZU DEALER:

LUBRICATION

Pressure feed with full flow paper element filter & partial oil filter oil cooler. Capacity: 175 litres including filters.

COOLING

Heavy duty radiator. Size: 622 x 559 x 53 mm
Frontal area: 0.348m²

AIR CLEANER

Paper element, Donaldson 11" cartridge type. Long vertical air intake stack.

FUEL SYSTEM

Fuel injection pump: In line plunger Bosch A with mechanical governor

Pre-fuel filter:

Fuel tank capacity: 200 litre.

ELECTRICAL SYSTEMS

Batteries: 2 x 12V-53A/H

Alternator: 24V-25A

Starter: 24V-4.5kW

FRAME

Type: Ladder type channel section
Side member dimensions: 225 x 70 x 6mm.
Frame reinforcement at: Cab back-203 x 64 x 4.5 mm
Angle Section. Rear axle-213 x 64 x 3.2 mm Channel Section

STEERING

Type: Power assisted recirculating ball.

Gear ratio: 22.4:1

SUSPENSION, FRONT

Type: Semi-elliptical alloy steel leaf springs
Size: (Length x width x thickness mm—no. of leaves)
1200 x 70 x 10—8

Shock absorbers: Hydraulic double acting telescopic

SUSPENSION, REAR

Type: Semi-elliptical alloy steel leaf springs
Size: (Length x width x thickness mm—no. of leaves)
main 1300 x 70 x 11-8

Auxiliary: 850 x 70 x 11-8

TRANSMISSION

Type: Isuzu 5 speed direct drive

Gear ratios (to 1)

1st 6.890 2nd 3.918 3rd 2.419 4th 1.569

5th 1.000 Rev 6.304

TYRES AND WHEELS

Tyre size: 8.25R x 20 — 14 ply Radials.

Wheel type and size 6.50T x 20, 8 stud disc wheels.

GMH 12/20 WARRANTY

Every Isuzu is covered by the GMH warranty which covers the vehicle for the first 12 months or 20,000 kilometres.

Major engine components and driveline components have additional extended warranty. Please consult your GMH/ISUZU dealer for complete and accurate details.

PLEASE NOTE: As the policy of General Motors-Holden's is one of continual product improvement, all specifications and equipment are subject to change without notice. Bodies illustrated are not standard.

No GMH Dealer or other person is authorised or permitted to give or make any statement assertion or undertaking in relation to the quality performance characteristics descriptions or fitness for any purpose of any GMH product or in connection with the supply of any GMH product, which is at variance with any written statement assertion or undertaking on any of these subjects given or made by General Motors-Holden's Limited or General Motors-Holden's Sales Pty. Ltd. in its published sales literature, and neither company accepts any liability for any such unauthorised action.

General Motors-Holden's Limited and General Motors-Holden's Sales Pty. Ltd. have franchised dealers in many parts of Australia for the sale of service parts and the provision of service to owners of GMH's products. Every endeavour is made to ensure that such dealers carry adequate stocks of service parts, and are equipped to provide satisfactory service, but neither General Motors-Holden's Ltd. nor General Motors-Holden's Sales Pty. Ltd. makes any promise, other than that contained in the New Vehicle Warranty given by General Motors-Holden's Sales Pty. Ltd., that such parts or service facilities will be available, or available at any specific location or any particular time.

General Motors Holden's Sales Pty. Ltd.



Reliability is everything.