

ISUZU

SPECIFICATIONS

NLR 200



AUSTRALIA'S TOP SELLING TRUCK BRAND SINCE 1989.

AT A GLANCE

GVM	4,500 kg
GCM	7,000 kg
Power	110 kW @ 2,800 rpm
Torque	375 Nm @ 1,600 - 2,800 rpm

UPGRADE OPTIONS

AMT Pack:

Automated Manual Transmission (AMT)

ADVANCED TECHNOLOGY

Emissions: Euro V / ADR 80/03

Meets EEV emissions standard

Driver and passenger airbag with seatbelt pretensioner

ECE-R29 compliant cab

Anti-lock Braking System (ABS)

Anti Skid Regulator (ASR)

Hill Start Aid (HSA) - except AMT pack

Electric mirrors

Independent front coil suspension

Cornering lamps



We
share
the
load.

ISUZU
RELIABILITY IS EVERYTHING

DRIVELINE AND CHASSIS SPECIFICATIONS

ENGINE: SITEC SERIES III 150 (ISUZU 4JJ1-TCS)

- Type:** 4 cylinder 16 valve with chain driven DOHC
- Displacement:** 2,999 cc
- Compression ratio:** 17.5:1
- Bore x Stroke:** 95.4 mm x 104.9 mm
- Max power (Din-net):** 110 kW (148 HP) @ 2,800 RPM
(JIS Gross): 114 kW (153 HP) @ 2,800 RPM
- Max torque (Din-net):** 375 Nm (277 lb.ft) @ 1,600 - 2,800 RPM
(JIS Gross): 388 Nm (286 lb.ft) @ 1,600 - 2,800 RPM
- Induction system:** Electronically controlled variable nozzle turbocharger with air-to-air intercooler.
- Fuel injection:** Direct injection high pressure common rail system.
- Emission control system:** Cooled EGR with exhaust Diesel Particulate Diffuser (DPD). ADR 80/03 (Euro V) compliant. EEV compliant.

CLUTCH

Standard model:

- Auto adjusting hydraulic control with vacuum assistance. Single plate 300 mm diameter.
- Total lining area: 847 cm²

AMT Pack:

- Fully automated hydraulically controlled wet clutch and fluid coupling with lock up.

TRANSMISSION

Standard model:

ISUZU MYY-5T

- 5 speed manual. Synchronesh on gears 1-5.
 - PTO provision on LHS of transmission case. PTO drive from counter gear.
 - **Gear ratios (:1)**
- | 1st | 2nd | 3rd | 4th | 5th | Rev |
|-------|-------|-------|-------|-------|-------|
| 5.315 | 3.053 | 1.655 | 1.000 | 0.721 | 5.068 |

AMT Pack:

ISUZU MYY-6S

- 6 speed Automated Manual Transmission (AMT) with both fully automatic and clutchless manual operation modes.
 - PTO provision on LHS of transmission case. PTO drive from counter gear.
 - **Gear ratios (:1)**
- | 1st | 2nd | 3rd | 4th | 5th | 6th | Rev |
|-------|-------|-------|-------|-------|-------|-------|
| 5.979 | 3.434 | 1.862 | 1.297 | 1.000 | 0.750 | 5.701 |

AXLES

Front: Isuzu FI026

- Fully independent wishbone. 2,600 kg capacity.

Rear: Isuzu R045

- Full floating Banjo type. Four differential pinions. 4,500 kg capacity.
- Drive ratio: 4.556:1 (standard model), 4.100:1 (AMT pack)

SUSPENSION

Front:

- Coil springs.
- Double acting hydraulic shock absorbers.

Rear:

- Taper leaf main, taper leaf helper spring.
- Double acting hydraulic shock absorbers.

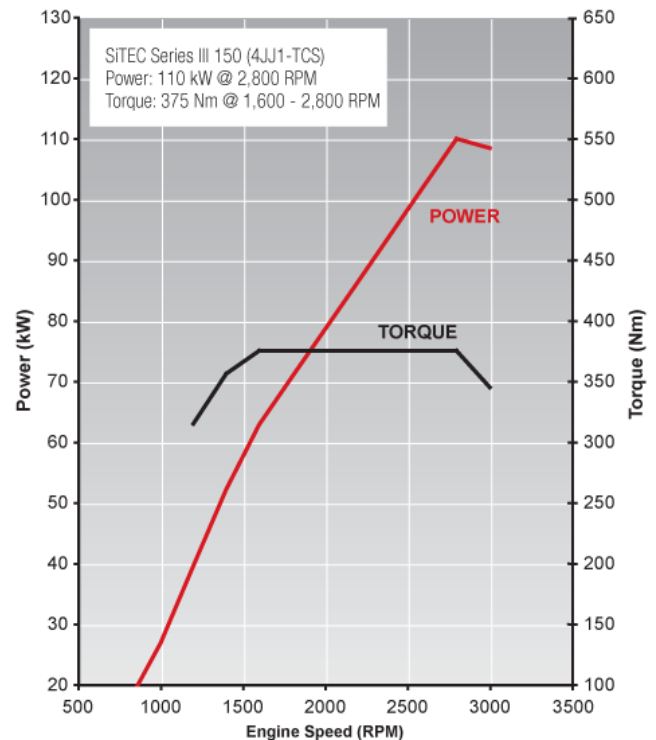

BRAKES

- Auto adjusting front and rear disc brakes with dual circuit hydraulic control, vacuum assistance and electronic brake force distribution (EBD).
- ABS and ASR traction control.
- Hill Start Aid (HSA) - except AMT pack.
- Front disc diameter: 293 mm
- Rear disc diameter: 275 mm
- 190 mm diameter drum park brake mounted on rear of transmission.
- Vacuum controlled exhaust brake.

STEERING

- Power assisted rack and pinion.
- Turns lock to lock: 4.2
- Maximum angle: 38° (inside wheel) / 34° (outside wheel)

WHEELS AND TYRES

- 16 x 5.5J five stud steel wheels.
- 195/75R16C 107/105R Michelin Agilis Tubeless.
- Maximum tyre rating
 - Steer axle: 1,950 kg
 - Drive axle: 3,700 kg
- 1 frame mounted spare wheel and tyre assembly.

CHASSIS FRAME

- Cold rivetted ladder frame. SAPH440 weldable steel sidemembers.
- **Frame dimensions:**
Side rail (mm): 180 x 65 x 4.0
Rear frame width (mm): 700

FUEL TANK

- Frame mounted steel fuel tank. 75L (short w/base), 100L (medium w/base).
- Lockable fuel cap.

CABIN SPECIFICATIONS AND APPOINTMENTS

CAB EXTERIOR

- All steel construction. High tensile steel used for cab underframe. Manual cab tilt to 45° with torsion bar assistance.
- Complies with ECE-R29 cab strength standard.
- Heavy duty non slip entry steps.
- 90° opening internally reinforced front doors.
- Water spray suppression guards and front mudflaps.
- Laminated windscreen with shade band.
- Two speed windscreen wipers with intermittent wipe mode.
- Halogen multi-reflector headlamps incorporating turn signals. Additional door mounted integrated side indicator/cornering lamps.
- Combination brake, turn, reverse and marker lamps, registration plate illumination lamps. Extended wiring harness. Reverse alarm.
- Heated and powered exterior main mirrors with flat glass and additional independently adjustable convex “spot” mirrors.
- Body coloured grille.
- Body coloured impact resisting polycarbonate bumper with steel backing frame.

CAB INTERIOR

- Contoured adjustable driver's bucket seat.
- Front passenger bench seat with 2 seat capacity.
- 3-point lap sash seatbelts in all outboard seating positions. Driver and outboard front passenger seatbelts fitted with pretensioner. Centre seat lap belts.
- Driver and outboard front passenger airbag.
- **AMT Pack:** Driver's footrest.
- Door and roof pillar entry assist grips.
- Full interior trim, padded roof lining and vinyl floor covering. Driver and passenger windscreen header storage shelf.
- Tilt/Telescopic adjustable steering column, soft feel urethane steering wheel.
- Electric windows.
- Central locking with remote keyless entry and immobiliser.
- Twin cup holders. 24V cigarette lighter. Dashboard hook.
- Front door mounted storage pockets and driver's side ashtray.
- Fully integrated air conditioning and heater/demister with 4-speed fan and outlets for windscreen, side windows, face and floor.
- Fluorescent type interior lamp with On/Door/Off switch.
- 2 DIN, two speaker radio/CD/DVD Digital Audio Visual Entertainment (DAVE) unit with 6.2" LCD touch screen. DAB+ digital radio and fully integrated Bluetooth with voice recognition. 4GB internal storage for music files. USB/SD card and auxiliary input connection provisions.
- DIN sized compartment for storage or for CB radio installation.

ELECTRICAL SYSTEM

- 24 volt electrical system.
- 80 amp alternator.
- 4.0 kW starter motor.
- 2 x 80D26L (630 CCA) batteries connected in series.

DRIVER CONTROLS

- Key-operated engine start/stop and steering lock. Engine idle speed control.
- HSA slow/fast engagement control and on/off switch (except AMT pack).
- ASR on/off.
- DPD regeneration.
- **AMT Pack:** AMT slow/fast gear engagement control, 1st gear start and normal/economy gear selection modes.
- **Left side combination stalk:** Windscreen wipers, washers and exhaust brake.
- **Right side combination stalk:** Turn signals and headlamps.

INSTRUMENTATION

- Electronically driven speedometer and tachometer. Digital odometer with integrated dual tripmeter. Engine coolant temperature and fuel level gauges.
- **Warning lamps:** Check engine, oil pressure, ABS, SRS airbag, alternator charge, service brakes, park brake, seatbelt unfastened, low fuel level.
AMT Pack: Check AMT.
- **Indicator lamps:** HSA (except AMT pack), warm up system, high beam, ASR, DPD status, exhaust brake, turn signals. AMT Pack: Econo-mode, 1st gear start.
- **AMT Pack:** Gear selection display.

OPTIONS AND GENUINE ACCESSORIES

Include the following (extra cost, request a brochure and further details from your Isuzu dealer):

Digital Audio Visual Entertainment unit:

- Isuzu satellite navigation including three years of free updates.
- Up to four reversing cameras - one with audio for reversing. Reversing sensors.
- Tyre pressure monitoring system.
- Cables for full iPod/iPhone/iPad compatibility and connection to other external audio visual devices.

Other:

- Airbag compatible bullbar.
- 2,500kg rated towbar.

ISUZU CARE

Isuzu Care gives truck owners access to products and services including Roadside Assist, Service Agreements, Extended Care, Extended Isuzu Assist and the Isuzu Care Centre. Call 1800 035 640.

WEIGHTS (kg)

Models	Ratings*		Loading Limit* (at ground)		Cab Chassis Mass #		
	GVM	GCM	Front	Rear	Front	Rear	Total
NLR 200 Short	4,500	7,000	1,950	3,700	1,415	580	1,995
NLR 200 Short AMT	4,500	7,000	1,950	3,700	1,435	600	2,035
NLR 200 Medium	4,500	7,000	1,950	3,700	1,440	620	2,060
NLR 200 Medium AMT	4,500	7,000	1,950	3,700	1,460	620	2,080

Maximum Gross Trailer Mass: 750 kg (unbraked), 2,500 kg (braked) * Vehicle ratings and axle weight limits are subject to government regulatory requirements and weight distribution analysis. Consult your Isuzu dealer to select the correct vehicle for your specific application. # Cab chassis only as supplied and including 10 litres of fuel.

DIMENSIONS (mm)

Turn Circle (m)

Models	WB	OAL	FOH	ROH	EA	CE	RT	ORT	CH	FFA (unladen)	RFA (unladen)	RFH (unladen)	KERB TO KERB
NLR 200 Short	2,490	4,735	1,100	1,145	1,805	3,172	1,425	1,855	2,155	600	695	730	8.9
NLR 200 Medium	3,360	6,025	1,100	1,565	2,675	4,462	1,425	1,855	2,180	610	720	760	12.0

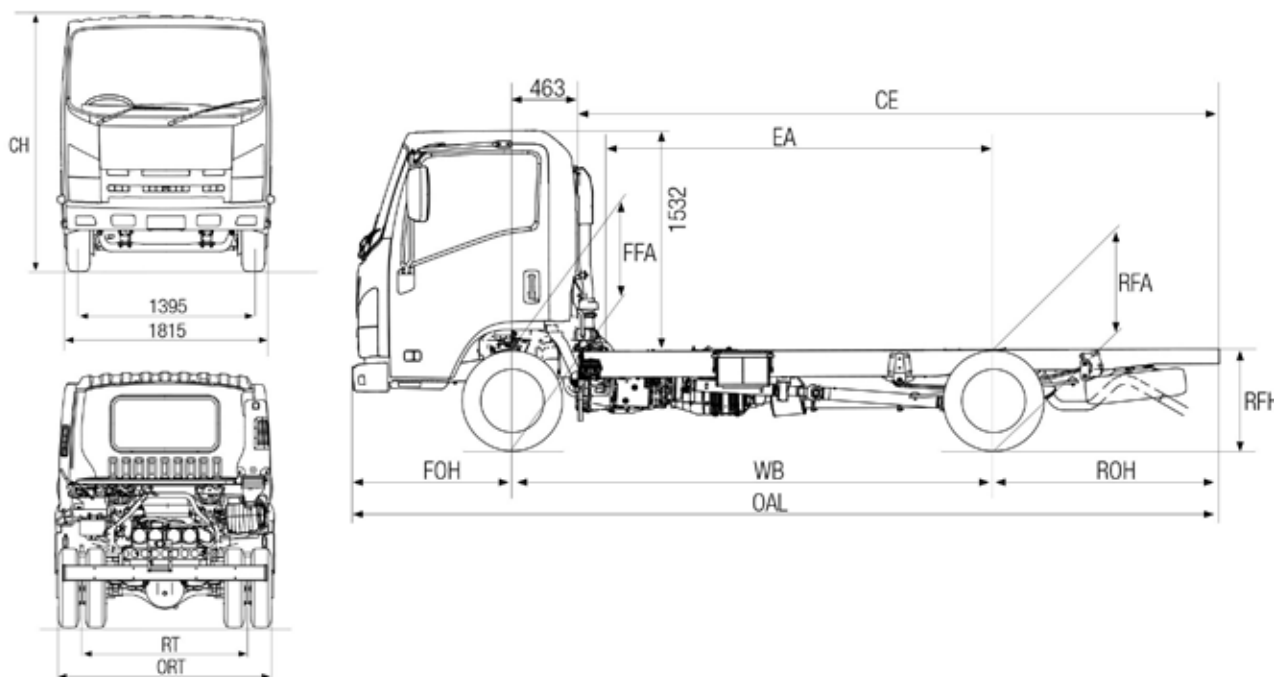

PERFORMANCE (calculated - typical paved road)

		Geared Speed* (top gear at peak power engine RPM)	Low Speed Gradeability (lowest forward gear assuming no wheel slip)	Engine Speed (top gear at 100km/h)
NLR 200	At 4,500 kg GVM	108 km/h @ 2,800 RPM	55%	2,590 RPM
NLR 200 AMT Pack	At 4,500 kg GVM	116 km/h @ 2,800 RPM	56%	2,425 RPM

*Maximum speed achievable depends on vehicle frontal area as well as other factors. Consult your Isuzu dealer for more detailed information.

ISUZU WARRANTIES

STANDARD ¹	
New Vehicle	3 years • 100,000km • 2,000 hours
Cab Perforation Corrosion	3 years • unlimited km's
Isuzu Assist: 24 hour roadside assistance (3 years, unlimited km's)*	
EXTENDED CARE ²	
Extended Warranty: 5 years • 250,000km • 4,500 hours	
Isuzu Assist: 24 hour roadside assistance (5 years, unlimited km's)	

ORDER CODES

Model	Code	Model	Code
NLR 200 Short	NH-NLRAA-A13 (MU14)	NLR 200 Medium	NH-NLRAA-B13
NLR 200 Short AMT	NH-NLRAA-Z13 (MU14)	NLR 200 Medium AMT	NH-NLRAA-D13

¹ Subject to the conditions outlined in the IAL New Vehicle Warranty, the Isuzu NLR models carry a standard factory warranty which covers the owner: (i) for the entire vehicle, for the first 36 months or 100,000 km or 2,000 hrs (whichever comes first). (ii) against cab perforation corrosion, for 36 months and unlimited kilometres. ² Extended Warranty as illustrated may be purchased to cover the owner against the failure of original components, but may exclude some components and expendable items such as oil, filters, etc. *Valid for three years from the date of new vehicle purchases. All Isuzu warranties are subject to mandatory prescribed terms under Australian Consumer law including customer guarantees. For more details visit the Isuzu website which explains Isuzu warranties in more detail, or alternatively contact your local dealer. All warranties commence from date of delivery.

ISUZU AUSTRALIA LIMITED ABN 97 006 962 572 ("IAL"). The information in this spec sheet was correct at time of printing, but all measurements, specifications and equipment are subject to change without notice. Some equipment may have been changed and/or is available at extra cost. IAL may make changes at any time without notice, in prices, colours, materials, equipment and models. IAL makes all reasonable attempts to ensure the availability of all vehicles and equipment. The information in this spec sheet is general in nature. Your Isuzu dealer can confirm all measurements, specifications and vehicle / equipment availability upon request. To the extent permitted by the law, IAL is not liable to any person as result of reliance on the content of this spec sheet. July 2014. ARK0778

We
share
the
load.

ISUZU
RELIABILITY IS EVERYTHING