

# ISUZU

SPECIFICATIONS

**NEW**  
NEW GENERATION ISUZU  
**GEN**

## FXZ 1500



AUSTRALIA'S TOP SELLING TRUCK BRAND SINCE 1989. Truck tracker 2007.

### AT A GLANCE

<b>GVM</b>	24,000 kg
<b>GCM</b>	42,500 kg
<b>Power</b>	243 kW @ 2,000 rpm
<b>Torque</b>	1,422 Nm @ 1,200 - 1,500 rpm

### ADVANCED TECHNOLOGY

- Driver airbag with seatbelt pretensioner
- ADR 42 compliant sleeper with mattress
- Anti-lock Braking System (ABS)
- Cross locks
- Electro-hydraulic cab tilt
- Coil spring cab suspension
- Front stabiliser bar
- Cruise control
- ISRI 6860 seat with integrated seatbelt

RELIABILITY IS EVERYTHING **ISUZU**

## Driveline & Chassis Specifications

### ENGINE: SITEC SERIES II 325 (ISUZU 6UZ1-TCN)

**Type:** 6 cylinder 24 valve SOHC  
**Displacement:** 9,839 cc  
**Compression Ratio:** 17.5:1  
**Bore x Stroke:** 120 x 145 mm  
**Max power (DIN-NET):** 243 kW (326 HP) @ 2,000 RPM  
**(JIS Gross):** 251 kW (337 HP) @ 2,000 RPM  
**Max torque (DIN-NET):** 1,422 Nm (1,049 lb.ft) @ 1,200 - 1,500 RPM  
**(JIS Gross):** 1,472 Nm (1,086 lb.ft) @ 1,200 - 1,500 RPM  
**Induction system:** Electronically controlled variable nozzle turbocharger with air-to-air intercooler.  
**Fuel injection:** Direct injection high pressure common rail system.  
**Emission control system:** Two-stage electronically cooled EGR with exhaust Diesel Particulate Diffuser (DPD). ADR 80/03 (J-NLT05) compliant.

#### ENGINE DRIVEN PTO (PTO models only):

- Constant mesh. Rotates at 1.1 x engine speed.
- 440 Nm maximum output torque.
- Anti-clockwise rotation when viewed from rear of engine.

### CLUTCH

- Air assisted hydraulic control. Single plate 432 mm diameter.
- Total lining area: 1,923 cm<sup>2</sup>

### TRANSMISSION

#### Eaton RTO 11908LL

- 10 speed constant mesh.
- Gear ratios (: 1)

LL	L	1st	2nd	3rd	4th	5th
14.56	9.42	6.24	4.63	3.40	2.53	1.83
6th	7th	8th	RLL	RL	RH	
1.36	1.00	0.74	15.22	9.85	2.89	

### AXLES

#### Front: MERITOR

- FG941 reverse Elliot I-beam. 6,600 kg capacity.

#### Rear: MERITOR

- RT-40-145G tandem axle set. 18,100 kg capacity.
- Driver controlled inter-axle lock and cross locks on both axles.
- Drive ratio: 4.88

### SUSPENSION

#### Front:

- Single stage alloy steel taper leaf springs.
- Double acting hydraulic shock absorbers. Stabiliser bar.

#### Rear

- Taper leaf springs with Isuzu 6 rod and trunion location system.

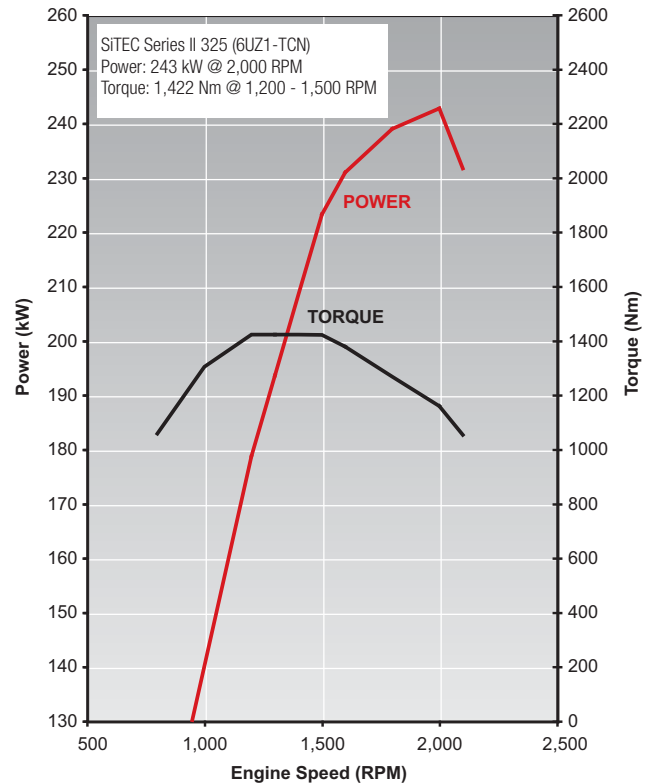

### BRAKES

- Meritor 'Q-Plus' dual circuit full air 'S-cam' front and rear drum brakes with auto slack adjusters.
- ABS.
- Front drum size: 419 x 127 mm
- Rear drum size: 419 x 178 mm
- Spring park brake acting on all rear wheels.
- Air controlled exhaust brake.
- Air dryer.

### STEERING

- Power assisted recirculating ball steering.
- Gear ratio: 22.4:1
- Turns lock to lock: 5.4
- Maximum angle: 45° (inside wheel) / 35° (outside wheel)

### WHEELS AND TYRES

- 22.5 x 8.25 ten stud ISO standard steel wheels.
- Steer axle: 295/80R22.5 152/148M Michelin XZE2 Tubeless
- Drive axles: 11R22.5 148/145L Michelin XDE2 Tubeless
- Maximum tyre rating:
  - Steer axle: 7,100 kg
  - Tandem drive axle set: 23,200 kg
- Spare wheel rim supplied with winch type carrier.

## CHASSIS FRAME

- Cold rivetted ladder frame. HT540A high tensile weldable steel sidemembers.
- Frame dimensions:
  - Side rail (mm): 285 x 85 x 7.0
  - Rear frame width (mm): 850

## FUEL TANK

- Frame mounted 200L aluminium fuel tank.
- Lockable fuel cap.

## ELECTRICAL SYSTEM

- 24 volt electrical system.
- 60 amp alternator.
- 24 Volt, 5.0 kW starter motor.
- 2 x 80D26L (630 CCA) batteries connected in series.

## Cabin Specifications and Appointments

### CAB EXTERIOR

- All steel construction with electro-hydraulic cab tilt. High tensile steel used for cab underframe.
- Full floating cab with coil spring suspension and hydraulic shock absorbers.
- Heavy duty non slip entry steps.
- 90° opening internally reinforced front doors.
- Water spray suppression guards and front mudflaps.
- Laminated windscreen with shade band.
- Two speed windscreen wipers, with intermittent wipe mode.
- Halogen multi-reflector headlamps incorporating turn signals and front foglamps. Additional door mounted side indicator lamps.
- Combination brake, turn, reverse and marker lamps, registration plate illumination lamps. Extended wiring harness. Reverse alarm.
- Roof-mounted clearance lamps.
- Heated and powered exterior main mirrors with flat glass and additional powered convex "spot" mirrors.
- Chrome grille.
- Body coloured steel air dam bumper.

### CAB INTERIOR

- Isri 6860 air suspension driver's seat with pneumatic lumbar support, height, rake and automatic weight adjustment.
- Front passenger adjustable bucket seat and front centre seat with folding seat back.
- 3-point lap sash seatbelts in all outboard seating positions. Driver seatbelt with pre-tensioner integrated with driver seat. Centre seat lap belts.
- ADR 42 compliant sleeper with mattress.
- Driver airbag.
- Door and roof pillar entry assist grips.
- Full interior trim, padded roof lining and vinyl floor covering. Overhead front storage compartments.
- Tilt/Telescopic adjustable steering column, soft feel urethane steering wheel.
- Central locking with remote keyless entry.
- Twin cup holders. 24V cigarette lighter. Dashboard hook.
- Front door mounted storage pockets and driver's side ashtray.

- Centre console box with storage tray.
- Front passenger glovebox.
- Fully integrated auto control air conditioning and heater/demister with 4-speed fan and outlets for windscreen, side windows, face and floor.
- Fluorescent type interior lamp with On/Door/Off switch.
- 2 DIN, two speaker radio/CD multimedia unit and module for Bluetooth/iPod input/SD card reader.
- DIN sized compartment for storage or for CB radio installation.

### DRIVER CONTROLS

- Key-operated engine start/stop and steering lock. Engine idle speed control.
- DPD regeneration.
- Inter-axle lock and cross lock engage switches.
- **Left side combination stalk:** Windscreen wipers, washers and exhaust brake.
- **Right side combination stalk:** Turn signals, headlamps, cruise control.

### INSTRUMENTATION

- Electronically driven speedometer and tachometer. Digital odometer with integrated dual tripmeter. Engine coolant temperature, fuel level and air pressure gauges.
- **Warning lamps:** Check engine, oil pressure, ABS, SRS airbag, alternator charge, service brakes, park brake, seat belt unfastened, low air pressure, low fuel level, cab lock.
- **Indicator lamps:** HSA Warm up system, high beam, DPD status, exhaust brake, turn signals, inter-axle lock, cruise control.
- **Multi-information display.** Shows service interval, instantaneous and average fuel consumption, DPD bar chart, hourmeter, voltmeter, time/day/date and includes 40-120 km/h adjustable vehicle speed warning.

### OPTIONS AND GENUINE ACCESSORIES

Include the following (extra cost, check with dealer for availability):

- Replacement module for Bluetooth/iPod input/SD card reader/satellite navigation (includes NAVTEQ mapping).
- Up to two reversing cameras.
- Cloth seat covers.

### Weights (kg)

Models	Ratings*		Loading Limit* (at ground)		Cab Chassis Mass#		
	GVM	GCM	Front	Rear	Front	Rear	Total
FXZ 1500 Medium	24,000	42,500	6,600	18,100	4,030	3,275	7,305
FXZ 1500 Medium PTO	24,000	42,500	6,600	18,100	4,135	3,290	7,425

\*Vehicle ratings and front/rear weight limits are subject to government regulatory requirements and weight distribution analysis. Consult your Isuzu dealer to select the correct vehicle for your specific application.  
# Cab chassis only as supplied and including 10 litres of fuel.

### Dimensions (mm)

Models	WB	OAL	FOH	ROH	EA	CE	RT	ORT	CH	FFA (unladen)	RFA (unladen)	RFH (unladen)	Turn Circle (m)
													KERB TO KERB
FXZ 1500 Medium / Medium PTO	4,330	7,790	1,480	1,980	3,650	5,750	1,840	2,445	3,020	920	1,095	1,140	15.1

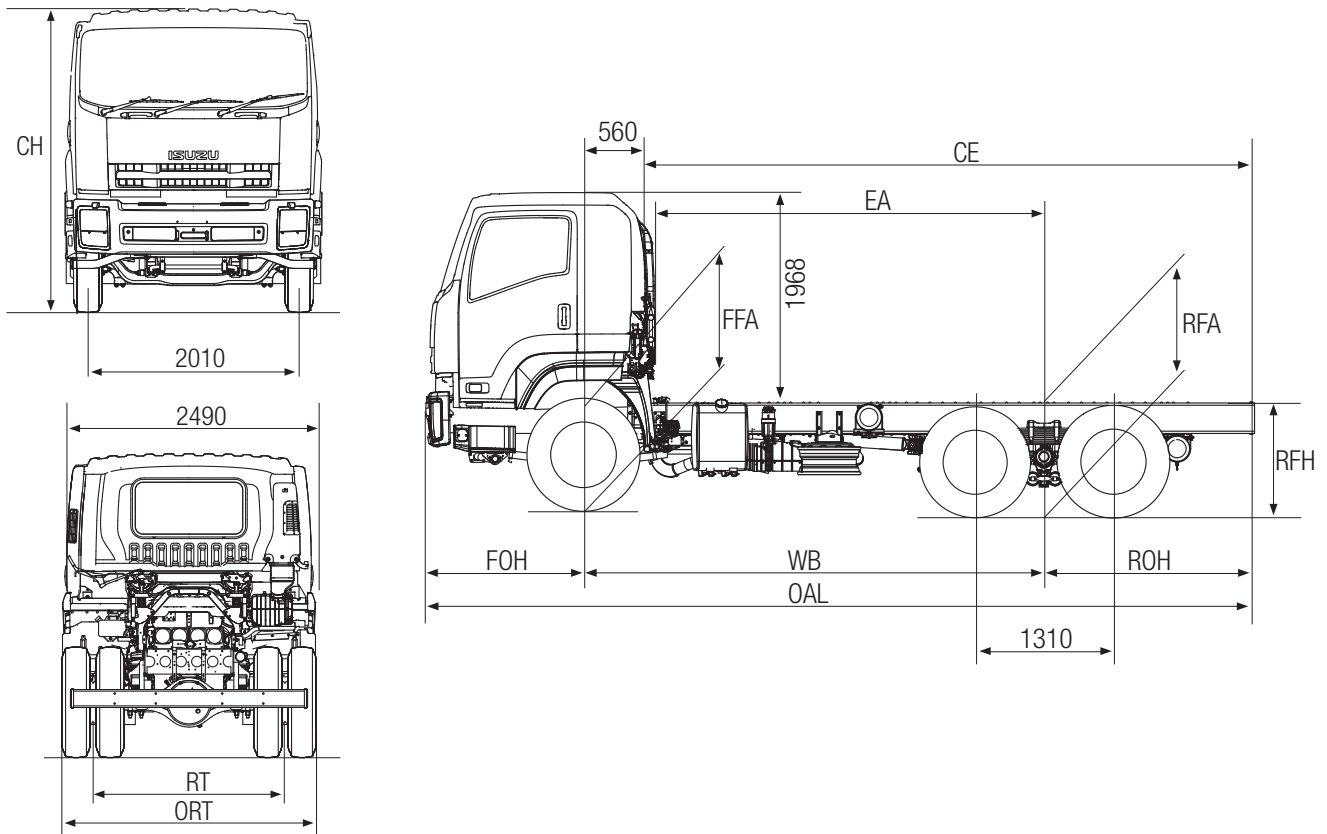

### Performance (calculated - typical paved road)

		Geared Speed* (top gear at peak power engine RPM)	Low Speed Gradeability (lowest forward gear assuming no wheel slip)	Engine Speed (top gear at 100 km/h)
FXZ 1500	At 24,000 kg GVM	107 km/h @ 2,000 RPM	74%	1,865 RPM

\* Maximum speed achievable depends on vehicle frontal area as well as other factors. Consult your Isuzu dealer for more detailed information. Vehicle is speed limited to 100 km/h.

### Isuzu Warranties

STANDARD <sup>1</sup>		
New Vehicle	3 years   250,000 km   4,000 hrs	
Cab Perforation Corrosion	3 years   Unlimited km	
EXTENDED <sup>2</sup>		
4 years   350,000 km	5 years   400,000 km	6 years   450,000 km

<sup>1</sup> Subject to the conditions outlined in the IAL New Vehicle Warranty, the Isuzu FXZ models carry a standard factory warranty which covers the owner: (i) for the entire vehicle, for the first 36 months or 250,000 km or 4,000 hrs (whichever comes first). (ii) against cab perforation corrosion, for 36 months and unlimited kilometres. <sup>2</sup> Extended Warranty as illustrated is available by purchase to cover the owner against the failure of original components, but may exclude some components and expendable items such as oil, filters, etc. Please consult with your Isuzu Dealer for full details obtained from a dedicated brochure available to customers.

ISUZU AUSTRALIA LIMITED ABN 97 006 962 572 ("IAL"). The information in this brochure was correct at time of printing, but all measurements, specifications and equipment are subject to change without notice. Some equipment may have been changed and/or is available at extra cost. IAL may make changes at any time without notice, in prices, colours, materials, equipment and models. IAL makes all reasonable attempts to ensure the availability of all vehicles and equipment. The information in this brochure is general in nature. Your Isuzu dealer can confirm all measurements, specifications and vehicle / equipment availability upon request.

November 2008. ARK0348