

# ISUZU NPR 250/300

## MEDIUM



### ENGINE ISUZU 4HF1

- Type:** 4 cylinder, four stroke, overhead camshaft, direct injection, diesel.
- Bore x Stroke:** 112 mm x 110 mm.
- Displacement:** 4334 cc.
- Compression Ratio:** 19.0 : 1.
- Output - Power:** 85 kW @ 3200 RPM (DIN Nett)
- Torque:** 285 Nm @ 1800 RPM (DIN Nett)

### CLUTCH

- Hydraulic control dry single plate with diaphragm spring.
- Asbestos free clutch plate 300 mm diameter. Total lining area 847 cm<sup>2</sup>.

### TRANSMISSION ISUZU MXA5R

- 5 speed overdrive, synchromesh with remote control short gear shift lever.
  - Gear ratios (: 1)
- |      |       |       |       |       |       |
|------|-------|-------|-------|-------|-------|
| 1st  | 2nd   | 3rd   | 4th   | 5th   | Rev   |
| .987 | 2.870 | 1.594 | 1.000 | 0.728 | 4.774 |
- Maximum geared speed 121 km/h.
  - Single piece propeller shaft, 82.6 mm diameter. Length: 1st section, 830 mm; 2nd section, 964 mm.

### REAR AXLE - CAPACITY 4000 KG

- Banjo type, fully floating, single reduction. Ratio 5.857: 1.
- Hypoid type ring gear, 292 mm diameter. Oil capacity 3 litres.

### BRAKES

- Hydraulic dual circuit, vacuum assisted, front two leading, rear dual two leading with automatic adjustment. Drum diameter front and rear 320 mm. Total swept area 3016 cm<sup>2</sup>.
- Asbestos free lining material. Width 75 mm.
- Mechanical park brake, internal expanding at rear of transmission. Lever beside driver's seat.
- Butterfly, vacuum controlled exhaust brake system. Activation switch on wiper/washer control stalk.
- Load sensing proportioning valve.

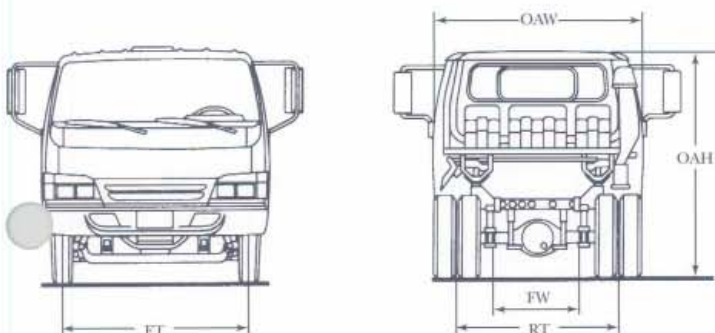

MODEL	WHEELBASE	GVM	GCM	ORDERING CODE
NPR 250/300 MED.	3365mm	4490/ 6200kg	6490/ 8200kg	8NS02-221

### KERB MASS (kg)\*

	Front	Rear	Total
NPR 250/300 MED.	1,415	775	2,190

\*Estimated mass of chassis cab with oil, water and full fuel tank. Excluding spare wheel and tools.

### DIMENSIONS (mm) \*

	NPR 250/300 MED.
BBC Bumper to Back of Cab	1610
CE Cab to End of frame	4345
CA Cab to Axle	2840
BOC Back of Cab to Air/Exhaust Clearance	200
BA Bumper to front Axle	1085
WB Wheelbase	3365
OAL Overall Length	5955
AF Rear Axle to end of Frame	1505
OAW Overall Width	1995
OAH Overall Height	2195
FW Frame Width	750
RT Rear Track	1485
FT Front Track	1665
Turning Circle *(Kerb to Kerb)	12.4
Nominal Max. Body Length *	4570

\*Except Turning Circle: metres. \*Subject to weight distribution

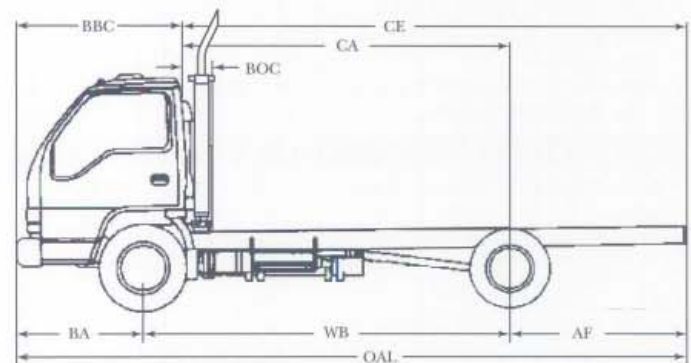

ISUZU GENERAL MOTORS AUSTRALIA LTD A.C.N. 200 962 WARRANTY: Subject to the conditions of the I-GM New Vehicle Warranty, every Isuzu N Series Truck carries a warranty which covers your vehicle for the first 24 months or 50,000 kms (whichever comes first). A 36 month or 100,000 kms (whichever comes first) power train warranty runs concurrently with the new vehicle warranty, as does a 56 months unlimited kilometre 120 component warranty. PLEASE NOTE: In the sales of I-GM it is one of our central product improvement, all specifications and equipment are subject to change without notice. The body illustrated is not standard equipment. No I-GM Dealer or other person is authorized or permitted to give or make any statement, insertion or undertaking in relation to the quality, performance, characteristics, descriptions or fitness for any purpose of any I-GM product or in connection with the supply of any I-GM product which is at variance with any written statement, insertion or undertaking or any of these set out or made by I-GM in its published sales literature, and the company accepts no liability for any such misstatements or omissions. I-GM has franchise dealers in many parts of Australia. For the sake of service, purchase the previous of service to the nearest I-GM retail vehicle accessory. Some parts or services facilities will be available or available at any specific location or at any particular time. A word about this specification sheet: We have tried to make it as comprehensive and factual as possible. However, since the time of printing some of the information may still find here may have been updated. Also, some of the equipment shown as described through this specification sheet may have been changed and/or is available or not available. And the right is reserved to make changes at any time without notice, in prices, colours, finishes, equipment and models. Your I-GM dealer has details and before accepting, you should ask him/her to bring you up to date.

# ISUZU

RELIABILITY IS EVERYTHING

## AIR CLEANER

- Cartridge type, 197 mm diameter paper element air cleaner, vertical intake stack with rain head and resonator.

## CHASSIS FRAME

- Ladder type, channel section, cold riveted.
- Side member dimensions 173 mm x 65 mm x 6 mm with 4.5 mm reinforcement.

## COOLING SYSTEM

- Eight blade plastic cooling fan, size 430 mm diameter, with thermatic clutch.
- Tube and corrugated fin pressure type radiator. Size (mm) 520 h x 471 w x 35 t. Frontal area 2447 cm<sup>2</sup>.

## ELECTRICAL SYSTEM

- Batteries - 2 x 12 Volt - 60 Amp/h, negative earth.
- Alternator - 24 Volt - 50 Amp.
- Starter motor - 24 Volt - 4.0 kW output.
- Rear stop and tail lamps with long leads for variable body mounting.
- Reverse warning beeper and lamps.

## EXHAUST SYSTEM

- Horizontal exhaust muffler with vertical exhaust stack.
- Vacuum operated, butterfly type exhaust brake.

## FRONT AXLE - CAPACITY 2700KG

- Reverse Elliot I-beam type. King pin diameter 30 mm with cylindrical roller thrust bearing.

## FRONT SUSPENSION - CAPACITY 2450KG

- Semi elliptical, alloy steel, tapered multi-leaf springs, with fully wrapped eye and metalastic bushes.
- **Length x Width x Thickness x No. leaves**  
1140 mm x 70 mm x 9 mm x 7
- Hydraulic, double acting, telescopic shock absorbers.

## FUEL SYSTEM

- In line plunger, Bosch 'A' type fuel injection pump with mechanical all speed governor. In line paper filter. Fuel/water sedimentor with warning lamp.
- Fuel tank capacity 115 litres.

## LUBRICATION

- Pressure feed lubrication with full flow paper element and partial flow sub filter. Plate type oil cooler in water jacket. Capacity 8.3 litres including filters.

## REAR SUSPENSION - CAPACITY 4000KG

- Semi elliptical, alloy steel, tapered multi leaf springs, with fully wrapped eye and metalastic bushes.
- **Length x Width x Thickness x No. leaves**  
Main: 1250 mm x 70 mm x 11 mm x 4  
70 mm x 10 mm x 1  
Aux: 850 mm x 70 mm x 9 mm x 4  
70 mm x 10 mm x 1
- Hydraulic, double acting, telescopic shock absorbers, bias mounted.

## STEERING

- Fully integral power assisted recirculating ball type. Gear ratio 20.9:1. Turns lock to lock 5.0.
- Steering lock.
- Gear driven vane type oil pump. Oil capacity 1.6 litres.
- Lube for life drag link.

## TOOLS

- Wheel changing tools including 5000 kg capacity hydraulic jack.
- Hand tools in kit bag.

## WHEELS AND TYRES

- 6.00 GS X 16 - 5 stud disc wheel, 16 mm stud size, 127 mm offset.
- 7.50R16LT - 8 ply Yokohama (highway tread) tyres.
- Number of tyres, 7 including spare.
- Winch type spare wheel carrier at rear of chassis.

## CAB EXTERIOR

- All steel cab, manual tilt to 45°.
- Aluminium non-slip entry steps.
- West Coast type rear view mirrors with clearance lamps. Convex surface on passenger side mirror.
- Access to fluid checks without tilting cab.
- Tinted, laminated windshield bonded in position, 2 speed wiper/4 jet washer, with intermittent mode.
- 4 rectangular semi-sealed beam headlamps.
- Combination turn signal and park lamps.
- Plastic wheel house liner.

## CAB INTERIOR

- Adjustable, reclining driver's bucket seat with lumbar support, 2 place passenger bench seat with folding back.
- Fire resistant cloth seat material.
- Retractable lap/sash seat belts on outboard seats, lap belt on inboard seat.
- Driver and passenger sun visors, padded roof lining.
- 90° opening, internally reinforced doors, double sealed.
- Tilt/telescopic adjustable steering column with soft feel urethane steering wheel.
- Easy access to fuses (behind glove compartment door).
- Easy entry grab handles on 'A' pillar.
- Windshield washer tank located under glove compartment.
- Heater demister with 4 speed fan.
- AM/FM Stereo radio cassette with digital clock, dash mounted.
- Engine access hatch in floor.
- Windshield header shelf.
- Cab roof air vent with fore and aft tilt adjustment.
- Optional air conditioning.

## INSTRUMENTATION

- Electronically driven speedometer with odometer and trip meter.
- Tachometer, electronically driven.
- Gauges for coolant temperature and fuel level.

## INDICATOR LAMPS

- Turn signals, parking brake on, high beam on, exhaust brake activated.

## WARNING LAMPS

- Battery charge, oil pressure, brake failure, fuel level, glow plug and water separator.

## CONTROLS

- Left side combination stalk control for exhaust brake, wipers and washer. Intermittent wipe, washer activated.
- Right side combination stalk control for turn signals and headlamps.
- Hazard switch.
- Key operation for engine stop/start with quick cold start aid.
- Three way switch for interior lamp activated by driver and passenger doors.
- Fast engine idle control.

# NPR 250/300

MEDIUM

**ISUZU**  
RELIABILITY IS EVERYTHING