



# Isuzu TLD 24/44



## Chassis/cab.

	<i>TLD 24</i>	<i>TLD44</i>
STD GVM	4200kg	4800kg
Tyres	7.50 x 15 - 10ply	7.00 x 15 - 8ply

### Engine

Model: ISUZU 4BA1 Diesel Engine  
 Type: Four cycle, Overhead valve, in line.  
 No. of cylinders: Four.  
 Bore and Stroke: 98x92mm.  
 Displacement: 2775cm<sup>3</sup>.  
 Max net power: 52kW @ 4000 rpm.  
 Max net torque: 162Nm @ 2200 rpm.  
 Compression ratio: 19.0:1.  
 RAC rating: 23.8.

### Air Cleaner

Type: Wet paper 150mm diameter located on frame side.

### Axle, front

Capacity: 1800kg.  
 Type: Reverse eliott, I-beam.

### Axle, rear

Capacity: *TLD 24* - 3000kg.  
*TLD44* - 3500kg.  
 Type: Banjo fully floating, Hypoid gear 244mm diameter.  
 Ratio: *TLD 24* - 5.857:1.  
*TLD 44* - 6.142:1.

### Brakes, Service

Type: Dual circuit hydraulic, vacuum assisted.  
 Total lining area: *TLD 24* - 1288cm<sup>2</sup>.  
*TLD44* - 1752cm<sup>2</sup>.

### Brake, Parking

Type: Mechanical, expanding at rear of transmission.

### Clutch

Type: Dry single plate with diaphragm springs, 240mm diameter.

### Electrical System

Battery: 12 volt/120 amp/hr. negative to earth.  
 Alternator: 12 volt/40 amp.  
 Starter: 12 volt/2.2kW.

### Frame

Type: Ladder type channel section  
 Frame width: *TLD 24* - Front: 730mm, Rear 800mm.  
*TLD44* - Front: 730mm, Rear 680mm.  
 Side member dimensions: (length x width x thickness)  
*TLD 24* - 170 x 50 x 4.5mm.  
*TLD44* - 170 x 65 x 4.5mm.  
 Combined section modules (x10<sup>3</sup>mm<sup>3</sup>)  
*TLD 24* - 110.  
*TLD44* - 130.

### Suspension Front

*TLD 24* Semi-elliptical alloy steel leaf springs.  
 Capacity: 1235kg each spring.  
 Size: (length x width x thickness - number of leaves)  
 1140 x 60 x 7mm - 9.  
 Hydraulic double action telescopic shock absorbers.

### *TLD 24*

Semi-elliptical alloy steel leaf springs.  
 Capacity: 1255kg each spring.  
 Size: (length x width x thickness - number of leaves)  
 1140 x 60 x 8mm - 7.  
 Hydraulic double acting telescopic shock absorbers.

### Engine Lubrication

Pressure feed with full flow paper element oil filter.  
 Capacity: 8.0 litres with filter.

### Engine Cooling

Fan Type: 6 blade plastic, 395 mm diameter.  
 Radiator: 490 x 471 x 53mm tube and corrugated fin.  
 Frontal area: 0.231m<sup>2</sup>.

### Fuel System

Injection pump: Bosch 'A' in line with mechanical and pneumatic combined governor.  
 Fuel Tank Capacity: *TLD 24* - 66 litres.  
*TLD44* - 90 litres.

### Suspension Rear

*TLD 24* Semi-elliptical alloy steel leaf springs.  
 Capacity: 1365kg each spring.  
 Size: (length x width x thickness - number of leaves)  
 1200 x 70 x 8 mm - No's 1-2.  
 9 mm - No's 3-6.

Hydraulic double acting telescopic shock absorbers.

*TLD 44* Semi-elliptical, alloy steel leaf spring.  
 Capacity: 2630kg each spring.  
 Size: (length x width x thickness - number of leaves)  
 Main: 1300 x 70 x 9mm - 8.  
 Auxiliary: 850 x 70 x 7mm - 3.  
 Hydraulic double acting telescopic shock absorbers.

### Steering

Type: Recirculating ball.  
 Gear ratio: 27:1. Steering wheel diameter: 420mm.  
 Number of turns lock to lock: 5.3.

### Turning Circle

Wall to wall: 11.8 metres.

### Transmission

Model: ISUZU MSB5S.  
 Type: 5 speed overdrive. Synchromesh on all forward gears.  
 Floor mounted gear shift.  
 Ratios: (to 1).

1st	2nd	3rd	4th	5th	Reverse
5.037	2.683	1.591	1.000	0.782	4.802

### Wheels and Tyres

Wheel size: *TLD 24* - 5.5 F x 15 6 stud.  
*TLD 44* - 5.5 F x 15 5 stud.  
 Tyres: *TLD 24* - 7.50 x 15 - 10 ply (single rear wheels and tyres).  
*TLD 44* - 7.00 x 15 - 8 ply (dual rear wheels and tyres).  
 Spare wheel and tyre are standard.

### Standard Equipment

**Exterior:** All steel fixed cab. Laminated windshield. Passenger and driver side exterior mirrors. Two speed windshield wipers, windshield washer. Electric horn. Dual sealed beam headlamps. Hydraulic jack and wheel wrench.

**Interior:** Vents - side and floor. Inside rear view mirror. High back bucket driver's seat. 2 seater passengers' seat. Driver and outboard passenger seat belts and assist grips. Sunvisors. Ashtray. Vinyl floor mats. Two speed heater/demister. AM Radio. Hazard warning lights. Engine stop lever.

**Instruments:** Speedometer and odometer. Gauges for fuel level and engine temperature. Warning lights for low oil pressure generator, park brake and headlamp high beam. Combination switch for headlamp dimmer, turn signal, passing signal, windshield wiper and washer.





# Isuzu TLD 24/44



## DIMENSIONS/CHASSIS WEIGHTS

LENGTHS (mm)		TLD 24	TLD 44
Wheelbase WB	WB	2470	2465
Front overhang FOH	FOH	1010	1010
Rear Overhang ROH	ROH	1105	1130
Bumper to back of cab	BBC	1475	1475
*Cab to axle	CA	2005	2000
*Cab to end of frame	CE	3110	3130
Overall length	OAL	4585	4605

\*CA and CE dimensions are effectively reduced by 125mm with fitment of vertical exhaust pipe and protector for TLD 44 only.

WIDTHS (mm)		TLD 24	TLD 44
Frame width (rear)	FW	800	680
Front track	FT	1395	1395
Rear track	RT	1395	1425
Outside width - rear tyres	OW RT	1605	1850
Overall width	OAW	1690	1690

HEIGHTS (mm) (approx.)		TLD 24	TLD 44
Overall height	OAH	1985	1985
Front axle clearance	B	175	175
Frame height	FH	705	715

TURNING CIRCLE (m)		TLD 24	TLD 44
Wall to wall		11.8	11.8

### GMH 12/20 Warranty

Every Isuzu cab/chassis is covered by the GMH warranty which covers your vehicle for the first 12 months or 20,000 kilometres, whichever occurs first.

PLEASE NOTE: As the policy of General Motors-Holden's is one of continual product improvement, all specifications and equipment are subject to change without notice. Bodies illustrated are not standard.

No GMH Dealer or other person is authorised or permitted to give or make any statement assertion or undertaking in relation to the quality performance characteristics descriptions or fitness for any purpose of any GMH product or in connection with the supply of any GMH product, which is at variance with any written statement assertion or undertaking on any of these subjects given or made by General Motors-Holden's Limited or General Motors-Holden's Sales Pty. Limited in its published sales literature, and neither company accepts any liability for any such unauthorised action.

General Motors-Holden's Limited and General Motors-Holden's Sales Pty. Ltd. have franchised dealers in many parts of Australia for the sale of service parts and the provision of service of owners of GMH's products. Every endeavour is made to ensure that such dealers carry adequate stocks of service parts, and are equipped to provide satisfactory service, but neither General Motors-Holden's Limited nor General Motors-Holden's Sales Pty. Ltd. makes any promise, other than that contained in the New Vehicle Warranty given by General Motors-Holden's Sales Pty. Ltd., that such parts or service facilities will be available, or available at any specific location or any particular time.

General Motors-Holden's Sales Pty. Ltd.

*Tray body 1/2 WB + C.A. (ROH must not exceed 60% of WB)*

Vertical exhaust pipe and protector applicable to TLD 44 only.

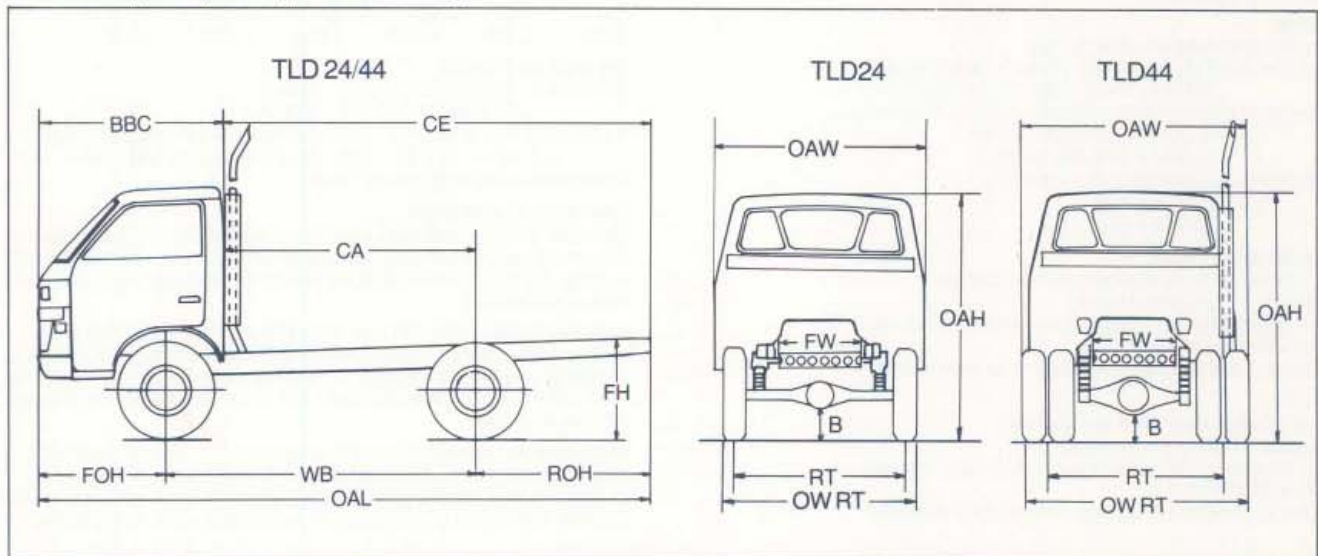

GROSS VEHICLE AND GROSS COMBINATION MASS RATING (kg)				ESTIMATED KERB MASS, CHASSIS AND CAB: with oil, water and full fuel tank (kg).			
Model	GVM	GCM	Tyres	Model	Front	Rear	Total
TLD 24	4200	6300	7.50 x 15 - 10 ply	TLD 24	1090	485	1575
TLD 44	4800	6300	7.00 x 15 - 8 ply	TLD 44	1140	575	1715