

ISUZU FRR 500/550

CREW



ENGINE ISUZU 6HH1-N

Type: 6 cylinder, overhead camshaft, 4 stroke, direct injection, diesel.
Bore x Stroke: 115 mm x 132 mm.
Displacement: 8226 cc.
Compression Ratio: 18.5 : 1.
Output - Power: 129 kW @ 2800 RPM. (ISO 1585)
Torque: 490 Nm @ 1700 RPM. (ISO 1585)

CLUTCH

- Hydraulic control dry single plate. 325 mm (13") diameter.
- Asbestos free lining material. Total lining area (both sides) 966 cm².

TRANSMISSION ISUZU MBJ5J (500 CREW)

- 5 speed direct drive, constant mesh with synchromesh on gears 2-5. Oil capacity 4.4 litres.
 - Gear ratios (: 1)
- | | | | | | |
|-------|-------|-------|-------|-------|-------|
| 1st | 2nd | 3rd | 4th | 5th | Rev |
| 6.378 | 3.627 | 2.307 | 1.452 | 1.000 | 6.595 |
- Maximum geared speed 108 km/h.
 • 2 piece propeller shaft, 90 mm diameter.

TRANSMISSION ISUZU MBJ6T (550 CREW)

- 6 speed overdrive, constant mesh with synchromesh on gears 2-6. Oil capacity 5.3 litres.
 - Gear ratios (: 1)
- | | | | | | | |
|-------|-------|-------|-------|-------|-------|-------|
| 1st | 2nd | 3rd | 4th | 5th | 6th | Rev |
| 6.378 | 3.627 | 2.307 | 1.452 | 1.000 | 0.787 | 6.595 |
- Maximum geared speed 116 km/h.
 • 2 piece propeller shaft, 90 mm diameter.

REAR AXLE ISUZU R077 CAPACITY 7700 KG

- Banjo type, fully floating, single reduction. Ratio (500 Crew) 4.333 : 1, (550 Crew) 5.125 : 1.
- Hypoid type ring gear. 343 mm diameter. Oil capacity 5.5 litres.

BRAKES

- Air over hydraulic, dual circuit, front two leading, rear dual two leading. Drum diameter front and rear 320 mm. Total swept area 5127 cm².
- Air dryer.
- Asbestos free lining material.
- Spring park brake acting on rear wheels.

MODEL	WHEELBASE	GVM	GCM	ORDERING CODE
FRR 500 CREW	4250mm	10,000kg	16000kg	8FC03-261
FRR 550 CREW	4850mm	10000kg	16000kg	8FF03-261

KERB MASS (kg)*

	Front	Rear	Total
FRR 500 CREW	2,270	1,030	3,300
FRR 550 CREW	2,315	1,055	3,370

*Estimated mass of chassis cab with oil, water and fuel tank containing 10 litres of fuel. Excluding spare wheel and tools.

DIMENSIONS (mm) *

	FRR 500 CREW	FRR 550 CREW
Wheelbase (WB)	4,250	4,850
Overall Length (OAL)	7,220	8,170
Rear Overhang (ROH)	1,785	2,135
Cab To Axle (CA)	2,745	3,345
Cab To End Of Frame (CE)	4,530	5,480
Front Frame Height, Unladen (FFH)	795	785
Front Frame Height, Laden (FFL)	770	761
Rear Frame Height, Unladen (RFH)	875	900
Rear Frame Height, Laden (RFL)	809	835
Turning Circle (Kerb To Kerb)	13.4m	14.9m
Nominal Max. Body Length*	4,890	5,850

*Except Turning Circle: metres. *Subject to weight distribution

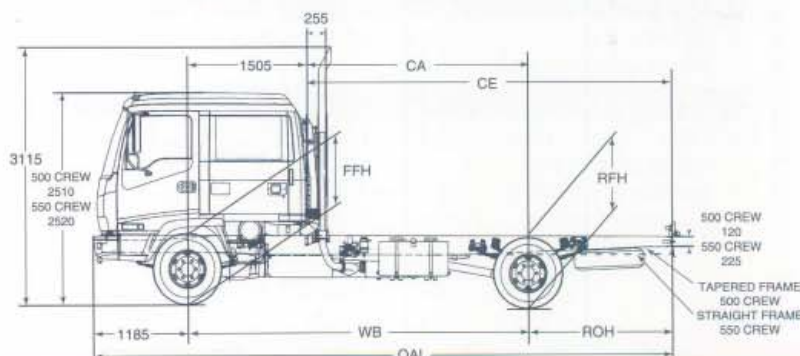
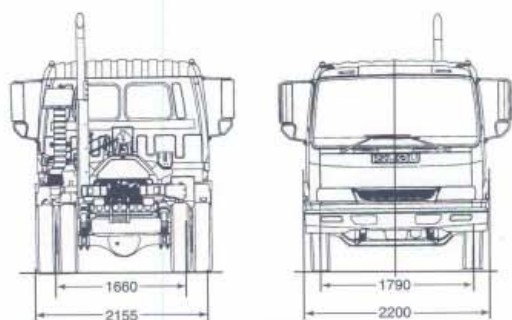

ISUZU GENERAL MOTORS AUSTRALIA LTD A.C.N. 006 982 372 21-100-000 WARRANTY. Subject to the conditions of the IGM New Vehicle Warranty, every Isuzu Truck carries a warranty which covers your vehicle for the first 24 months or 100,000 kms whichever comes first. A 90,000 kms (whichever comes first) power train warranty runs concurrently with the new vehicle warranty, in does so in respect of unlimited kilometres only over those years. PLEASE NOTE: as the policy of IGM is one of continual product improvement, all specifications and equipment are subject to change without notice. See back illustration in new standard equipment. No IGM dealer or other person is authorised or permitted to give or make any statement, assertion or undertaking in relation to the quality, performance, characteristics, descriptions or IGM or its published sales literature, and the company accepts no liability for any such statement or assertion. IGM has authorised dealers in some parts of Australia, for the sale of service, parts and the provision of advice to the owners of IGM products. Every endeavour is made to ensure that such dealers carry adequate stocks of service parts and are equipped to provide satisfactory service. No makes or prices, other than that contained in the IGM new vehicle warranty, that such parts or service facilities are available or available at any specific location or at any particular time. A model does not mean its name alone. We have endeavoured to make it as comprehensive and factual as possible. However, since the time of printing some of the information you will find here may have been updated. Also, some of the equipment shown or described through this specification may have been changed and is available in extra cost. And the right is reserved to make changes at any time without notice, in prices, colours, materials, equipment and models. Your IGM dealer has details and before ordering, you should not forget to bring your up to date.

ISUZU

RELIABILITY IS EVERYTHING

AIR CLEANER

- Donaldson 11" two stage with vertical air intake stack and rain head.

CHASSIS FRAME

- Parallel rail, ladder type channel section, cold riveted.
- Straight frame for easy body mounting. Frame width 840 mm.
- Side member dimensions 225 mm x 70 mm x 6 mm.
- Frame reinforcement angle section 203 mm x 64 mm x 4.5 mm at back of cab.
- Material HT540A high tensile, weldable steel.

COOLING SYSTEM

- 6 blade plastic cooling fan 500 mm diameter with thermatic fan clutch.
- Corrugated fin radiator with fan shroud. Frontal area 3820 cm². Coolant capacity 23.3 litres.

ELECTRICAL SYSTEM

- Batteries - 2 x 12 volt / 65 amp/h, negative earth.
- Alternator - 24 volt / 40 amp.
- Starter motor - 24 volt / 4.5 kW.
- Rear stop and tail lamps and licence plate lamp with long leads for variable body mounting.

EXHAUST SYSTEM

- Horizontal exhaust muffler with vertical exhaust stack.
- Exhaust brake, air controlled.

FRONT AXLE ISUZU F036 CAPACITY 3600 KG

- Reverse Elliot I-beam type. King pin diameter 35 mm with cylindrical roller thrust bearing.

FRONT SUSPENSION

- Semi-elliptical, alloy steel tapered multi-leaf springs. Fully wrapped eye with greaseable shackles.
- **Length x Width x Thickness x No. leaves**
1200 mm x 70 mm x 10 mm x 8
- Hydraulic, double acting, telescopic shock absorbers.

FUEL SYSTEM

- In line plunger, Bosch 'AD' type fuel injection pump with mechanical all speed governor. In line filter; see through water separator with drain cock. Single fuel tank, capacity 180 litres.

LUBRICATION SYSTEM

- Pressure feed lubrication with combination full flow and partial flow by-pass filter. Plate type oil cooler in water jacket. Oil capacity 13.5 litres including filter.

REAR SUSPENSION

- Semi-elliptical, alloy steel tapered multi-leaf springs. Fully wrapped eye with greaseable shackles.
- **Length x Width x Thickness x No. leaves**
Main: 1300 mm x 70 mm x 11 mm x 8
Aux: 850 mm x 70 mm x 10 mm x 3
850 mm x 70 mm x 11 mm x 4

STEERING

- Fully integral, power assisted, recirculating ball type.
- Gear ratio 16.1 ~ 18.8 : 1. Turns lock to lock 4.1.
- Gear driven vane type oil pump. Oil capacity 1.5 litres.

TOOLS

- Lockable tool box with 7000 kg capacity jack and wheel changing tools, tool kit.

WHEELS AND TYRES

- 6.00 x 17.5, 6 stud disc wheels, 225/90R17.5-14 ply tubeless tyres front and rear.
- Number of wheels and tyres 7, including spare. Winch type spare wheel carrier.

CAB EXTERIOR

- All steel, power tilt 4 door cab with welded strengthening ribs and side door impact beams.
- Cation electrodeposition primer.
- Bumper bar with step holes and footplate.
- Halogen headlamps, hinged for easy bulb replacement. Park lamps and cab clearance lamps.
- Turn signal lamps in front bumper and doors.
- 2 speed wiper/washer with variable intermittent mode. Triple washer jets mounted on wiper arms.
- Tinted, laminated windshield; tinted, toughened side and rear glass.
- West Coast type rear view mirrors. Convex mirror surface on passenger side.
- Alloy non-slip cab front entry steps. Steel rear entry steps.
- Lift up front access panel for clutch and windscreen washer fluids, cab air filter screen. Engine and brake fluid check points at rear of cab.

CAB INTERIOR

- Driver's seat with mechanical suspension and 3 way lumbar support. Adjustment for seat back recline, seat slide and weight control.
- Outboard reclining passenger seat with under-seat storage drawer. Folding centre seat back with lockable compartment and tray.
- Rear 4 person bench seat.
- Vinyl seat material and heavy duty vinyl floor mat, formed roof lining. Overhead storage lockers. Driver and passenger sun visors.
- All outboard seating positions have lap/sash seat belts with emergency locking retractors. All inner seating positions have lap seat belts.
- Pull out drinks holder in centre fascia, cigarette lighter with ash trays in all doors.
- Tilt/telescopic adjustable steering column, soft feel urethane steering wheel.
- Easy entry grab handles on 'A' & 'B' pillars (front doors) and 'B' and 'C' pillars (rear doors).
- Heater demister with 4 speed fan, 4 outlet vents to screen, 5 fascia outlets, 5 foot outlets, demister ducts to door glass.
- AM/FM radio cassette with digital clock, dash mounted.
- DIN standard aperture in dash for CB radio.
- Park brake activation lever at left side of driver's seat.
- Rear vision mirror.
- Front passenger side assist grip. Full cab width grab rail for rear passengers.
- Driver's left foot rest.
- Business card clip.
- Elastic mesh pocket on driver's door.

INSTRUMENTATION

- Speedometer, odometer, trip meter and tachometer.
- Gauges for coolant temperature, fuel level and brake air pressure.

INDICATOR LAMPS

- Turn signals, parking brake on, high beam on, exhaust brake engaged.
- Reversing lamp and beeper.

WARNING LAMPS

- With warning bulb check switch.
- Battery charge, oil pressure, low air pressure, brake system, stop and tail light failure.

CONTROLS

- Left side combination stalk switch for exhaust brake, windscreen wipers and washer, hazard lamps.
- Right side combination stalk switch for headlamps, high beam and turn signals.
- Engine idle speed adjust control.
- Key operation for engine start and stop, external engine crank switch for service when cab is tilted.
- 2 interior lamps, each with 3 way switch, activated by either front door.
- 24 volt-2 pin accessory plug in centre console.

FRR 500/550

CREW

ISUZU

RELIABILITY IS EVERYTHING